



Custom Built in America. For Today. For the Future.

- *20, 25 and 30 ton capacity*
- *Multiple boom configurations*
- *Tier III Rated Cummins engine*
- *Four steering modes with auto-alignment*
- *Highly visible and ergonomically engineered two door cab with joystick controls*
- *Pick and carry capabilities*
- *Integrated safety features*
- *Many options available*



SERIES GD4430 Rough Terrain Crane



FEATURES

- 3 Section 77' Synchronized Boom
- Optional 4 Section Boom for Shorter Overall Length
- Self Lubricating Boom Slider Pads
- Two Speed Planetary Grooved Drum Hoist - with negative draft flange
- Auxiliary Hoist Option
- Hoist Drum Rotation Indicator
- High Visibility Cab – with multi position seat, in dash display, main wiper and upper wiper
- Electronic Joystick Controls
- Continuous 360 Degree Rotation
- Optional Rated Capacity Indicator – with digital display, CANbus system interface and overload shutdown
- Radio Anti Two Block System
- Rugged, Weatherproof Automotive Style Electrical System
- Design meets ANSI B30.5 Recommendations
- Heavy Duty Steel Fenders – integrated with the fuel and hydraulic tanks
- Electronically Controlled Powershift – six (6) forward speeds and six (6) reverse speeds
- Four Steering Modes with Auto-alignment
- Auto Centering Axles – rear have oscillation
- Hydraulic Disc Brakes (4)
- Planetary Swing Drive
- Swing Brake
- 24 Volt System
- Cantilever Style Outriggers
- Operators Manual and Parts Manual Included

General Sp

ENGINE

Cummins QSB 4.5 diesel engine, turbocharged, 4 cylinder water cooled 160 HP @2500 RPM (or Optional QSB 6.7 160 HP 6 cylinder). Electronic sensors and controls to reduce service issues and provide easy maintenance. Cummins 2 year, 2000 hour standard engine warranty.

Engine accessories:

Dry type air cleaner, with restriction indicator.

- Grid block heater.
- Engine block heater.

POWERTRAIN:

Electronically controlled powershift with six (6) forward speeds and six (6) reverse speeds. Torque converter.

- 3 forward speeds, high range.
 - 3 forward speeds, low range
 - Rear axle disconnect
- Maximum top travel speed of 25-MPH.*

AXLES:

Front: Rigid, front planetary type steer axle.

Rear: Oscillating rear planetary steer axle.

Both offer Auto Centering feature.

SUSPENSION:

Oscillation with hydraulic lockout device.

BRAKES:

Fully hydraulic disc type brakes on all four wheel locations.

Emergency braking and parking brake system is spring applied and hydraulic release mounted on the front axle input shaft.

TIRES:

Manufacturers standard of sufficient load capacity for a fully loaded crane to perform pick and carry operation. All optional foam-filled tires are matching and of premium grade. Spare tire mounted on rim is optional.

STEERING:

Hydraulic four wheel power steering with tilt steering column.

Hydraulic type steering with four (4) steering modes.

- 2 wheel front
- 2 wheel rear
- 4 wheel coordinated
- 4 wheel crab

Synchronized auto centering is standard.

ELECTRICAL:

24 volt charging system with weather proof electrical harnesses.

Alternator: 70 ampere minimum rated capacity

Batteries: Two (2) batteries.

FUEL TANK:

Tank capacity is 75 gallons. Optional 110 gallon capacity.

CARRIER:

High tensile steel with all welded triple-box beam construction fully reinforced. Fully machined turn-table mounting plate and integrally welded outrigger mounts. Decking has skid resistant surfaces including tool storage compartment. Access steps and grab handles are provided on left and right sides as well as front and rear corners. High-tensile steel design that produces high strength frame that reduces bending and weight.

OPERATORS CAB:

Fully enclosed one (1) person high visibility pressurized cab mounted on the front center of the carrier. All steel construction and has two hinged entry doors with tinted safety glass windows and shatter resistant windshield and roof glass.

- Air conditioning, automotive dash style
- Two each lockable exit doors (right and left side with pneumatic spring design)
- Sliding windows in doors and rear
- Mirrors
- Fire extinguisher
- Adjustable sun visor
- Windshield wiper
- Heater and defroster - 12000 btu hot water
- Eleven way adjustable, cloth cushioned seat with seat belt.

ELECTRONIC INSTRUMENT PANEL:

- Fuel level
- Tachometer
- Speedometer
- 6.5" LCD CANbus display
- Engine oil pressure
- Hydraulic oil pressure, temp and level
- Engine water temperature and level
- Torque converter oil temperature

Additional Equipment:

- Factory installed turn signals
- Back up alarm, steam cleanable, "ECCO"

HYDRAULIC SYSTEM:

- Boom telescope – 7" bore, 6" rod and 278.5" stroke.
- Boom hoist – 10" bore, 8" rod and 59" stroke.
- Boom swing – 2.96 cubic inch motor.
- Winching – 4.88 cubic inch motor.
- Outriggers – 8" bore, 4" rod and 20.5" stroke.

PUMPS:

Three (3) variable piston pumps for all crane functions.

CYLINDERS:

Double acting and of adequate size and length for all service functions.

HYDRAULIC RESERVOIR:

110 gallon minimum capacity reservoir with oil level and temperature indicator. Tank is constructed of steel and has internal baffles and diffuser. Filtration is 10-micron return filter with bypass protection and is located on the exterior of the hydraulic tank.

[Class 22/18/13E ISO4406-1999]

HYDRAULIC LINES:

All hydraulic lines are min 4:1 design factor and have provisions to prevent chaffing during operation. All fittings are O-Ring face seal type.

BOOM:

Three (3) section boom (up to 77' in length) of four sided box type construction. Consists of one (1) double acting telescopic cylinder. The cylinder is equipped with integral holding valves. Accessible wear pads for both vertical and horizontal forces support boom sections. Made of formed and welded high-tensile steel plate for maximum strength and weight ratio. Contact factory for boom options.



Specifications

UPPER STRUCTURE:

All welded design made from high alloy steel plate. Bolt on cast counterweight – 9000 lbs.

BOOM HEAD:

Welded to the inner boom section with a minimum of five (5) sheaves mounted on greaseless bushings. Auxiliary lifting sheave mounted on the main boom for single line work.

JIB (OPTIONAL):

20' swing-away side-stowed jib with super small jib head.

TURNTABLE:

Upper structure is mounted on an anti-friction bearing of the shear ball design. Single row, ball type with external teeth and is bolted to the revolving upper structure and bolted to the carrier frame.

BOOM SWING AND BRAKE SYSTEM:

Boom swing is 360 continuous and is hydraulically driven through planetary reduction type gears. Maximum swing speed (unloaded) is 3 R.P.M. Swing brake is heavy duty multiple disk actuated automatically from the operators cab. Two (2) position swing lock for pick and carry as well as travel modes.

MAIN HOIST:

Lebus grooved drum driven by a 2 speed hydraulic axial piston motor through a winch speed reducer for power load lowering and raising. Equipped with a counterbalance and wet disk brake system. Includes a drum rotation indicator.

WIRE ROPE:

Has three (3) complete wraps of cable on the drum at maximum boom extension and elevation with line at maximum parting and the hook block at ground level. Cable is 5/8" x 433 feet minimum. Maximum permissible load is 10,000 pounds with a minimum line speed of 385-FPM.

LOAD BLOCK:

Rating exceeds the cranes gross lift capacity and is equipped with a safety latch and is permanently marked with the maximum capacity. A three (3) sheave hook block and swivel hook with safety latch is provided.

OPTIONAL AUXILIARY HOIST:

Lebus grooved drum driven by a 2 speed hydraulic axial piston motor through a winch speed reducer for power load lowering and raising. Equipped with an automatic brake and counterbalance valve. Auxiliary hoist is controlled independently of the main hoist.

WIRE ROPE:

Three (3) complete wraps of cable on the auxiliary drum at maximum boom extension and elevation with the hook block at ground level.

OPTIONAL 7.5 TON OVER HAUL BALL:

Furnished with a down-haul weight of sufficient size and weight to keep the cable tightly wrapped on the auxiliary winch drum. Hook is equipped with a safety latch.

ANTI TWO BLOCK DEVICE:

Unit has a pendant type wireless warning device with audio alarm, warning light and function kickout.

CONTROLS:

Hand Controls are electronic joystick controlled type. All levers and pedals will be positioned for optimum efficiency.

Hand operated controls include the following:

- Swing
- Main winch
- Auxiliary winch
- Throttle lock
- Boom hoist
- High and low winch speed control
- Swing Brake
- Boom telescope
- Horn

Foot controls include:

- Accelerator
- Service brakes

Control switches include the following:

- Lights
- Ignition
- Engine stop
- Parking brake
- Steering modes
- Windshield wipers
- A.C./Heater/Defroster
- Outriggers

Permanently engraved labels, indicating control function and direction are furnished.

MULTI POSITION OUTRIGGERS:

Cantilever style outriggers are standard.

LIGHTING:**The following lights are furnished and installed:**

Two (2) brake/turn taillights.
Two (2) sealed beam headlights with turn signals.
Optional four (4) worklights.
Optional perimeter lighting.
Optional strobe lights.

WARRANTY:

1 year and 1500 hours standard warranty.

All specifications are subject to change.

LSI SYSTEM

The Standard System currently included is a load indicator system; this is a wireless system that has only audible alarm and function kick-out for A2B. This is standard equipment and is required by ASME B30.5 crane standard. It indicates load, boom length, boom angle, and two block status. The optional LSI Rated Capacity Indicator Option gives you an automatic shut down safety feature, and additional LSI graphical display on the dashboard. This system prevents the operator from lifting an un-safe load as long as the operator does not bypass the system in any way (ie removing the load cell from the hook or pressing the bypass switch). Be advised that the load cells and A2B switches should not be used during duty cycle work (ie threading rail or other rapid swinging and lowering operation) and should be stored on the machine.

OPTIONS

- Recovery Winch
- Side Handrails
- Front Windshield Protection Screening
- All Windows Anti-Vandal Protection Screening
- Rear View Wide Angle Camera(s) With Color Monitor in Dash
- Hydraulic Tool Ports and Hose Reel
- Pintle Hitch – Rear
- Boom Tip Fairlead
- Anti-Vandal Kit for Locks and Caps
- Install Customer Accessories, Radios and Sirens
- Custom Fleet Colors
- Work Lights
- Perimeter Night Lighting
- Extra Mirrors to View Outriggers
- Outrigger Travel Latches
- Open Door Latches
- Optional Heated Seat

**CD4420
20 TON CAPACITY**

Machine weight 52,500 lbs. (3 section boom)
Machine weight 56,000 lbs. (4 section boom)

**CD4430
30 TON CAPACITY**

Machine weight 54,000 lbs. (3 section boom)
Machine weight 55,500 lbs. (4 section boom)



CD4420 Lc

LIFTING CAPACITIES - POUNDS 3 SECTION (31' - 75' BOOM)

On OUTRIGGERS

LOAD RADIUS (ft)	BOOM LENGTH (ft)																	
	31			40			50			60			70			75		
	BOOM ANGLE (deg)	OVER FRONT (lb)	360° (lb)	BOOM ANGLE (deg)	OVER FRONT (lb)	360° (lb)	BOOM ANGLE (deg)	OVER FRONT (lb)	360° (lb)	BOOM ANGLE (deg)	OVER FRONT (lb)	360° (lb)	BOOM ANGLE (deg)	OVER FRONT (lb)	360° (lb)	BOOM ANGLE (deg)	OVER FRONT (lb)	360° (lb)
10	61	40000	40000	68	40000	40000												
12	57	33300	33300	65	33300	33300	70	33000	33000									
15	50	26600	26600	60	26600	26600	66	26600	26600	71	26600	26600						
20	36	20000	20000	51	20000	20000	60	20000	20000	65	20000	20000	69	20000	20000			
25	15	16000	16000	41	16000	16000	53	16000	16000	60	16000	16000	65	16000	16000	66	16000	16000
30				29	13300	13300	46	13300	13300	54	13300	13300	60	13300	13300	62	13300	13300
35				0	11400	10600	37	11400	10600	48	11400	10600	55	11400	10600	58	11400	10600
40							26	10000	8500	41	10000	8500	50	10000	8500	53	10000	8500
45							0	8500	6800	34	8850	6800	44	8850	6800	48	8850	6800
50										24	8000	5500	38	8000	5500	43	8000	5500
55										0	6800	4650	31	6800	4750	37	6800	4750
60													22	5950	4000	30	5950	4000
65													0	5650	3400	21	5650	3400
70																0	5400	2950

On TIRES*

LOAD RADIUS (ft)	MAX BOOM LENGTH (ft)	PICK AND CARRY			
		Stationary		Creep	2.5 MPH
		360° (lb)	OVER FRONT DEFINED ARC (lb)		STRAIGHT OVER FRONT (lb)
10	31	18000	26000	18400	14600
12	31	13700	22900	16200	12800
15	40	10100	19500	13800	10900
20	40	7000	15000	11000	8700
25	45	5000	11000	9000	7300
30	45	3000	7000	7000	6000
35	45	2000	6000	6000	5000
40	53	1500	5000	5000	4000
45	60		3500	3500	3500
50	65		3000	3000	3000
55	70		2000	2000	2000
60	70		1400	1400	1400
65	75		1000		

*Tires (17.5 x 25-20 PR)

Recommended Tire Pressure				
Tire Size	Stationary	Creep	2.5 MPH	Travel
16.00 x 25-32 PR	125 PSI	125 PSI	95 PSI	95 PSI
17.5 X 25-20 PR	90 PSI	90 PSI	90 PSI	70 PSI

NOTES:

- Picking loads above operators compartment is not recommended
- Boom angles are undeflected boom angle
- All specifications subject to change
- Loads in light region are based on structural competence
- Loads in dark region are based on tipping



1. All operators and support personnel shall read and fully understand manufacturer furnished operator's manual, latest applicable American National Standards Institute (ANSI) Safety Standards for Cranes, and any applicable federal, state, or local safety regulations before operating machine. Crane and load ratings comply with ANSI and Power Crane & Shovel Association (PCSA) Standards.

2. All "ON OUTRIGGER" lifts shall be made with outrigger arms fully extended to fully support and level machine (tires off supporting surface). Additional structural blocking or cribbing may be required for some applications.

3. All ratings where shaded background appears are based on 85% of tipping load "ON OUTRIGGERS" and 75% of tipping "ON TIRES" with machine stable on

firm level ground. Ratings where text is without shaded background are based on structural competence. Boom angles are undeflected boom angles.

4. **DO NOT EXCEED** crane load ratings. When load radius or boom angle are between listed values, use the smaller load rating. **DO NOT ATTEMPT TO TIP MACHINE TO DETERMINE ALLOWABLE LOADS.**

5. Weights of hook blocks, bucket, slings, and all other load handling devices are not accounted for in the load chart. The load handling devices must be considered as part of the load.

6. Reduce ratings appropriately for wind conditions, speed of operation, soft or uneven supporting surfaces, etc.

CAUTION - IN WIND OVER 30 MPH, CEASE OPERATION; POSITION BOOM AWAY FROM WIND AND LOWER BOOM BELOW 60°.

IN WIND OVER 50 MPH, FULLY RETRACT AND LOWER BOOM TO LOWEST POSSIBLE POSITION.

7. Load ratings apply to this machine only as originally manufactured and equipped. Unauthorized modification or optional equipment may reduce load capacity. Please consult Badger Equipment **BEFORE** modification or use of optional equipment not covered in this chart.

8. **DO NOT** lift over operator cab.

9. **WARNING** - These load ratings are for lift service only.



Load Chart

WORK AREA DIAGRAMS

On OUTRIGGERS

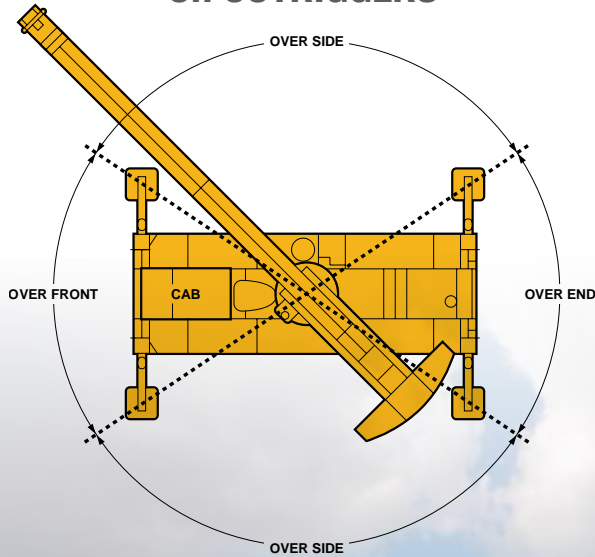

On TIRES

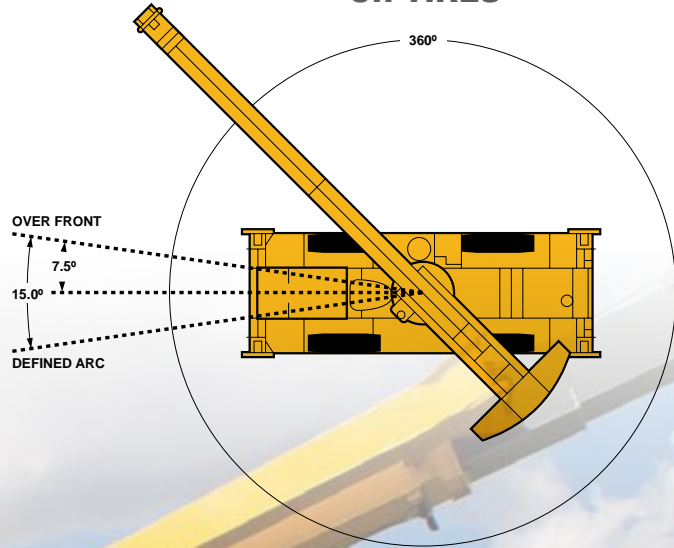

10. Pick and carry load ratings are shown in load chart for on tires. Boom must be above 0°.

11. Load shall be restrained from swinging and shall be positioned as close to the ground as possible over the front along the carrier's lengthwise centerline. **DO NOT** exceed 2.5 MPH (4 Km/h) travel speed using smooth starts and stops. "Creep" is movement not to exceed 200 ft in a 30 min period. Other crane operations **SHALL NOT** be permitted when transporting a load.

OPTIONAL – Foam Filled Tires

RECOMMENDATIONS:

- 5/8" – 6 x 19 Class – 6 x 25 FW, PRF, RRL, XIP, IWRC Wire Rope
- 5/8" XLT4 WireCo Wire Rope



Custom Built in America. For Today. For the Future.



217 Patneau Drive
 Winona, Minnesota 55987
 Phone: (507) 454-1563
 Fax: (507) 453-6441
www.badgerequipment.com



Badger Equipment is a Division of Manitex International, Inc.



CD4430 L

LIFTING CAPACITIES - POUNDS 3 SECTION (30.5' - 76.8' BOOM)

On OUTRIGGERS

LOAD RADIUS (ft)	BOOM LENGTH (ft)																	
	31			40			50			60			70			76.8		
	BOOM ANGLE (deg)	OVER FRONT (lb)	360° (lb)	BOOM ANGLE (deg)	OVER FRONT (lb)	360° (lb)	BOOM ANGLE (deg)	OVER FRONT (lb)	360° (lb)	BOOM ANGLE (deg)	OVER FRONT (lb)	360° (lb)	BOOM ANGLE (deg)	OVER FRONT (lb)	360° (lb)	BOOM ANGLE (deg)	OVER FRONT (lb)	360° (lb)
10	61	60000	60000	68	55000	55000												
12	56	50000	50000	65	50000	50000	70	45000	45000									
15	49	40000	40000	60	40000	40000	66	37500	37500	71	35000	35000						
20	35	30000	25500	51	30000	25500	60	29000	25500	65	28000	25500	69	28000	25500			
25	10	24000	17000	41	24000	17000	53	24000	17000	60	24000	17000	65	22000	17000	67	20000	17000
30				29	20000	14000	46	18000	14000	54	17000	14000	60	16500	14000	63	16500	14000
35				0	17100	10600	37	17000	10600	48	16500	10600	55	15700	10600	59	15000	10600
40							26	11900	8500	41	11900	8500	50	11900	8500	54	11900	8500
45							0	9300	6800	34	9300	6800	44	9300	6800	49	9300	6800
50										24	8000	5500	38	8000	5500	44	8000	5500
55										0	6800	4650	31	6800	4750	39	6800	4750
60													22	5950	4000	32	5950	4000
65													0	5650	3400	24	5650	3400
70																12	5400	2950

On TIRES*

LOAD RADIUS (ft)	MAX BOOM LENGTH (ft)	PICK AND CARRY				20' Jib On Outriggers		
		Stationary		Creep	2.5 MPH	BOOM ANGLE (deg)	BOOM RADIUS (ref ft)	360° (lb)
		360° (lb)	OVER FRONT DEFINED ARC (lb)	STRAIGHT OVER FRONT (lb)				
10	31	18000	33000	25000	21000	70.0	25	14100
12	31	13700	29000	22000	18000	66.7	30	12900
15	40	10100	23000	17500	15000	63.4	35	11850
20	40	7000	15000	13000	11000	60.0	40	10600
25	45	5000	11000	9000	8000	56.6	45	8750
30	45	3000	7000	7000	6000	53.0	50	7350
35	45	2000	6000	6000	5000	49.4	55	6250
40	53	1500	5000	5000	4000	45.5	60	5350
45	60		3500	3500	3500	41.4	65	4600
50	65		3000	3000	3000	37.0	70	4000
55	70		2000	2000	2000	32.2	75	3450
60	70		1400	1400	1400	26.5	80	3000
65	75		1000			19.7	85	2600
						9.7	90	2250

*Tires (16.00 x 25-30 PR)

Deduct 400 lbs. from on tire load chart with jib stored.

Deduct 800 lbs. from on tire load chart with jib erect.

Recommended Tire Pressure

Tire Size	Stationary	Creep	2.5 MPH	Travel
16.00 x 25-32 PLY	125 PSI	125 PSI	125 PSI	95 PSI

1. All operators and support personnel shall read and fully understand manufacturer furnished operator's manual, latest applicable American National Standards Institute (ANSI) Safety Standards for Cranes, and any applicable federal, state, or local safety regulations before operating machine. Crane and load ratings comply with ANSI and Power Crane & Shovel Association (PCSA) Standards.

2. All "ON OUTRIGGER" lifts shall be made with outrigger arms fully extended to fully support and level machine (tires off supporting surface). Additional structural blocking or cribbing may be required for some applications.

3. All ratings where shaded background appears are based on 85% of tipping load "ON OUTRIGGERS" and 75% of tipping "ON TIRES" with machine stable on

firm level ground. Ratings where text is without shaded background are based on structural competence. Boom angles are undeflected boom angles.

4. **DO NOT EXCEED** crane load ratings. When load radius or boom angle are between listed values, use the smaller load rating. **DO NOT ATTEMPT TO TIP MACHINE TO DETERMINE ALLOWABLE LOADS.**

5. Weights of hook blocks, bucket, slings, and all other load handling devices are not accounted for in the load chart. The load handling devices must be considered as part of the load.

6. Reduce ratings appropriately for wind conditions, speed of operation, soft or uneven supporting surfaces, etc.

CAUTION - IN WIND OVER 30 MPH, CEASE OPERATION; POSITION BOOM AWAY FROM WIND AND LOWER BOOM BELOW 60°.

IN WIND OVER 50 MPH, FULLY RETRACT AND LOWER BOOM TO LOWEST POSSIBLE POSITION.

7. Load ratings apply to this machine only as originally manufactured and equipped. Unauthorized modification or optional equipment may reduce load capacity. Please consult Badger Equipment **BEFORE** modification or use of optional equipment not covered in this chart.

8. **DO NOT** lift over operator cab.

9. **WARNING** - These load ratings are for lift service only.

NOTES:

- Picking loads above operators compartment is not recommended
- Boom angles are undeflected boom angle
- All specifications subject to change
- Loads in light region are based on structural competence
- Loads in dark region are based on tipping



Load Chart

WORK AREA DIAGRAMS

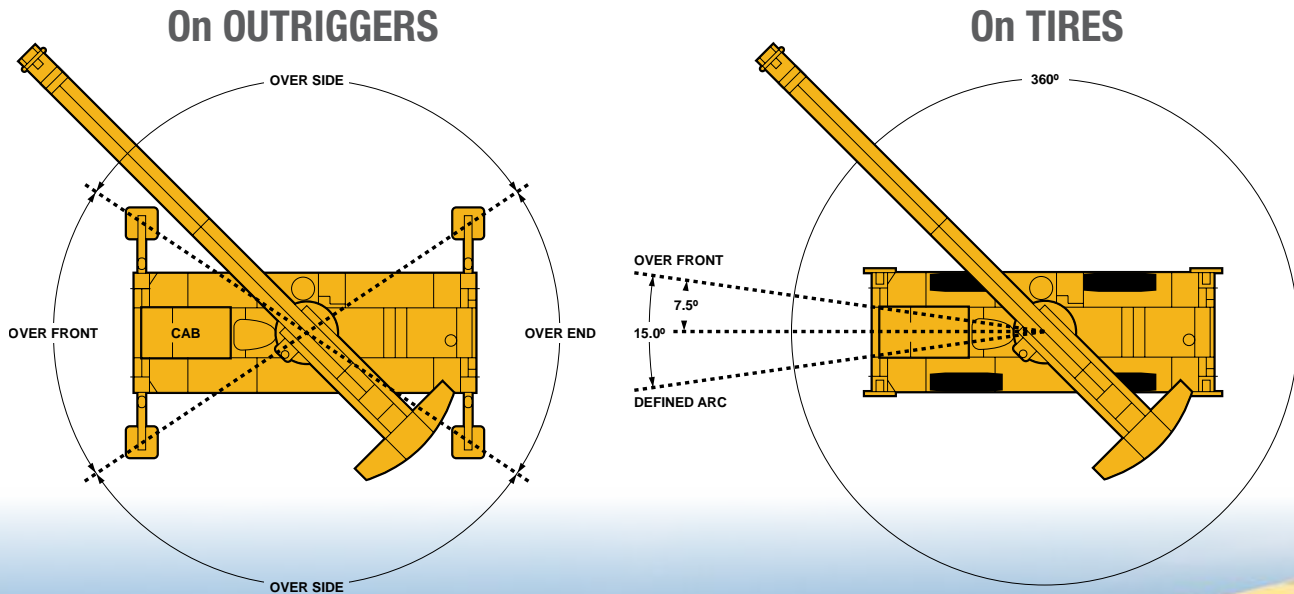

10. Pick and carry load ratings are shown in load chart for on tires. Boom must be above 0°.

11. Load shall be restrained from swinging and shall be positioned as close to the ground as possible over the front along the carrier's lengthwise centerline. **DO NOT** exceed 2.5 MPH (4 Km/h) travel speed using smooth starts and stops. "Creep" is movement not to exceed 200 ft in a 30 min period. Other crane operations **SHALL NOT** be permitted when transporting a load.

OPTIONAL – Foam Filled Tires

RECOMMENDATIONS:

- 5/8" – 6 x 19 Class – 6 x 25 FW, PRF, RRL, XIP, IWRC Wire Rope
- 5/8" XLT4 WireCo Wire Rope



Custom Built in America. For Today. For the Future.



217 Patneau Drive
 Winona, Minnesota 55987
 Phone: (507) 454-1563
 Fax: (507) 453-6441
www.badgerequipment.com



Badger Equipment is a Division of Manitex International, Inc.



General Dimensions

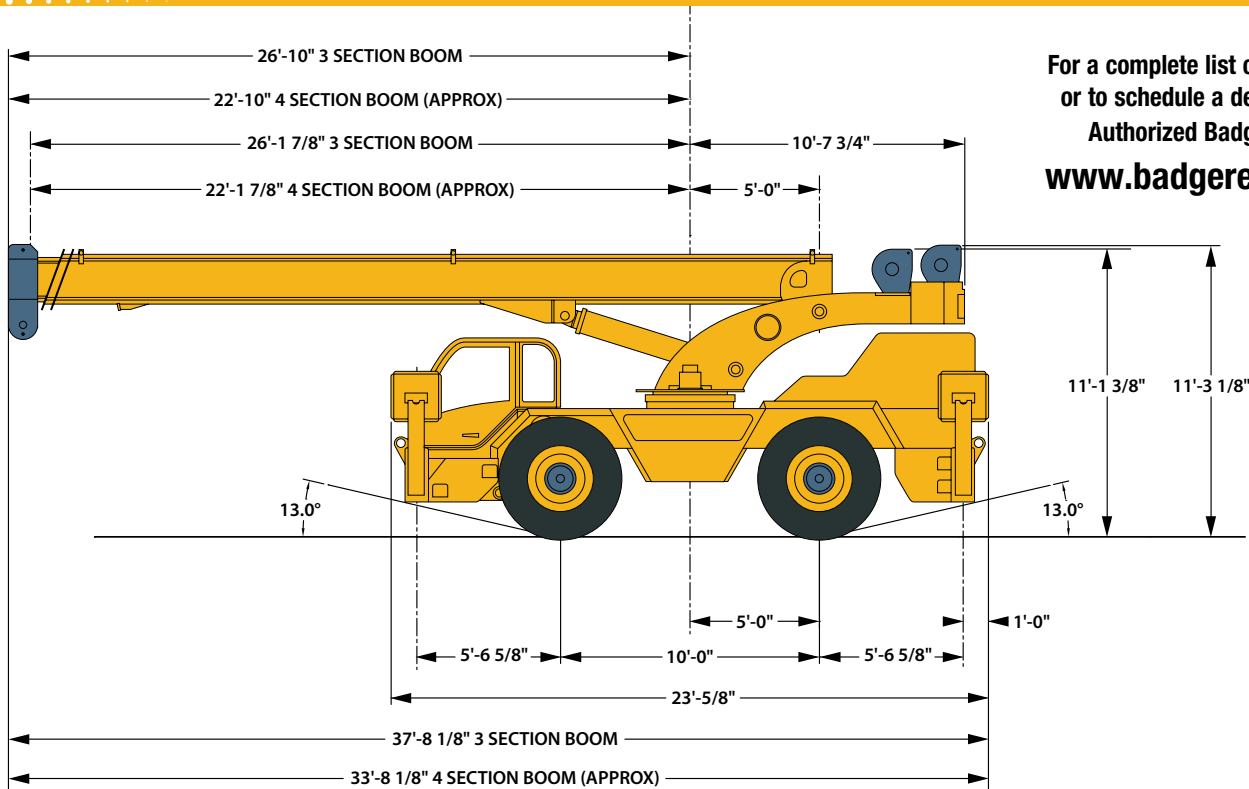

For a complete list of optional equipment or to schedule a demo please see your Authorized Badger Dealer or visit www.badgerequipment.com

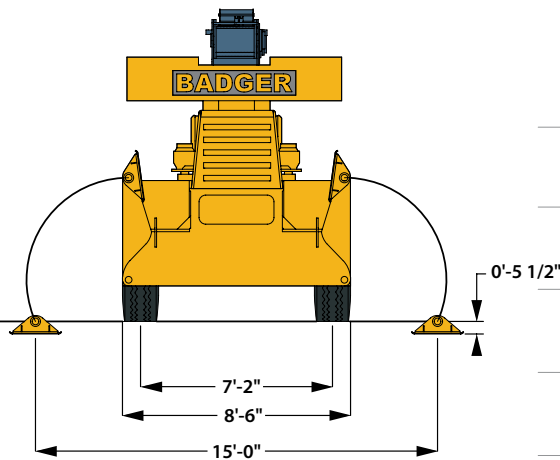

Top Height

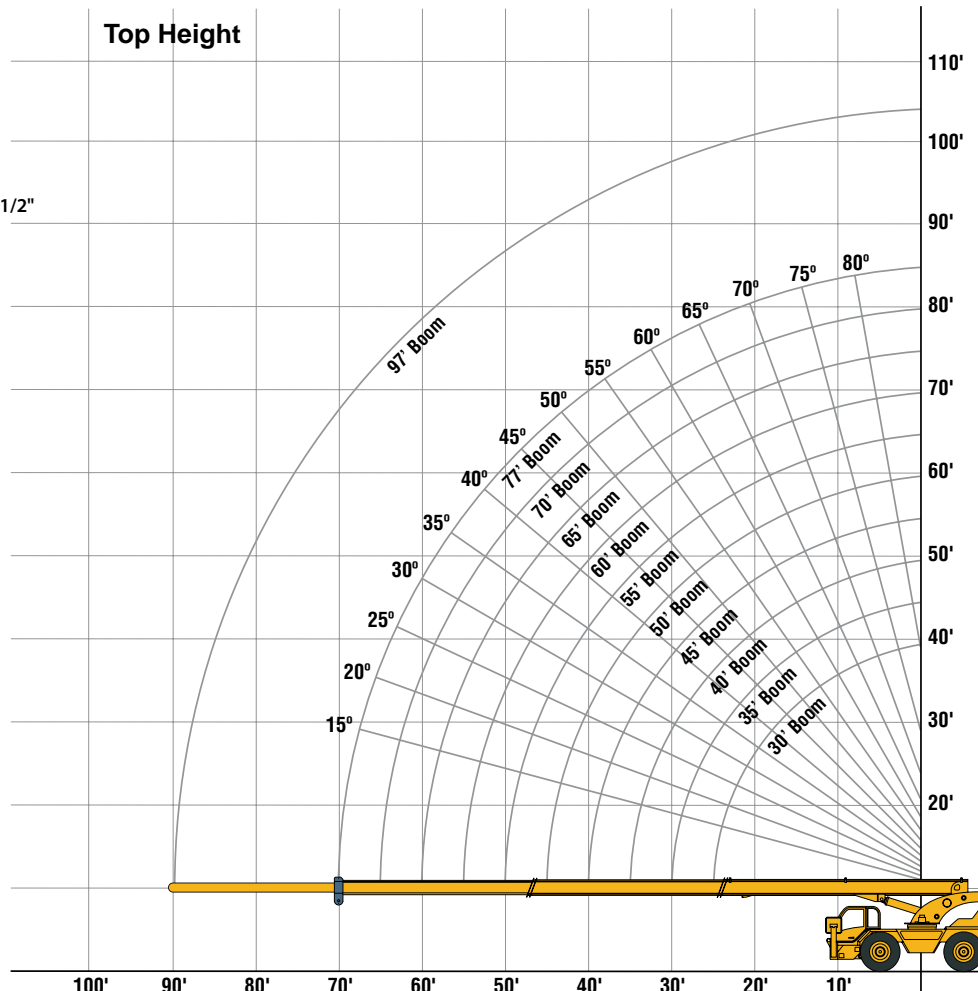

Custom Built in America. For Today. For the Future.



Made in the USA

217 Patneau Drive
Winona, Minnesota 55987
Phone: (507) 454-1563
Fax: (507) 453-6441
www.badgerequipment.com



Badger Equipment is a Division of Manitex International, Inc.