

- Specifications
- Working ranges main boom
- Lifting capacities main boom
- Working ranges main boom extension
- Lifting capacities main boom extension
- Technical description

## Demag AC 25

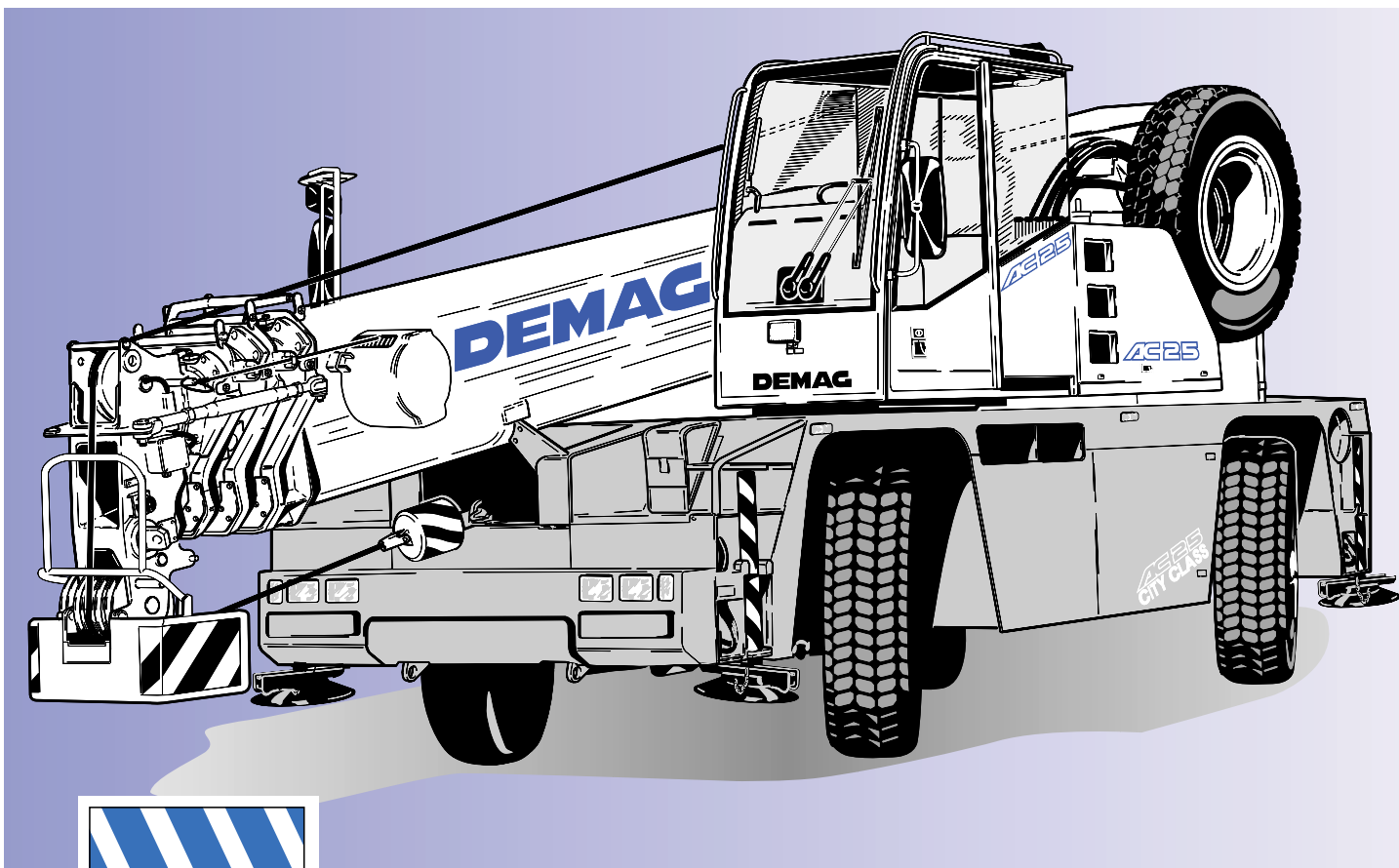

**28t**

# Dimensions

Type of tires	Level	A*	B*	C*	D*
14.00	Road	10'5"	10'	1'1"	5'
14.00	Lowered	10'2"	9'7"	8"	4'7"
425/65	Road	10'1"	9'6"	7"	4'6"
425/65	Lowered	9'8"	9'3"	4"	4'3"

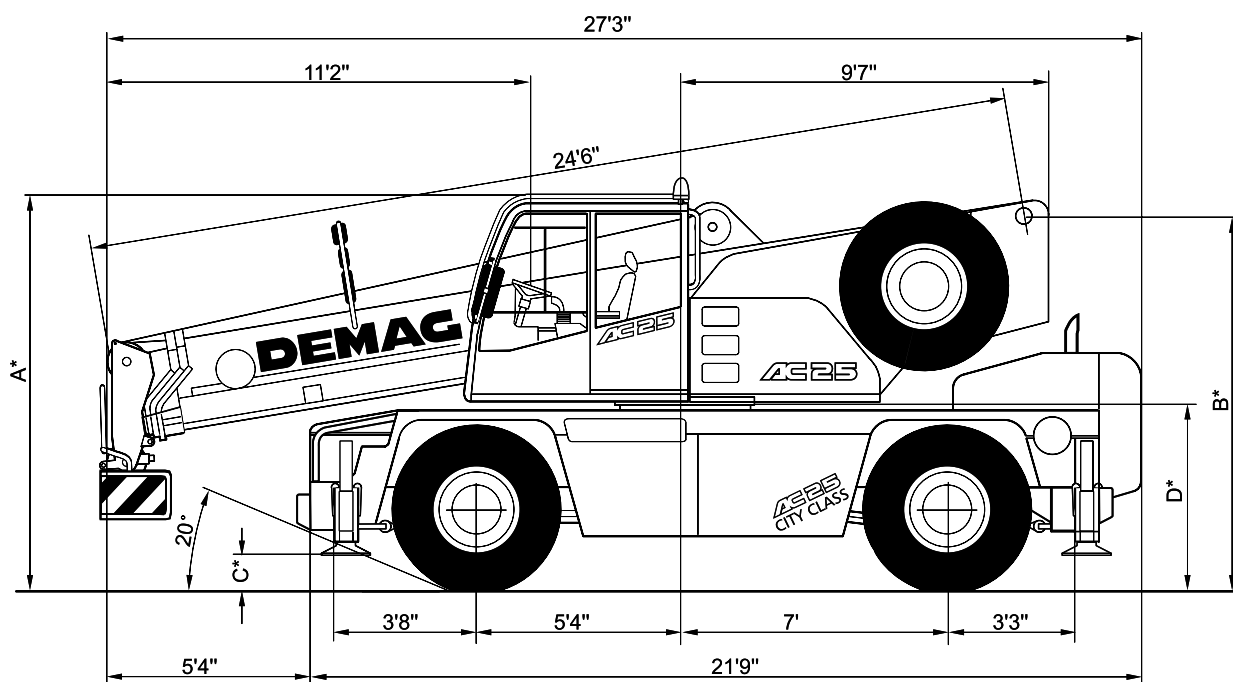

# Dimensions

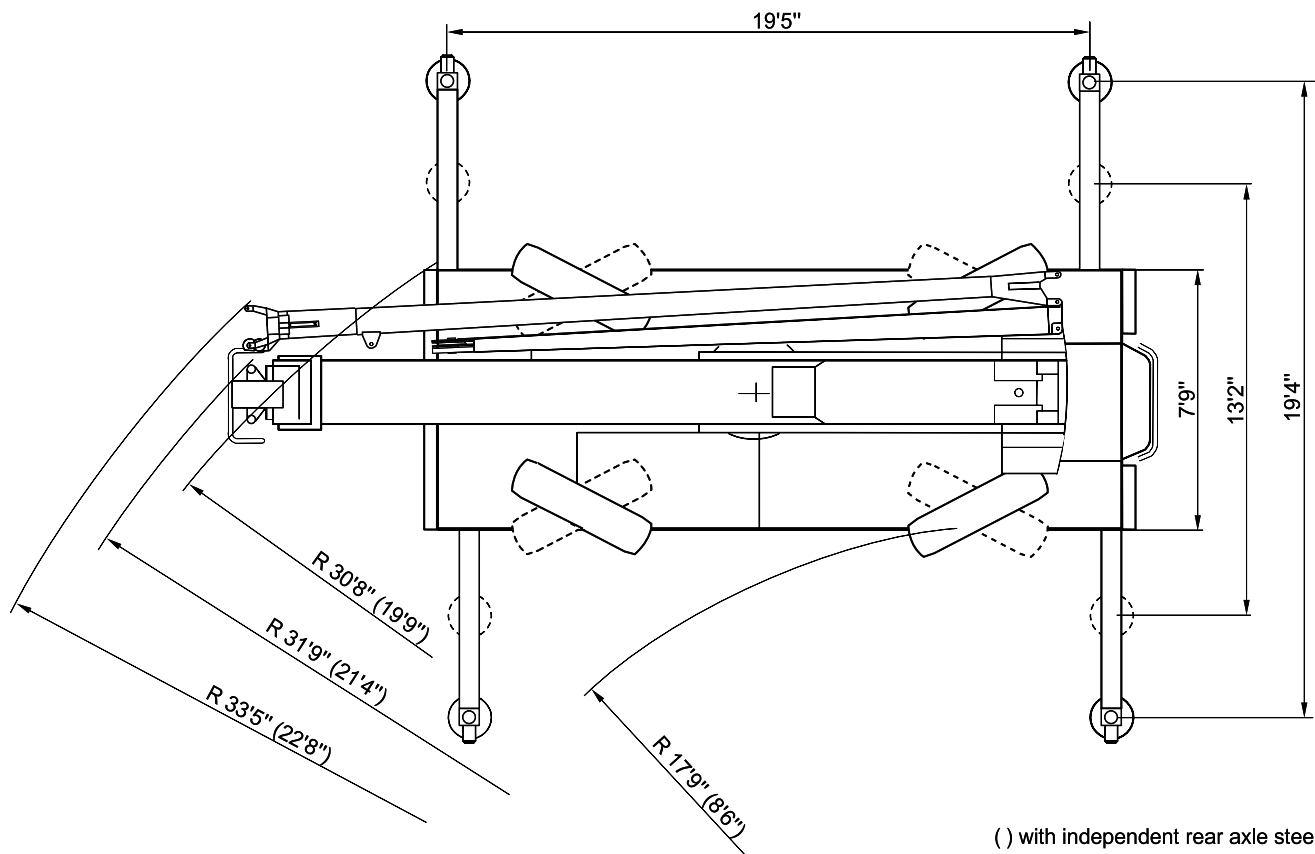



( ) with independent rear axle steering

# Key

---

 Lifting capacities on outriggers 360°

 free on wheels

„D“  D

## Notes to lifting capacity

Lifting capacities do not exceed 85% of tipping load.  
Weight of hook blocks and slings are part of the load, and are to be deducted from the capacity ratings.

Crane operation with main boom is permissible up to a  
wind speed of ..... 32 ft/s

Consult operation manual for further details on wind speed.  
All capacities above the parting line are based on structural strength. Capacities below the parting line are based on machine stability.  
Crane operation subject to computer charts, only! For crane operation consult operation manual first!

# Specifications

## Axle loads

Crane in travel position  
Axles  
Total weight

axle 1	18,700 lb
axle 2	24,250 lb
	<hr/> 42,950 lb

## Working speeds (infinitely variable)

Mechanisms	Normal speed	High speed	Max. permissible line pull <sup>3)</sup>	Rope length
Hoist	180.4 ft/min	344.4 ft/min	6,400 lb	426.5 ft
Slewing				max. 1.7 1/min
Telescoping speed				24.6 – 82.0 ft: 60 s
Boom elevation				-10° – +78°: 50 s

## Carrier performance

Travel speed	0..50/53 mph <sup>1)</sup>
Gradeability	max. 50/80% <sup>2)</sup>
Ground clearance	1' / 1'4" <sup>1)</sup>

## Hook block/Heavy-lift attachment

Type	Possible load <sup>3)</sup>	Number of sheaves	Weight	„D“	Number of lines	Heavy-lift attachment
32	55,000 lb	5	485 lb	5'9"	10	1 add. sheave
25	44,800 lb	3	353 lb	5'2"	7	
25 <sup>4)</sup>	44,800 lb	3	353 lb	3'8"	7	
10	19,200 lb	1	220 lb	5'2"	3	
3,2	6,400 lb		176 lb	4'9"	1	



## Remarks

- <sup>1)</sup> depending on type of tires
- <sup>2)</sup> Drive 4 x 2 / 4 x 4
- <sup>3)</sup> varies depending on national regulations
- <sup>4)</sup> for workshop operation

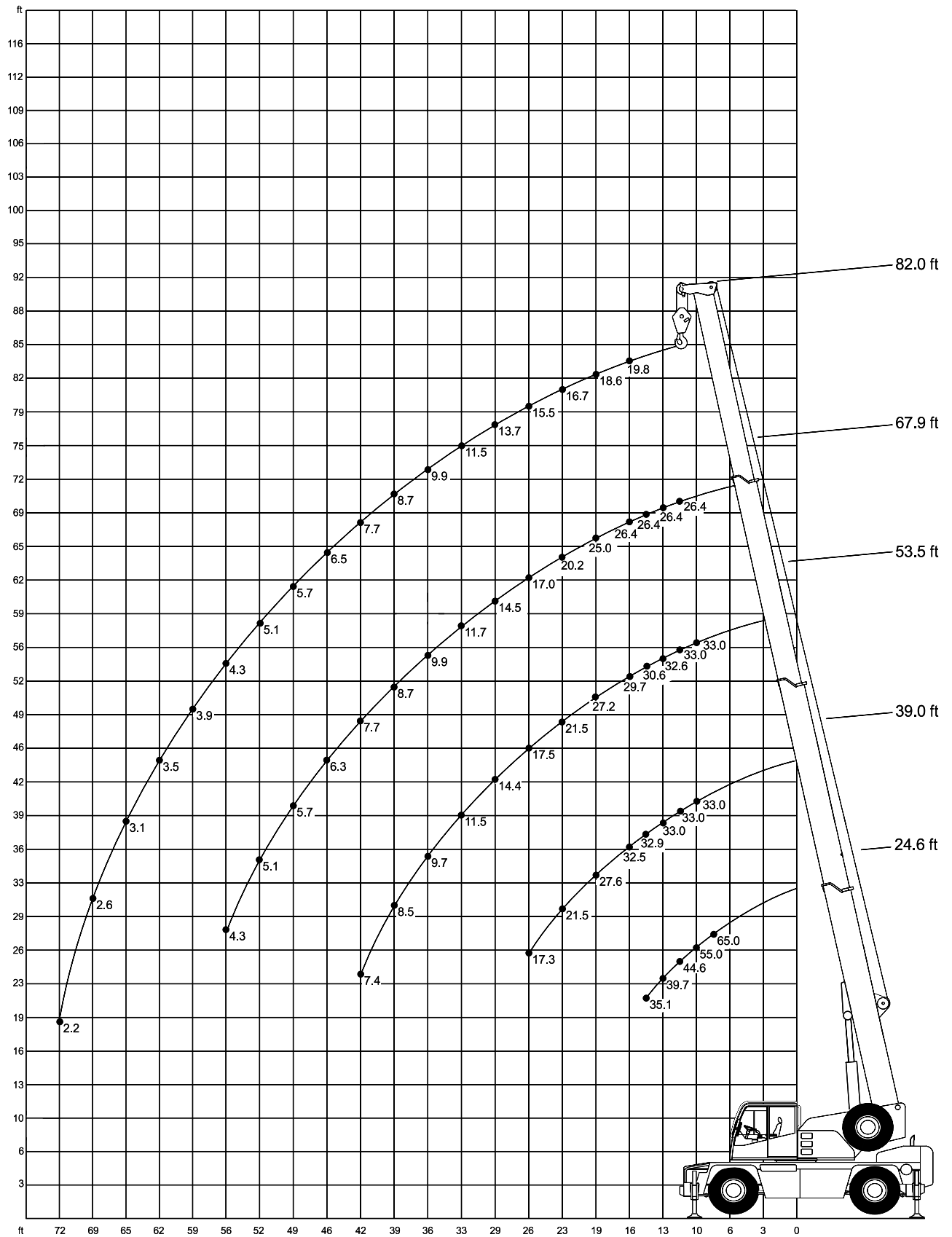
# Working ranges main boom



# Lifting capacities main boom



 <b>19'6" x 19'4" 360° 85%</b>						 <b>19'6" x 13'2" 360° 85%</b>					
Main boom						Main boom					
Radius	24.6 ft	39.0 ft	53.5 ft	67.9 ft	82.0 ft	Radius	24.6 ft	39.0 ft	53.5 ft	67.9 ft	82.0 ft
ft	1,000 lb					ft	1,000 lb				
8	65.0 <sup>3)</sup>	-	-	-	-	8	-	-	-	-	-
10	55.0*/47.0	33.0	33.0	-	-	10	41.6	33.0	32.9	-	-
11	44.6	33.0	33.0	26.4	-	11	38.9	33.0	31.9	27.2	-
13	39.7	33.0	32.6	26.4	-	13	30.9	30.2	26.8	24.0	-
15	35.1	32.9	30.6	26.4	-	15	22.8	23.8	22.2	20.3	-
16	-	32.5	29.7	26.4	19.8	16	-	21.1	20.5	18.8	17.2
19	-	27.6	27.2	25.0	18.6	19	-	15.5	15.6	15.3	14.1
23	-	21.5	21.5	20.2	16.7	23	-	10.7	11.0	11.4	11.0
26	-	17.3	17.5	17.0	15.5	26	-	8.7	8.9	9.2	9.1
29	-	-	14.4	14.5	13.7	29	-	-	7.5	7.5	7.7
33	-	-	11.5	11.7	11.5	33	-	-	5.9	6.1	6.1
36	-	-	9.7	9.9	9.9	36	-	-	5.0	5.1	5.3
39	-	-	8.5	8.7	8.7	39	-	-	4.2	4.4	4.5
42	-	-	7.4	7.7	7.7	42	-	-	3.6	3.8	3.8
46	-	-	-	6.3	6.5	46	-	-	-	3.2	3.2
49	-	-	-	5.7	5.7	49	-	-	-	2.6	2.8
52	-	-	-	5.1	5.1	52	-	-	-	2.2	2.4
56	-	-	-	4.3	4.3	56	-	-	-	1.7	2.1
59	-	-	-	-	3.9	59	-	-	-	-	1.7
62	-	-	-	-	3.5	62	-	-	-	-	1.5
65	-	-	-	-	3.1	65	-	-	-	-	1.3
69	-	-	-	-	2.6	69	-	-	-	-	1.0
72	-	-	-	-	2.2	72	-	-	-	-	-
Capacities <sup>2)</sup>	28.3	11.0	6.1	3.3	1.7	Capacities <sup>2)</sup>	19.8	5.5	2.6	1.1	-



 <b>19'6" x 7'4" 85%</b>			
Main boom			
Radius	24.6 ft	39.0 ft	53.5 ft
ft	1,000 lb		
10	30.5	31.8	28.5
11	23.3	24.3	24.0
13	18.4	19.4	19.7
15	15.1	16.1	16.4
16	-	13.5	13.8
19	-	9.8	10.2
23	-	7.5	7.9
26	-	5.9	6.2
29	-	-	4.9
33	-	-	3.9
36	-	-	3.3
Capacities <sup>2)</sup>	8.8	2.2	-

## Remarks

- \* 0° over rear
- \*\* only stationary
- 1) type of tires 14.00
- 2) with horizontal boom
- 3) 180° over front

# Lifting capacities main boom

 <b>0° / 180°</b> <b>85%</b>				 <b>360° **</b> <b>85%</b>			
Radius	Main boom			Radius	Main boom		
	24.6 ft <sup>1)</sup>	39.0 ft <sup>1)</sup>	53.5 ft <sup>1)</sup>		24.6 ft <sup>1)</sup>	39.0 ft <sup>1)</sup>	53.5 ft <sup>1)</sup>
ft	1,000 lb			ft	1,000 lb		
10	21.3	21.8	22.0	10	–	–	–
11	20.0	20.4	20.7	11	12.8	13.5	13.7
13	17.5	18.0	18.2	13	10.9	11.3	11.5
15	15.6	16.0	16.3	15	9.0	9.7	9.9
16	–	15.1	15.3	16	–	8.9	9.1
19	–	12.8	13.0	19	–	6.6	6.9
23	–	9.4	9.6	23	–	4.6	4.8
26	–	7.6	7.8	26	–	3.8	3.8
29	–	6.3	6.6	29	–	3.0	3.1
33	–	–	5.2	33	–	–	2.3
36	–	–	4.4	36	–	–	1.9
39	–	–	3.8	39	–	–	–
42	–	–	3.2	42	–	–	–
Capacities <sup>2)</sup>	14.3	5.5	2.2	Capacities <sup>2)</sup>	7.7	2.2	–

 <b>0° / 180°</b> <b>85%</b>				 <b>360° **</b> <b>85%</b>			
Radius	Main boom			Radius	Main boom		
	24.6 ft	39.0 ft	53.5 ft		24.6 ft	39.0 ft	53.5 ft
ft	1,000 lb			ft	1,000 lb		
10	16.8	17.4	17.4	10	–	–	–
11	15.7	16.2	16.3	11	10.5	10.9	11.4
13	13.7	14.2	14.4	13	8.7	9.3	9.5
15	12.1	12.6	12.8	15	7.3	7.8	8.0
16	–	11.9	12.0	16	–	7.2	7.4
19	–	10.1	10.2	19	–	5.8	6.0
23	–	8.1	8.3	23	–	4.4	4.6
26	–	7.1	7.3	26	–	3.5	3.8
29	–	6.3	6.3	29	–	2.7	3.0
33	–	–	5.2	33	–	–	2.3
36	–	–	4.4	36	–	–	1.7
39	–	–	3.8	39	–	–	–
42	–	–	3.2	42	–	–	–
Capacities <sup>2)</sup>	11.0	5.3	2.0	Capacities <sup>2)</sup>	6.6	2.2	–

## Remarks

- \* 0° over rear / 180° over front
- \*\* only stationary
- <sup>1)</sup> type of tires 14.00
- <sup>2)</sup> with horizontal boom



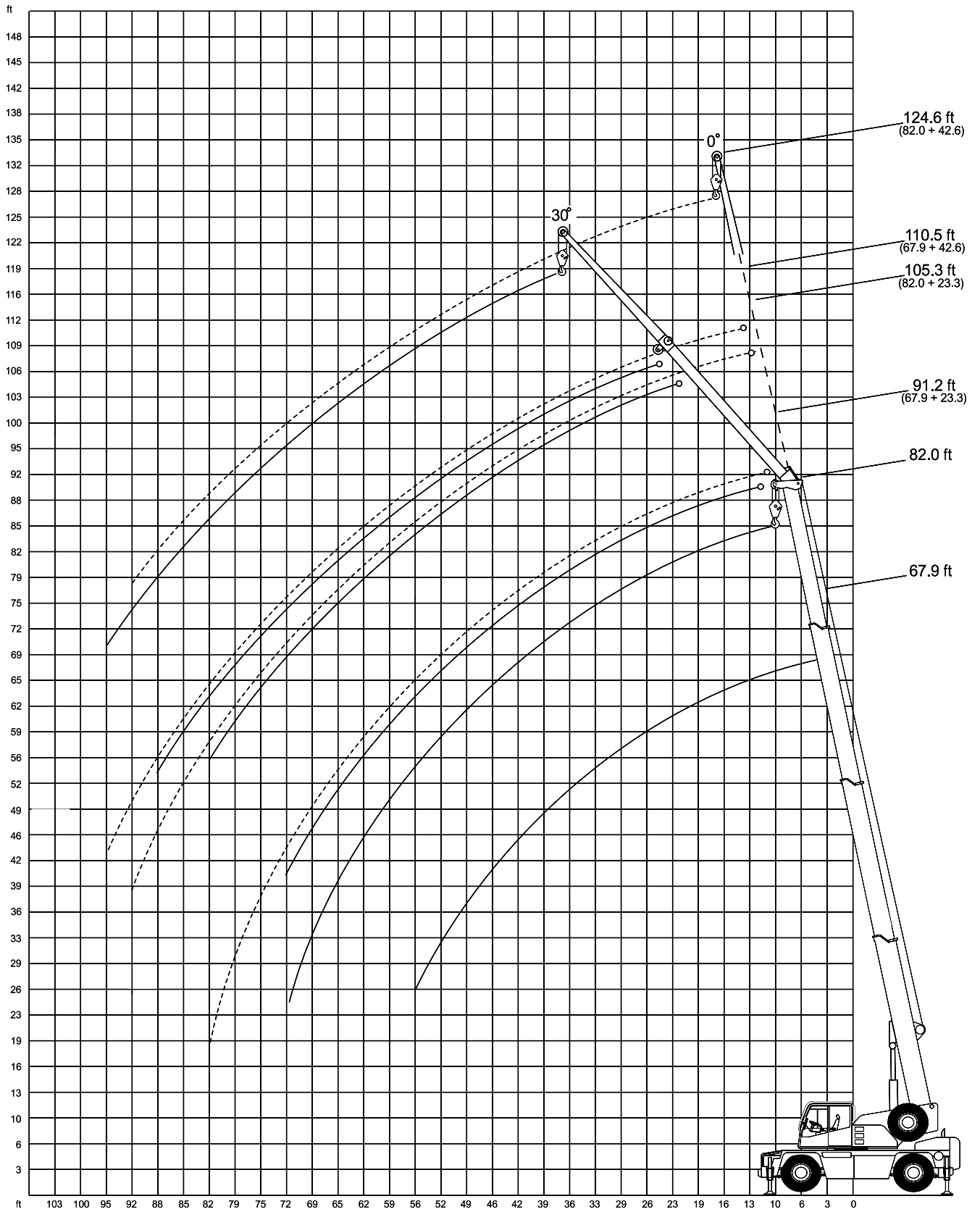

# Working ranges main boom extension





# Lifting capacities main boom extension

Main boom: 67.9 ft

 <b>360°</b> <b>19'6" x 19'4"</b> <b>85%</b>					 <b>360°</b> <b>19'6" x 13'2"</b> <b>85%</b>				
Radius	Extension				Radius	Extension			
	23.3 ft		42.6 ft			23.3 ft		42.6 ft	
	0°	30°	0°	30°		0°	30°	0°	30°
ft	1,000 lb				ft	1,000 lb			
16	12.3	-	-	-	16	12.3	-	-	-
19	12.3	-	-	-	19	12.3	-	-	-
23	11.6	-	4.8	-	23	11.6	-	4.8	-
26	11.0	-	4.8	-	26	9.6	-	4.8	-
29	10.4	8.1	4.8	-	29	8.0	8.2	4.8	-
33	9.6	7.9	4.6	-	33	6.3	7.2	4.6	-
36	9.2	7.7	4.6	-	36	5.5	6.2	4.6	-
39	8.8	7.5	4.4	-	39	4.7	5.3	4.4	-
42	7.9	7.3	4.2	3.7	42	4.0	4.7	4.2	3.7
46	6.8	7.0	4.1	3.5	46	3.5	3.9	3.5	3.5
49	6.0	6.6	3.9	3.5	49	3.1	3.3	3.1	3.5
52	5.3	5.8	3.7	3.3	52	2.7	2.9	2.7	3.3
56	4.8	5.0	3.5	3.2	56	2.1	2.6	2.3	3.0
59	4.2	4.6	3.5	3.0	59	1.7	2.2	1.9	2.6
62	3.7	4.0	3.3	3.0	62	1.5	1.8	1.7	2.4
65	3.3	3.4	3.1	3.0	65	1.1	1.4	1.5	2.0
69	2.8	2.8	3.0	2.8	69	-	1.0	1.3	1.5
72	2.4	-	2.8	2.8	72	-	-	1.1	1.3
75	2.0	-	2.4	2.8	75	-	-	-	1.1
79	1.7	-	2.1	2.6	79	-	-	-	-
82	1.5	-	1.9	2.2	82	-	-	-	-
85	-	-	1.7	2.0	85	-	-	-	-
88	-	-	1.5	1.6	88	-	-	-	-
92	-	-	1.3	-	92	-	-	-	-
95	-	-	1.1	-	95	-	-	-	-

Main boom: 82.0 ft

 <b>360°</b> <b>19'6" x 19'4"</b> <b>85%</b>					 <b>360°</b> <b>19'6" x 13'2"</b> <b>85%</b>				
Radius	Extension				Radius	Extension			
	23.3 ft		42.6 ft			23.3 ft		42.6 ft	
	0°	30°	0°	30°		0°	30°	0°	30°
ft	1,000 lb				ft	1,000 lb			
23	9.9	-	-	-	23	9.9	-	-	-
26	9.7	-	4.4	-	26	9.3	-	4.4	-
29	9.3	-	4.4	-	29	7.9	-	4.4	-
33	8.8	7.4	4.4	-	33	6.3	7.2	4.4	-
36	8.6	7.2	4.4	-	36	5.3	6.2	4.4	-
39	8.2	7.0	4.2	-	39	4.7	5.3	4.2	-
42	7.8	6.8	4.1	-	42	4.0	4.5	4.0	-
46	6.6	6.6	3.9	3.3	46	3.2	3.9	3.5	3.3
49	5.9	6.4	3.9	3.3	49	2.8	3.3	3.1	3.3
52	5.3	5.8	3.7	3.3	52	2.4	2.9	2.7	3.3
56	4.5	5.0	3.7	3.0	56	2.1	2.4	2.1	3.0
59	3.9	4.4	3.5	3.0	59	1.7	2.2	1.9	2.6
62	3.5	4.0	3.5	3.0	62	1.5	1.8	1.5	2.2
65	3.1	3.6	3.3	2.9	65	1.1	1.4	1.3	2.0
69	2.8	3.0	2.8	2.8	69	-	1.0	1.0	1.5
72	2.4	2.6	2.6	2.8	72	-	-	-	1.3
75	2.0	2.2	2.2	2.8	75	-	-	-	1.1
79	1.7	1.9	1.9	2.6	79	-	-	-	-
82	1.5	1.5	1.7	2.2	82	-	-	-	-
85	1.3	-	1.5	2.0	85	-	-	-	-
88	1.1	-	1.3	1.8	88	-	-	-	-
92	-	-	1.0	1.5	92	-	-	-	-
95	-	-	-	1.3	95	-	-	-	-

# Technical description

## Carrier

<b>Drive/Steering Frame</b>	4 x 2 x 4. Anti-torsion monobox main frame with integrated outrigger boxes, fabricated of high strength fine grain structural steel. Tow lugs integrated on front and rear.
<b>Outriggers</b>	Max. outrigger base, longitudinal: 19.6 ft, transverse: 19.4 ft. Four hydraulic outriggers, controlled from each side of the chassis, monitored by bubble levelling indicator, jacking cylinder stroke approx. 1.8 ft. The outrigger floats remain fitted to the jacking cylinders during transit, without exceeding the 7.9 ft overall width of the crane. Programming for 2nd outrigger base.
<b>Engine</b>	Water-cooled 6-cylinder Perkins Phaser 210 TI engine, anti-pollution conforming to „EURO I“, output to DIN: 156 kW (212 hp) at 2500 1/min, torque 737 Nm at 1550 1/min, fuel tank capacity 69 gallons, aluminized steel exhaust system.
<b>Transmission</b>	Allison automatic transmission with torque converter, six speeds forward and one reverse.
<b>Axles</b>	Axle 1: planetary, steer, with transverse differential lockout; axle 2: rigid.
<b>Weight in travel order</b>	45,000 lb.
<b>Suspension</b>	All axles with hydropneumatic suspension, hydraulically blockable.
<b>Wheels and tires</b>	4 wheels 425/65 R 22.5.
<b>Travel speed</b>	50 mph.
<b>Steering</b>	ZF dual-circuit hydraulic steering with mechanical steering end stop. One engine-driven master steering pump, one emergency steering pump.
<b>Brakes</b>	Service brake: dual-line air system; parking brake: spring-loaded brake on rear axle; sustained action brake: exhaust brake.
<b>Electrical system</b>	24 V. 3-phase alternator 55 A. Two batteries 12 V / 180 Ah. CTC computer control, specially developed for demanding mobile applications. The system includes pilot lamps to assist in trouble shooting.

## Superstructure

<b>Steel structure</b>	Welded structure fabricated of fine grain steel. Anti-torsion frame of weight-saving longitudinal beam construction.
<b>Engine</b>	Powered by carrier engine.
<b>Hydraulic system</b>	One variable-displacement axial piston pump for main working movements, separate pump for slew unit. This provides for three simultaneous and independent working movements. Reservoir capacity: 91 gallons.
<b>Hoist</b>	Fixed-displacement axial piston hydraulic motor, hoist drum with integrated planetary gear reducer and spring-applied multi-disk brake. Drum diameter: 9”.
<b>Slew unit</b>	Hydraulic motor with planetary gear reducer, pedal-operated service brake and spring-applied holding brake. Slewing speed infinitely variable.
<b>Boom elevation Control</b>	One differential cylinder with pilot-controlled lowering brake valve. The crane is controlled by two self-centering servo levers. Working speed control by both lever position and engine speed. Hydro-electric pilot control with emergency program.
<b>Crane cab</b>	One-man cab with full crane and travel controls. All-steel comfortable cab with sliding door and large hinged window, safety glazing throughout. Roof window with amoured-glass, slide-by side window, sprung and adjustable operator's seat incl. head and arm rests, and seat belt. Washer and parallel wiper for cab window and roof window. Self-contained thermostat-controlled hot water heater with timer. Load moment limiter.
<b>Main boom</b>	Boom base and three telescopic sections fabricated from fine grain structural steel, telescoping to full boom length by hydraulic cylinder and rope pulley assembly. Boom head with four sheaves and parts to fit the optional boom extension. Overall length 82 ft.
<b>Counterweight Safety devices</b>	Integrated into the superstructure. Electronic safe load indicator is installed as standard, with sealed touch-type keyboard, incl. digital read-out for hook load, rated load, boom length, boom angle and load radius and analog display to indicate the capacity utilization in percent. Simple and easy 4-key operation.

## Other equipment

Fire extinguisher, two working lights, two spotlights to illuminate the outrigger area, antislip on carrier, manual windmeter, spacious stowage facilities and tool kit.  
2 pack acrylic paint. Superstructure: RAL 9003 signal white, carrier: RAL 7037 dusty grey.

# Technical description

## Options

<b>Drive/Steering</b>	4 x 4 x 4. Axle 1: planetary, steer, with transverse differential lockout. Axle 2: planetary, steer, connectable, independent rear axle steering, transverse differential lockout. Turning radius with all-wheel steer: 21.7 ft.
<b>Wheels and tires</b>	14.00 R 25. Overall crane width 7.9 ft, overall crane height 10.6 ft. Spare wheel either loose or with mount and hoisting mechanism.
<b>Main boom extension</b>	1- or 2-part extension, offsettable at 0° and 30°. 1-part box type extension: 23.3 ft. 2-part box type extension: 23.3 ft or 42.6 ft. Folds to right side of boom base during transit. Overall boom length: 124.6 ft, max. tip height: 132 ft.
<b>Centralized lubrication</b>	for carrier.
<b>ABS</b>	Anti-lock brake system.
<b>Other equipment</b>	Exhaust with spark arrestor, airconditioner, phone, windmeter on boom head, rotating beacon, hydraulic oil cooler, tropicalization, radio and cool-box.
<b>National regulations</b>	Different requirements for crane acceptance and roadability in different countries.
<b>Specialpainting and special lettering</b>	Special customized lettering and all RAL colors.
<b>Additional sheave required on main boom head</b>	for loads > 51,100 lb.
<b>Heavy-lift runner</b>	3.9 ft long, 3-sheave, for workshop operation. Stowed on carrier during transit.