

Hydraulic Crawler Crane

FWX 135

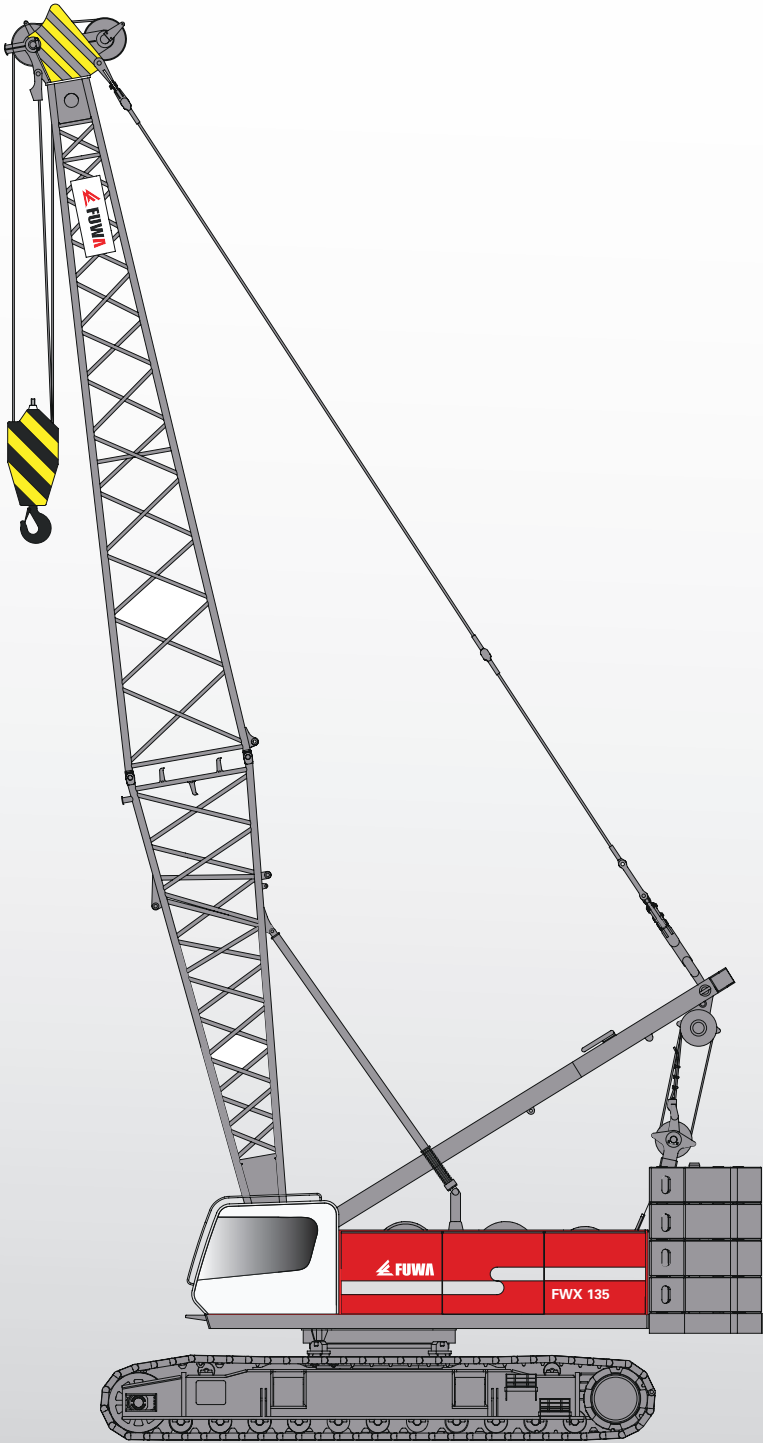



Fuwa Heavy Industry Co.Ltd.

Foreword

Thank you for your interest in our products.

Fuwa Heavy Industry Co. Ltd. is one of the oldest manufacturers in the heavy equipment industry. Our history goes back to 1904. Today Fuwa is a modern contender on both the Chinese domestic market and the advanced International market.

A team of experts and engineers has reset the concept of crawler cranes by searching the optimum in international design and technology combined with the dedicated manufacturing in China.

The use of our long term experience combined with modern computer design, calculation and simulation software, enabled us to reach the best to meet the customers demand.

New standards on safety, quality, performance, reliability, easy transport and maintenance have been implemented. We respect the environment by efficient use of true materials, high quality components and aim a long life time.

The unique concept of Modular Design offers a large variety of models, but always based on the same key values.

FWX135 Features

Modular design for optimized performance and efficient maintenance by innovative layout of hydraulic and electric system. High-grade steel boom and machine structures thoroughly engineered and analyzed. High Performance winches with 22 or 26mm wire rope and optional free fall functions for special applications.

Life-Cab; high ergonomics comfort cab, 20% more vision offered by flat and easy maintenance windows, 20% larger door entrance. Self-assembly devices for safe and efficient assembly of track-frames, counterweights and boom foot. Jack-up cylinders in drop and jack-up style for safe lifting the base machine.

Powerful traction and good stability when traveling, even with 100% load. Logic organized control consoles, with enhanced monitor display, lightning strike protected, GPS locator. Enhanced Moment Limiter system with multi-function display including machine diagnostics. A solid state-of-art electronic compartment hosts all electric functions in a fix setup for fast checking and maintenance.

Excellent transport possibilities of the main structure with a width of just 3 meters. Main boom inserts of 3m, 6m and 11,6m allow containerized transport. Multi-configurations and options to serve various markets and applications to meet most different requirements.

The FWX machines carry the new Fuwa Signature of quality;
respect the past, aim the future.



Contents

● Overall Demension	1
● Technical Data	4
● Specifications	5
● Machine Configuration	6
● Notes for Load Chart	8
● Working Range - Main Boom	9
● Main Boom Load Chart	10
● Working Range - Runner	11
● Runner Load Chart	12
● Working Range - Fly Jib	13
● Fly Jib Load Chart	14
● Working Range -Luffing Jib	19
● Luffing Jib Load Chart	20
● Safety Devices	32
● Boom Combinations	33
● Transportation Dimensions and Weights	35
● Self-assembling Principle	40



Overall Dimension

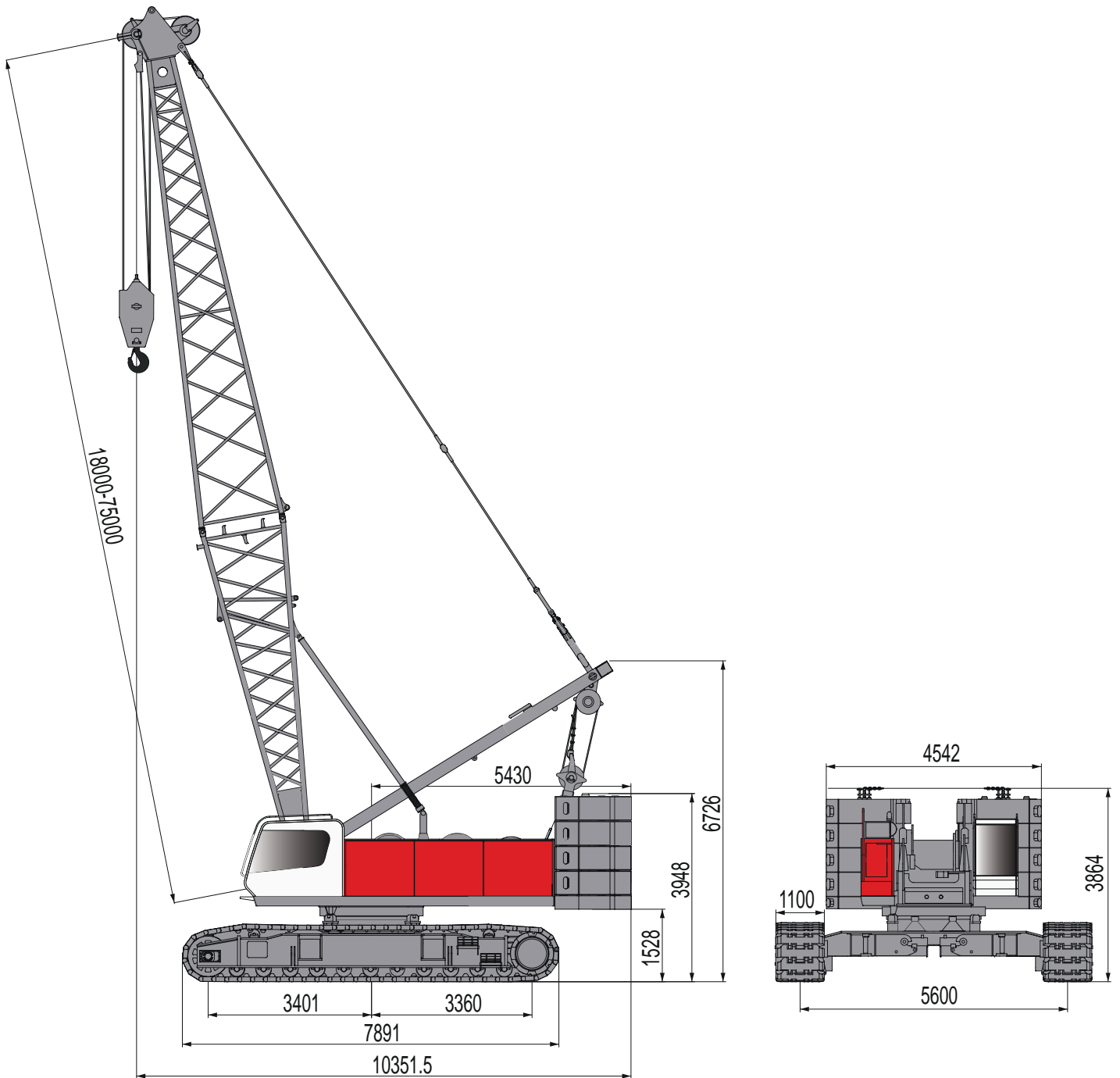



Overall Dimension

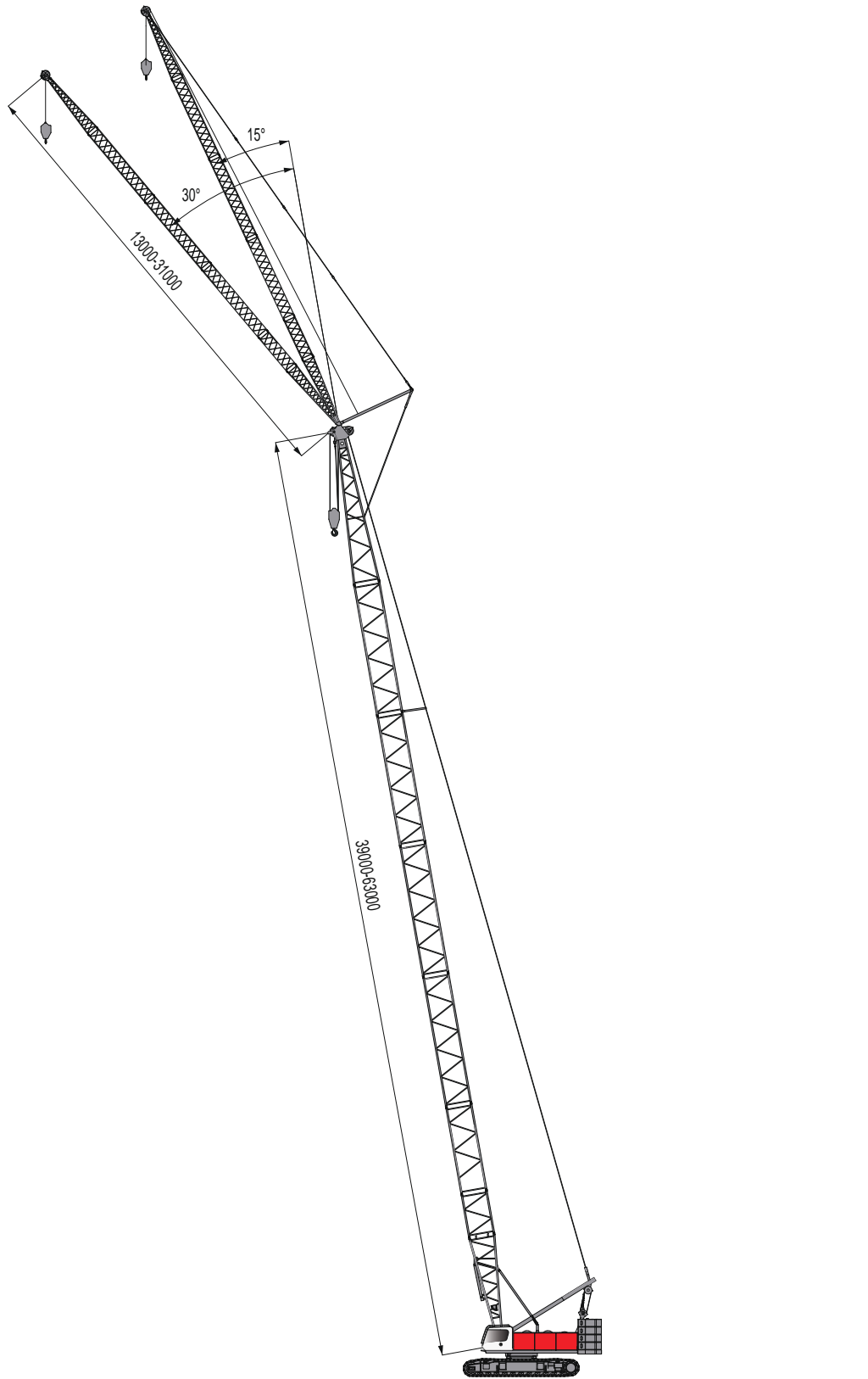



Overall Dimension

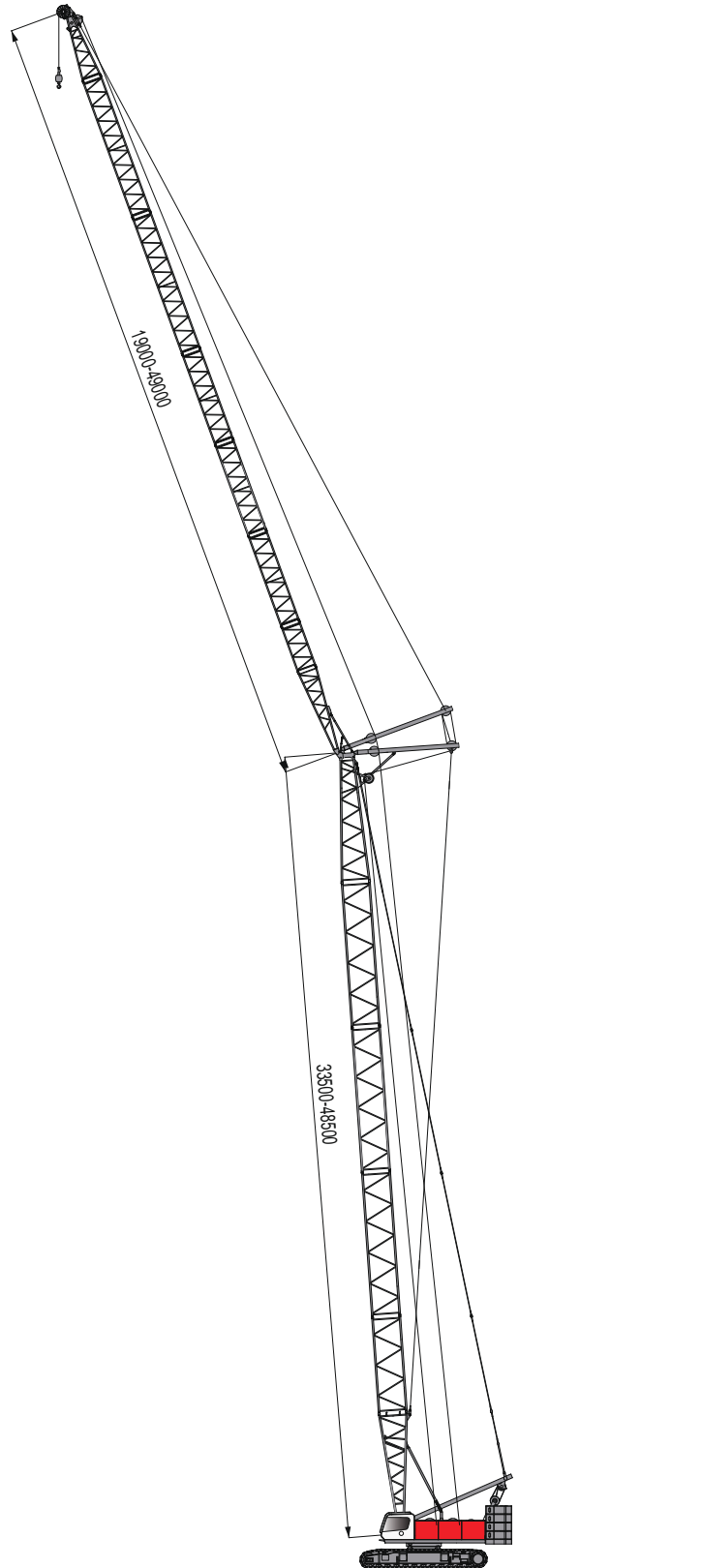



Technical Data



Items		Unit	Data	
Max.rated lifting capacity		t	135@5m	
Main boom length		m	18~75	
Fly jib length		m	13~31	
Main boom+ Fly jib max.length		m	63+31	
Main boom+ Luffing jib max.length		m	48.5+49	
Boom derricking angle		°	30~84	
Hook blocks		t	135/80/25/12.5	
Working speed	Rope speed	Main winch hoist, lower (rope dia.Φ26mm)	m/min	120
		Aux. winch hoist, lower (rope dia.Φ26mm)	m/min	120
		Boom hoist, lower (rope dia.Φ22mm)	m/min	48
	Swing speed		r/min	2.7
	Travel speed		km/h	0-0.78/0-1.15
Reevings			12	
Single line pull		t	12.5	
Gradeability		%	30	
Engine		kW/r/min	209/2000 (export) 225/2000(domestic)	
Swing radius		mm	5530	
Transport dimension		mm	13680×3300×3330	
Crane mass(with basic boom, 135t hook)		t	130	
Ground bearing pressure		MPa	0.08	
Counterweight		t	54	



Specifications

Engine

Cummins QSL9 EU3 emission, direct injection, water cooled, 209kW(280HP) at 2000rpm, 24V voltage.
 Dong Feng Cummins 6LTAA8.9, National II emission, 225kW(300HP) at 2000rpm.

Hydraulic system

Rexroth main pump: main power adjustment, at the same the load feedback function can be realized. Have the function of micro-speed.
 Domestic main pump: main power adjustment, at the same the load feedback function can be realized.
 The hand grip control meets the ISO standard, Max. control pressure: 320bar
 Hydraulic oil tank capacity: 500L

Swing system

Inner gearing swing drive, independent closed swing system, 360°rotation.
 Swing locking: hydraulically swing locking, ensure to lock the upper structure when finish the operation and during the transportation.
 Swing float: make sure the boom center and gravity of load be in the same plane. To avoid wiggle happens after lifting the load.
 Brake: automatic brake mode; spring applied, hydraulically released disc brakes. Swing speed:

Upper structure

Extreme durable and lean design, fully computer aided designed and optimized.
 Made of high grade steel for long life time. All components are well organized mounted
 In the spacious engine and hydraulic compartments.
 Excellent access by large doors for easy maintenance.
 Cover top plates made of aluminum to offer anti-skid safety and resist sun and rain.
 Counterweight: 54t

Electric system

24Volt system with comprehensive layout and high grade wiring.
 Premium quality connectors and switches for best safety and reliability.
 Well organized electric switch board in sliding box for easy maintenance.
 Canbus monitoring system of engine and moment limiter are as option available.

Main winch1&2

Each winch is driven independently by a hydraulic piston motor.
 Each motor is equipped with counterbalance valves to provide controlled load lowering and prevent accidental load drop if the hydraulic pressure is suddenly lost.
 Automatic brake mode, spring applied, hydraulically released, multiple-disc type brake.
 Drum: line type drum, to ensure no rope disorder even when more layers.

Winch 1 & 2

Single line pull	12.54t
Rope diameter	26 mm
Line speed	0~120m/min

Derricking winch

Driven independently by a hydraulic piston motor provided with counterbalance valves.
 Automatic brake mode, spring applied, hydraulically released, disc type brake.
 Mechanical drum pawl lock supplies full orientation brake.

Derricking winch

Single line pull	10 t
Rope diameter	22 mm
Line speed	48 m/min

Undercarriage

Each track is independently driven by a hydraulic piston motor. Spring loaded hydraulically releasable, automatic type, disc brake.
 Traveling speed: 0~1.33km/h



Machine Configuration



Main boom

Max.lifting capacity:135t x 5m

Max.boom length: 75m

Runner

Max.lifting capacity:12t x 16m

Max.boom length: 63m

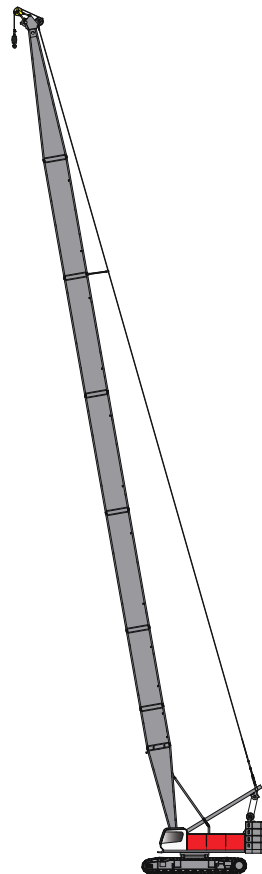
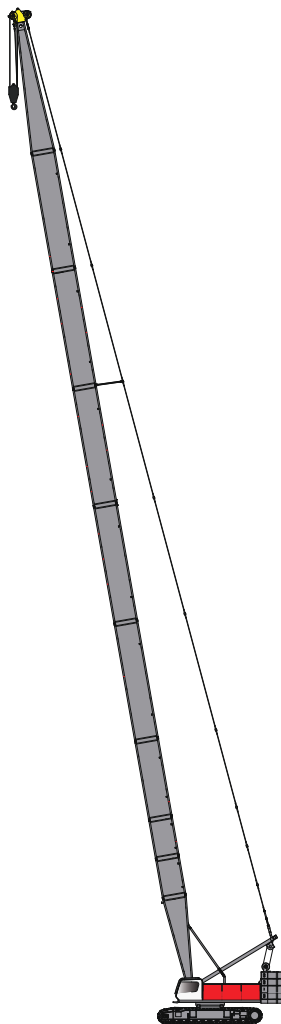



Machine Configuration



Fly jib



Max.lifting capacity: 14.6t x 14m
Max.boom length: 63m+31m

Luffing jib



Max.lifting capacity: 34t x 12m
Max.boom length: 48.5m+49m

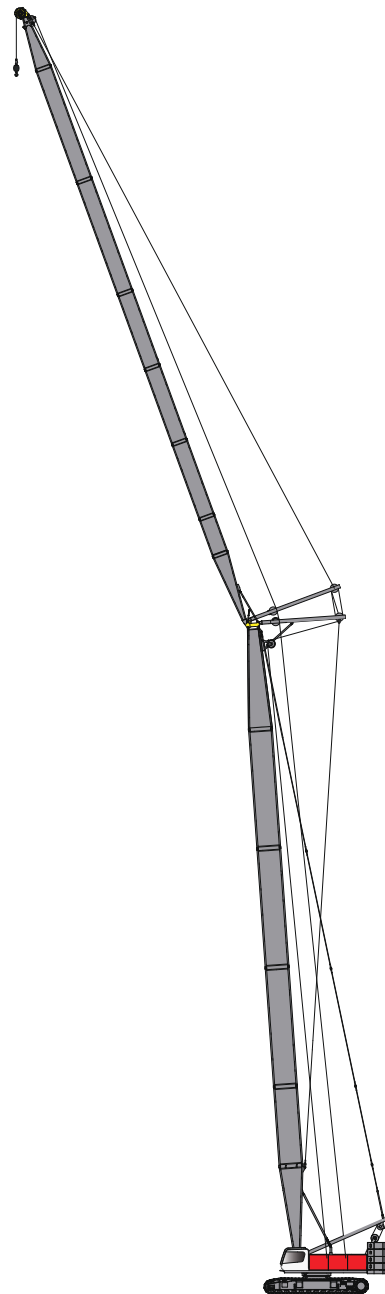
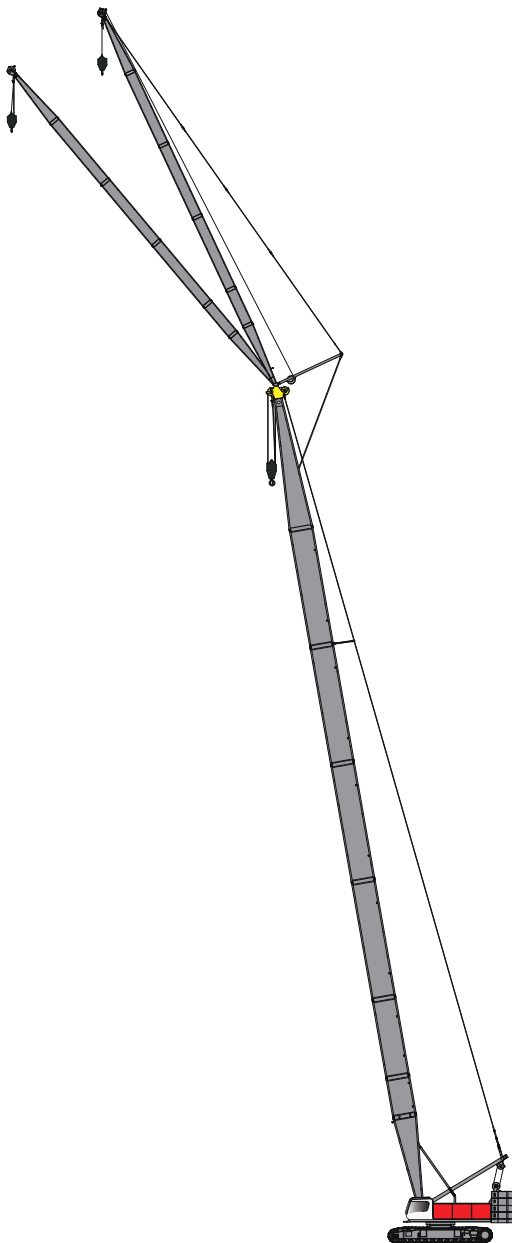



Notes for Load Chart

- 1. Ratings according to GB3811, ISO4302 and ISO4305.
- 2. The rated loads shown are based on the machine on firm level ground.
- 3. The rated loads shown are in metric tons , base on 75% of tipping load; and rear stability coefficient is not less than 1.15.
- 4.The user must deduct or limit the loads to allow for difficult conditions such as soft or uneven ground, out of level conditions, wind, side loads, pendulum action, jerking traveling or sudden stopping of loads. Weight of hook and slings should be deducted from the load chart (as shown below).
- 5.When mounted with runner or fly jib, the actual lifting capacity is the rated load deducting the weights of main and auxiliary hooks+runner or fly jib(shown in the table below). The crane can not work if the capacity deducted is less than 0.8t.
- 6. When mounted with runner, length of boom is 18~63m; when mounted with fly jib, length of boom is 39~63m; when mounted with derricking jib, length of boom is 33.5~48.5m.
- 7. Counterweight: 54t.
- 8.The radius in chat is actual working radius after lifting.
- 9. The lifting capacities below are for reference only. For actual lifting capacities please refer to the load chart in operator’s cab or manual.

Jib length (m)	13	19	25	31	Runner
Weight (t)	1.5	1.7	1.9	2.1	0.2

Hook	Reevings Self-weight (t)	Reevings and max.lifting capacity (t)											
		12	11	10	9	8	7	6	5	4	3	2	1
135t	2.809	120	110	100	90	80	70	60	50	40	30	20	10
80t	1.030					80	70	60	50	40	30	20	10
25t	0.435											20	10
12.5t	0.328												10

Depending on classification of hoist cable according to data above.



Working Range - Main Boom

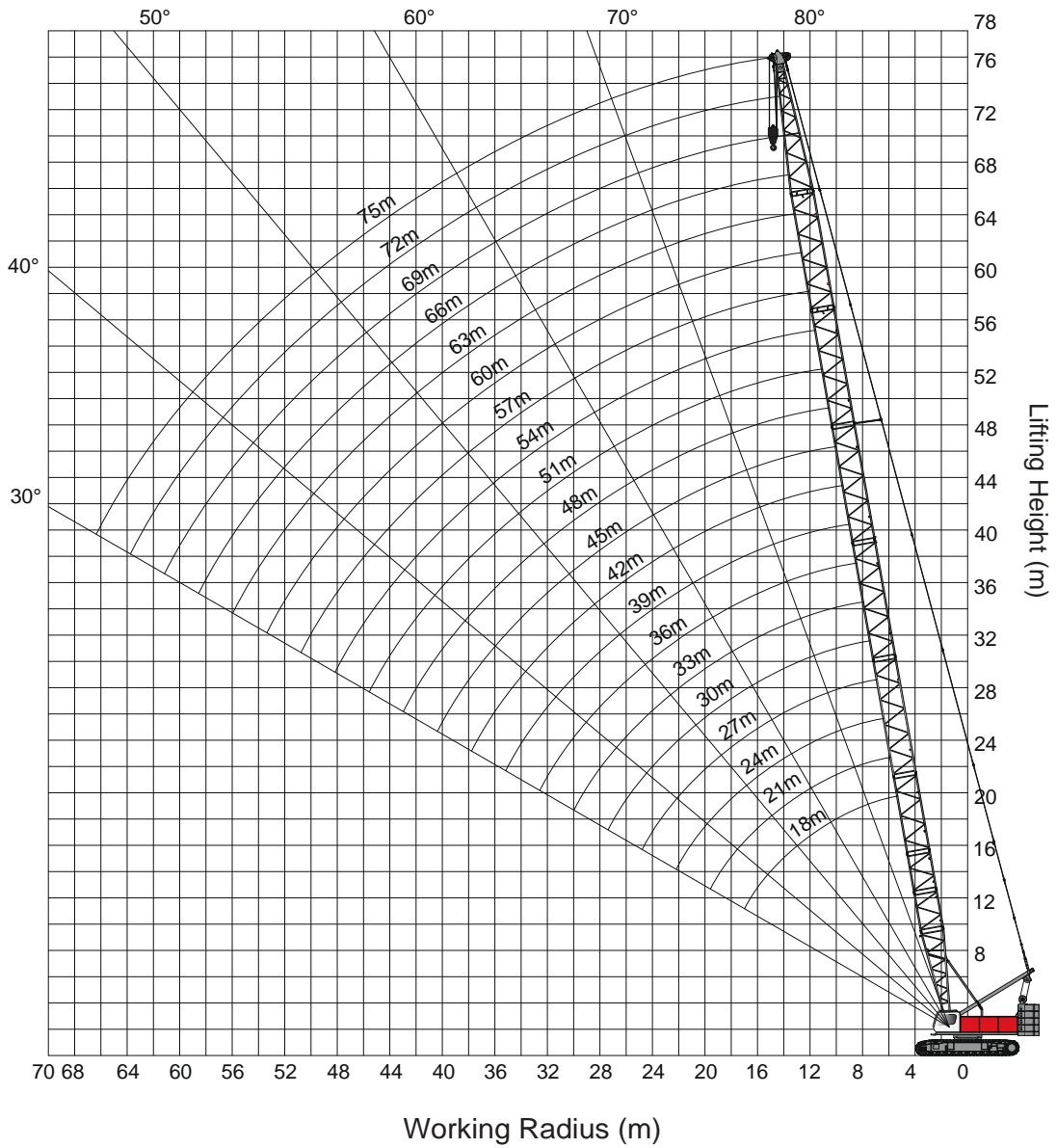



Main Boom Load Chart



18m-75m

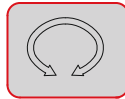

360°

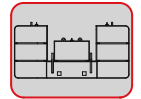

54t

Unit: t

Length(m) Radius(m)	18.0m	24.0m	30.0m	36.0m	42.0m	48.0m	54.0m	60.0m	66.0m	72.0m	75.0m
4.0m	135/4.92										
5.0m	135.0	120/5.96									
6.0m	120.0	120.0									
7.0m	110.0	109.0	90.0								
8.0m	88.9	89.0	90.0	78/8.05							
9.0m	78.0	75.6	88.6	72.6	66.5/9.09						
10.0m	67.5	65.5	63.2	63.1	61.8	56/10.1	45/11.2				
12.0m	51.8	51.7	50.3	48.6	48.4	48.1	45.0	36/12.2	29/13.3		
14.0m	41.7	41.9	41.5	40.2	39.1	38.8	38.6	36.0	29.0	21.4/14.3	
16.0m	34.8	34.9	34.8	33.9	33.1	33.0	32.7	31.8	29.0	20.6	18.2
18.0m	30.16/17.2	29.8	29.7	29.3	28.6	28.4	28.3	27.0	26.8	19.6	17.4
20.0m		25.9	25.8	25.4	25.0	24.8	24.6	23.7	23.0	18.7	16.5
22.0m		22.8	22.7	22.3	22.2	21.8	21.6	21.0	20.6	18.0	15.8
24.0m		21.25/22.4	20.2	19.8	19.6	19.3	19.0	18.5	18.2	17.5	15.1
26.0m			18.0	17.7	17.6	17.2	16.9	16.4	16.2	15.6	14.4
28.0m			15.83/27.6	15.9	15.8	15.4	15.2	14.7	14.6	14.0	13.5
30.0m				14.4	14.3	13.9	13.5	13.0	13.0	12.6	12.2
32.0m				13.0	12.9	12.5	12.4	12.0	11.7	11.4	11.0
34.0m				12.32/32.8	11.8	11.4	11.2	10.8	10.6	10.3	9.9
36.0m					10.8	10.5	10.3	9.8	9.5	9.2	8.8
38.0m					9.9	9.5	9.4	9.0	8.7	8.3	8.0
40.0m						8.7	8.6	8.2	7.9	7.5	7.3
42.0m						8.0	7.9	7.4	7.3	7.0	6.5
44.0m						7.587/43.2	7.3	6.9	6.5	6.2	6.0
46.0m							6.5	6.3	6.0	5.7	5.4
48.0m							6.0	5.8	5.6	5.2	4.9
50.0m							5.954/48.4	5.3	5.0	4.8	4.5
52.0m								4.9	4.6	4.4	4.1
54.0m								4.575/53.6	4.3	4.0	3.7
56.0m									3.9	3.6	3.3
58.0m									3.6	3.3	3.1
60.0m									3.3/58.8	2.9	2.7
62.0m										2.7	2.4
64.0m										2.4	2.1



Working Range - Runner

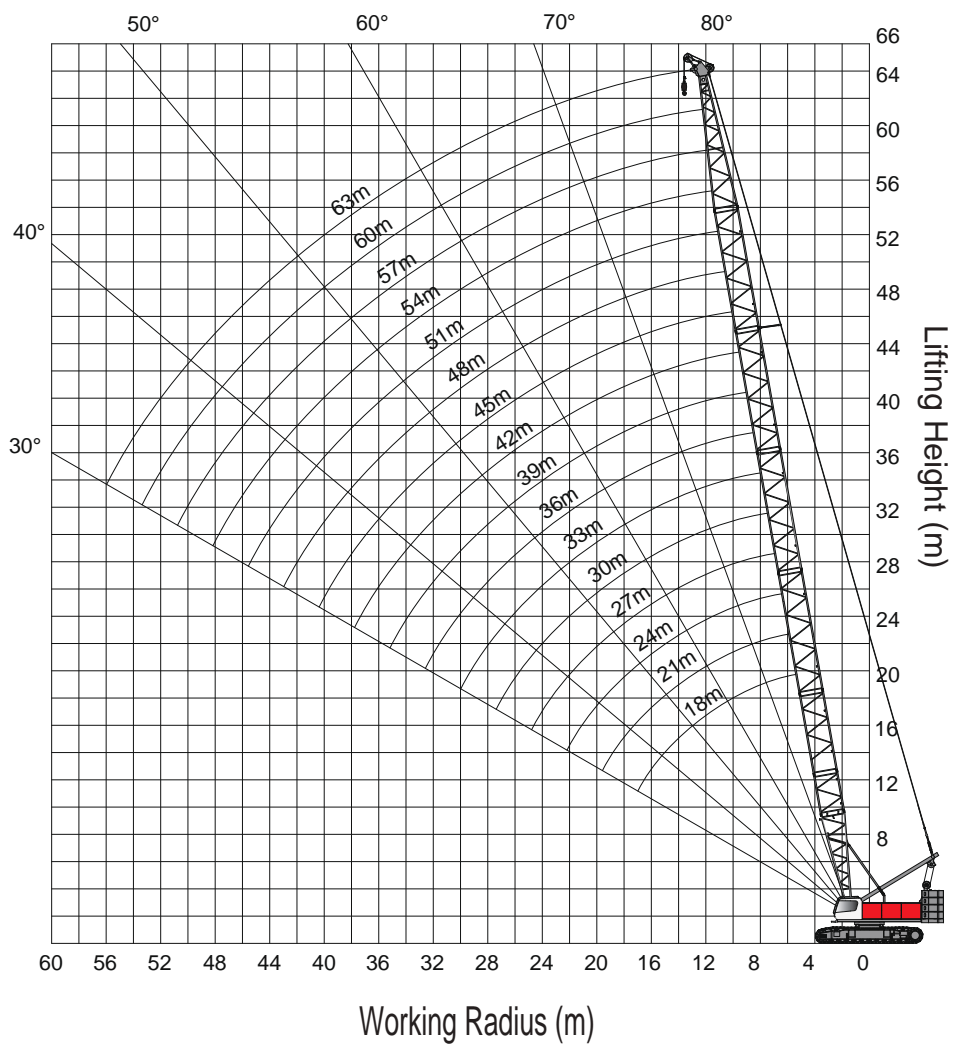



Runner Load Chart

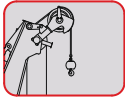

25m-61m

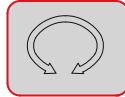

360°

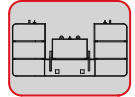

54t

Unit: t

Length(m) Radius(m)	25.0m	28.0m	31.0m	34.0m	37.0m	40.0m	43.0m	46.0m	49.0m	52.0m	55.0m	58.0m	61.0m
6.0m	6.7×9.0												
7.0m	9.0	7.3×9.0	7.9×9.0										
8.0m	9.0	9.0	9.0	8.4×9.0	8.9×9.0								
9.0m	9.0	9.0	9.0	9.0	9.0	9.7×9.0	9.9×9.0						
10.0m	9.0	9.0	9.0	9.0	9.0	9.0	9.0	10.4×9.0	11.0×9.0	11.7×9.0			
12.0m	9.0	9.0	9.0	9.0	9.0	9.0	9.0	9.0	9.0	9.0	12.2×9.0	12.7×9.0	13.0×9.0
14.0m	9.0	9.0	9.0	9.0	9.0	9.0	9.0	9.0	9.0	9.0	9.0	9.0	9.0
16.0m	9.0	9.0	9.0	9.0	9.0	9.0	9.0	9.0	9.0	9.0	9.0	9.0	9.0
18.0m	9.0	9.0	9.0	9.0	9.0	9.0	9.0	9.0	9.0	9.0	9.0	9.0	9.0
20.0m	9.0	9.0	9.0	9.0	9.0	9.0	9.0	9.0	9.0	9.0	9.0	9.0	9.0
22.0m	9.0	9.0	9.0	9.0	9.0	9.0	9.0	9.0	9.0	9.0	9.0	9.0	9.0
24.0m	9.0	9.0	9.0	9.0	9.0	9.0	9.0	9.0	9.0	9.0	9.0	9.0	9.0
26.0m	24.6×9.0	9.0	9.0	9.0	9.0	9.0	9.0	25.8×9.0	25.6×9.0	25.3×9.0	25.1×9.0	25.1×9.0	24.8×9.0
28.0m	27.2×8.7		26.8×9.0	26.7×9.0	26.3×9.0	26.2×9.0	8.0	7.9	7.7	7.6	7.5	7.5	7.4
30.0m			29.8×7.7	7.6	7.3	7.2	7.2	7.0	6.9	6.8	6.6	6.6	6.5
32.0m			6.7		6.6	6.5	6.4	6.3	6.2	6.1	5.9	5.9	5.8
34.0m			32.4×6.6		6.0	5.9	5.8	5.7	5.5	5.5	5.3	5.3	5.2
36.0m					35.0×5.7	5.4	5.3	5.2	5.0	4.9	4.7	4.7	4.6
38.0m					37.6×5.0		4.8	4.7	4.5	4.4	4.2	4.2	4.1
40.0m							4.3	4.2	4.1	4.0	3.8	3.8	3.6
42.0m							40.2×4.2	3.8	3.7	3.6	3.4	3.3	3.2
44.0m							42.8×3.7		3.4	3.2	3.0	2.9	2.8
46.0m									45.6×3.2	2.9	2.6	2.5	2.4
48.0m									2.4		2.3	2.2	2.1
50.0m											2.0	1.9	1.8
52.0m											50.6×1.8	1.6	1.5



Working Range - Fly Jib

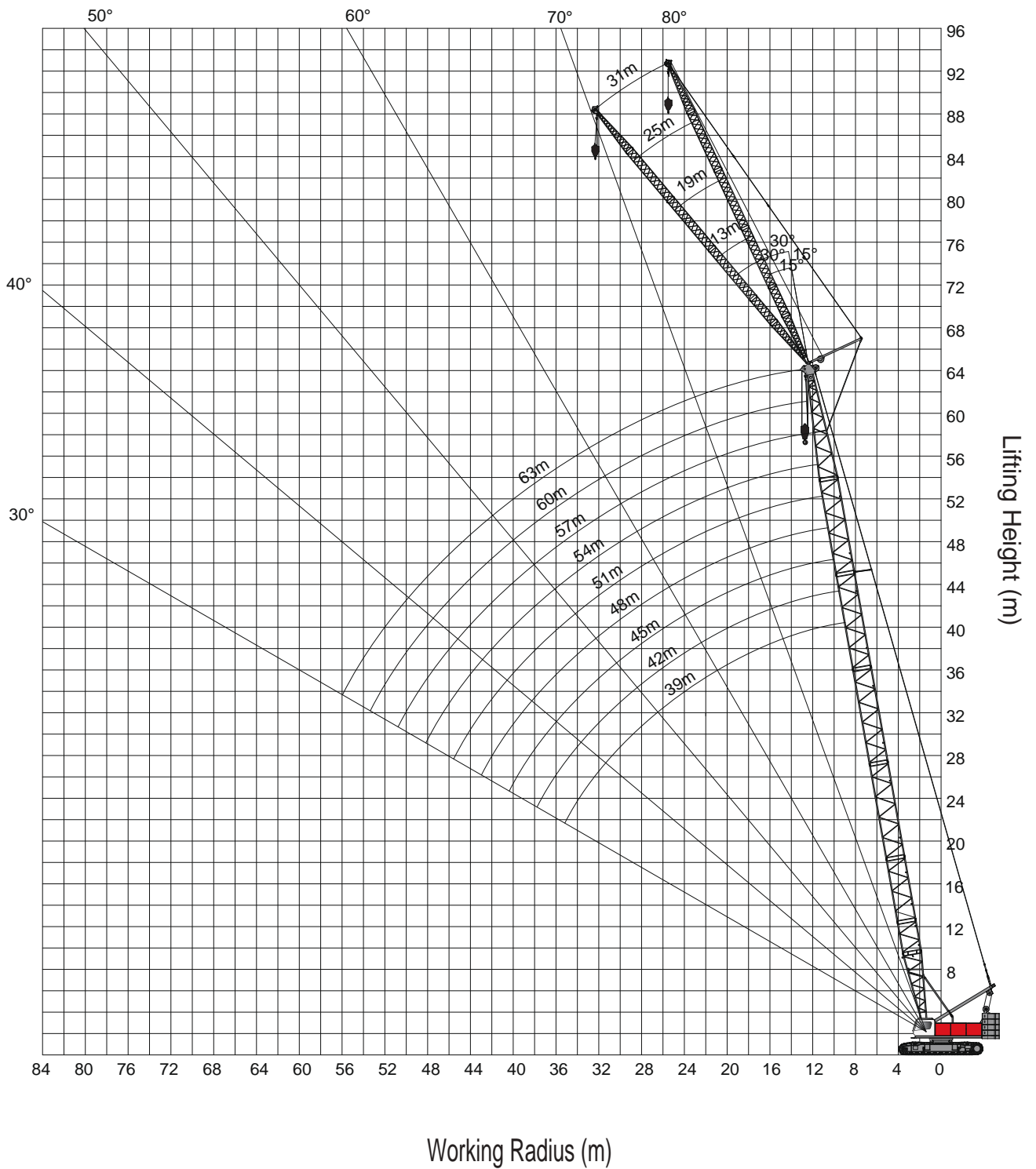



Fly Jib Load Chart



39m-63m

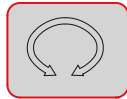

360°



15°/30°

13m-31m

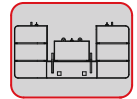

54t

Unit: t

Main boom length	39.0m								42.0m								
	13.0m		19.0m		25.0m		31.0m		13.0m		19.0m		25.0m		31.0m		
	15°	30°	15°	30°	15°	30°	15°	30°	15°	30°	15°	30°	15°	30°	15°	30°	
14.0m	14.6																
16.0m	14.3								14.4								
18.0m	14.1	11.5	9.0						14.2	11.6	9.1						
20.0m	13.9	10.9	8.9		5.5				14.0	11.1	8.9		5.6				
22.0m	13.7	10.5	8.7	7.5	5.4		3.2		13.8	10.6	8.8	7.6	5.5		3.2		
24.0m	13.6	10.0	8.6	7.2	5.4		3.1		13.7	10.2	8.7	7.3	5.4		3.2		
26.0m	13.4	9.7	8.5	6.9	5.3	5.0	3.1		13.5	9.8	8.6	7.0	5.3	5.0	3.1		
28.0m	13.3	9.3	8.4	6.6	5.2	4.9	3.0		13.4	9.5	8.5	6.7	5.2	4.9	3.0		
30.0m	12.9	9.0	8.3	6.4	5.1	4.9	3.0	2.7	13.2	9.2	8.4	6.5	5.2	4.9	3.0	2.7	
32.0m	12.3	8.7	8.2	6.2	5.1	4.8	2.9	2.6	12.3	8.9	8.3	6.3	5.1	4.8	3.0	2.6	
34.0m	11.4	8.5	8.1	5.9	5.0	4.6	2.9	2.5	11.3	8.7	8.2	6.1	5.0	4.7	2.9	2.5	
36.0m	10.5	8.2	8.0	5.8	5.0	4.4	2.8	2.4	10.4	8.4	8.1	5.9	5.0	4.5	2.9	2.4	
38.0m	9.7	8.0	7.8	5.6	4.9	4.3	2.8	2.3	9.6	8.2	8.0	5.7	4.9	4.4	2.8	2.3	
40.0m	9.0	7.9	7.5	5.4	4.8	4.1	2.7	2.2	8.8	8.0	7.8	5.5	4.9	4.2	2.8	2.2	
42.0m	8.3	7.7	7.2	5.3	4.8	4.0	2.6	2.1	8.2	7.9	7.5	5.4	4.8	4.1	2.7	2.2	
44.0m	7.7	7.6	7.0	5.2	4.7	3.9	2.5	2.0	7.6	7.7	7.2	5.3	4.8	4.0	2.5	2.1	
46.0m	7.2	7.3	6.7	5.1	4.5	3.8	2.3	2.0	7.1	7.2	7.0	5.2	4.7	3.9	2.4	2.0	
48.0m	6.7	6.7	6.5	5.0	4.4	3.7	2.2	1.9	6.6	6.7	6.7	5.1	4.5	3.8	2.3	1.9	
50.0m			6.3	4.9	4.3	3.6	2.2	1.8	6.1	6.2	6.4	5.0	4.4	3.7	2.2	1.9	
52.0m			6.1	4.8	4.2	3.5	2.1	1.8			6.0	4.9	4.3	3.6	2.1	1.8	
54.0m				4.8	4.1	3.5	2.0	1.7			5.6	4.8	4.2	3.5	2.1	1.8	
56.0m					4.0	3.4	1.9	1.7			5.3	4.8	4.1	3.5	2.0	1.7	
58.0m					3.9	3.4	1.8	1.6					4.0	3.4	1.9	1.7	
60.0m						3.3	1.8	1.6					4.0	3.4	1.8	1.6	
62.0m							1.7	1.6					3.9	3.3	1.8	1.6	
64.0m							1.7	1.6							1.7	1.6	
66.0m								1.6								1.7	1.6
70.0m																	



Fly Jib Load Chart



39m-63m

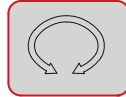

360°



15°/30°

13m-31m

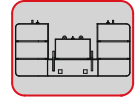

54t

Unit: t

Main boom length	45.0m								48.0m								
	13.0m		19.0m		25.0m		31.0m		13.0m		19.0m		25.0m		31.0m		
	15°	30°	15°	30°	15°	30°	15°	30°	15°	30°	15°	30°	15°	30°	15°	30°	
14.0m																	
16.0m	14.5								14.5								
18.0m	14.3	11.8	9.1						14.3	9.1							
20.0m	14.1	11.3	9.0		5.6				14.2	11.4	9.0						
22.0m	13.9	10.8	8.8	7.7	5.5				14.0	11.0	8.9		5.5				
24.0m	13.7	10.4	8.7	7.4	5.4		3.2		13.8	10.6	8.8	7.5	5.4		3.2		
26.0m	13.6	10.0	8.6	7.1	5.3	5.0	3.1		13.7	10.2	8.7	7.2	5.4	5.0	3.1		
28.0m	13.5	9.7	8.5	6.9	5.3	4.9	3.1		13.5	9.9	8.6	7.0	5.3	5.0	3.1		
30.0m	13.2	9.4	8.4	6.6	5.2	4.9	3.0	2.8	12.9	9.5	8.5	6.7	5.2	4.9	3.0	2.8	
32.0m	12.1	9.1	8.3	6.4	5.1	4.9	3.0	2.7	11.9	9.3	8.4	6.5	5.2	4.9	3.0	2.7	
34.0m	11.1	8.8	8.2	6.2	5.1	4.8	2.9	2.6	10.9	9.0	8.3	6.3	5.1	4.8	3.0	2.6	
36.0m	10.2	8.6	8.2	6.0	5.0	4.6	2.9	2.5	10.0	8.8	8.2	6.1	5.1	4.7	2.9	2.5	
38.0m	9.3	8.4	8.1	5.8	5.0	4.4	2.9	2.4	9.1	8.5	8.1	5.9	5.0	4.5	2.9	2.4	
40.0m	8.6	8.2	8.0	5.7	4.9	4.3	2.8	2.3	8.4	8.3	8.1	5.8	5.0	4.4	2.8	2.3	
42.0m	8.0	8.0	7.7	5.5	4.9	4.2	2.7	2.2	7.8	8.0	8.0	5.6	4.9	4.3	2.8	2.2	
44.0m	7.4	7.6	7.4	5.4	4.8	4.1	2.6	2.1	7.2	7.4	7.5	5.5	4.9	4.1	2.7	2.2	
46.0m	6.8	7.0	7.2	5.3	4.8	4.0	2.5	2.1	6.6	6.9	7.0	5.4	4.8	4.0	2.6	2.1	
48.0m	6.3	6.5	6.7	5.2	4.6	3.9	2.4	2.0	6.1	6.3	6.5	5.3	4.8	3.9	2.5	2.0	
50.0m	5.9	6.0	6.2	5.1	4.5	3.8	2.3	1.9	5.7	5.8	6.0	5.1	4.6	3.8	2.4	2.0	
52.0m	5.5	5.6	5.8	5.0	4.4	3.7	2.2	1.9	5.3	5.4	5.6	5.1	4.5	3.7	2.3	1.9	
54.0m			5.4	4.9	4.3	3.6	2.1	1.8	4.9	5.0	5.2	5.0	4.4	3.7	2.2	1.9	
56.0m			5.0	4.8	4.2	3.5	2.1	1.8	4.6		4.8	4.9	4.3	3.6	2.1	1.8	
58.0m			4.7	4.8	4.1	3.5	2.0	1.7			4.5	4.7	4.2	3.5	2.1	1.8	
60.0m					4.0	3.4	1.9	1.7			4.2	4.3	4.1	3.5	2.0	1.7	
62.0m					4.0	3.4	1.8	1.6			4.0		4.1	3.4	1.9	1.7	
64.0m					3.9	3.3	1.8	1.6					3.9	3.4	1.8	1.6	
66.0m							1.7	1.6					3.6	3.3	1.8	1.6	
70.0m							1.6	1.6							1.7	1.6	
74.0m															1.6		
78.0m																	



Fly Jib Load Chart



39m-63m

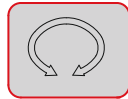

360°



15°/30°

13m-31m

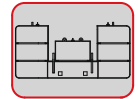

54t

Unit: t

Main boom length	51.0m								54.0m															
	13.0m		19.0m		25.0m		31.0m		13.0m		19.0m		25.0m		31.0m									
Fly jib length Fly jib angle	15°	30°	15°	30°	15°	30°	15°	30°	15°	30°	15°	30°	15°	30°	15°	30°								
14.0m																								
16.0m	14.6																							
18.0m	14.4																							
20.0m	14.2	11.6	9.0																					
22.0m	14.1	11.1	8.9		5.5				14.1	11.3	9.0		5.6											
24.0m	13.9	10.7	8.8		7.6		5.5		3.2		14.0	10.9	8.9		7.7		5.5		3.2					
26.0m	13.8	10.4	8.7		7.3		5.4		3.1		13.8	10.5	8.8		7.4		5.4		3.2					
28.0m	13.6	10.0	8.6		7.1		5.3		5.0		13.7	10.2	8.7		7.1		5.4		5.0		3.1			
30.0m	12.8	9.7	8.5		6.8		5.3		4.9		12.6	9.9	8.6		6.9		5.3		4.9		3.1			
32.0m	11.7	9.4	8.4		6.6		5.2		4.9		11.5	9.6	8.5		6.7		5.2		4.9		3.0		2.8	
34.0m	10.7	9.2	8.3		6.4		5.1		4.8		10.5	9.3	8.4		6.5		5.2		4.9		3.0		2.7	
36.0m	9.8	8.9	8.3		6.2		5.1		4.7		9.6	9.1	8.3		6.3		5.1		4.8		2.9		2.6	
38.0m	9.0	8.7	8.2		6.0		5.0		4.6		8.8	8.9	8.2		6.1		5.1		4.7		2.9		2.5	
40.0m	8.3	8.5	8.1		5.9		5.0		4.5		8.1	8.3	8.2		6.0		5.0		4.5		2.9		2.4	
42.0m	7.6	7.9	7.9		5.7		4.9		4.3		7.4	7.7	7.7		5.8		5.0		4.4		2.8		2.3	
44.0m	7.0	7.3	7.4		5.6		4.9		4.2		6.8	7.2	7.2		5.7		4.9		4.3		2.8		2.2	
46.0m	6.5	6.8	6.8		5.5		4.9		4.1		6.3	6.6	6.6		5.6		4.9		4.2		2.7		2.2	
48.0m	6.0	6.2	6.3		5.3		4.8		4.0		5.8	6.1	6.1		5.4		4.8		4.1		2.6		2.1	
50.0m	5.6	5.8	5.9		5.2		4.7		3.9		5.4	5.6	5.7		5.3		4.8		4.0		2.5		2.0	
52.0m	5.1	5.3	5.5		5.1		4.6		3.8		4.9	5.1	5.3		5.2		4.7		3.9		2.4		2.0	
54.0m	4.8	4.9	5.1		5.1		4.5		3.7		4.6	4.7	4.9		5.1		4.6		3.8		2.4		1.9	
56.0m	4.4	4.5	4.7		5.0		4.4		3.7		4.2	4.3	4.5		4.8		4.5		3.7		2.3		1.9	
58.0m	4.1	4.1	4.4		4.6		4.3		3.6		3.9	4.0	4.2		4.4		4.4		3.7		2.2		1.8	
60.0m			4.1		4.2		4.2		3.5		3.5	3.6	3.9		4.1		4.1		3.6		2.1		1.8	
62.0m			3.8		3.9		4.0		3.5				3.6		3.7		3.8		3.5		2.0		1.7	
64.0m			3.5		3.6		3.8		3.4				3.3		3.4		3.6		3.5		2.0		1.7	
66.0m							3.5		3.4				3.0		3.1		3.3		3.4		1.9		1.7	
70.0m							3.0		3.1								2.8		3.0		1.8		1.6	
74.0m																					1.7		1.6	
78.0m																					1.6		1.6	



Fly Jib Load Chart



39m-63m

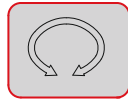

360°



15°/30°

13m-31m

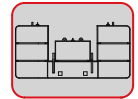

54t

Unit: t

Main boom length	57.0m								60.0m							
	13.0m		19.0m		25.0m		31.0m		13.0m		19.0m		25.0m		31.0m	
Fly jib length Fly jib angle	15°	30°	15°	30°	15°	30°	15°	30°	15°	30°	15°	30°	15°	30°	15°	30°
14.0m																
16.0m																
18.0m	14.5								14.6							
20.0m	14.3	11.8	9.1						14.4		9.1					
22.0m	14.2	11.4	9.0		5.6				14.2	11.5	9.0					
24.0m	14.0	11.0	8.9	7.8	5.5				14.1	11.1	8.9		5.5			
26.0m	13.9	10.6	8.8	7.5	5.4		3.2		13.9	10.8	8.8	7.6	5.5		3.2	
28.0m	13.6	10.3	8.7	7.2	5.4	5.0	3.1		13.4	10.5	8.7	7.3	5.4	5.0	3.1	
30.0m	12.4	10.0	8.6	7.0	5.3	5.0	3.1		12.2	10.2	8.6	7.1	5.3	5.0	3.1	
32.0m	11.3	9.7	8.5	6.8	5.3	4.9	3.0	2.8	11.1	9.9	8.6	6.9	5.3	4.9	3.1	2.8
34.0m	10.3	9.5	8.4	6.6	5.2	4.9	3.0	2.7	10.2	9.6	8.5	6.7	5.2	4.9	3.0	2.7
36.0m	9.4	9.2	8.4	6.4	5.1	4.8	3.0	2.6	9.3	9.4	8.4	6.5	5.2	4.9	3.0	2.6
38.0m	8.6	8.8	8.3	6.2	5.1	4.7	2.9	2.5	8.5	8.7	8.3	6.3	5.1	4.8	2.9	2.5
40.0m	7.9	8.1	8.2	6.1	5.0	4.6	2.9	2.4	7.7	8.0	8.1	6.2	5.1	4.7	2.9	2.5
42.0m	7.2	7.5	7.5	5.9	5.0	4.5	2.9	2.4	7.1	7.4	7.4	6.0	5.0	4.5	2.9	2.4
44.0m	6.6	7.0	7.0	5.8	5.0	4.4	2.8	2.3	6.5	6.9	6.8	5.9	5.0	4.4	2.8	2.3
46.0m	6.1	6.4	6.4	5.7	4.9	4.2	2.8	2.2	6.0	6.3	6.3	5.7	4.9	4.3	2.8	2.3
48.0m	5.6	5.9	5.9	5.5	4.9	4.1	2.7	2.1	5.5	5.8	5.8	5.6	4.9	4.2	2.8	2.2
50.0m	5.1	5.4	5.5	5.4	4.8	4.0	2.6	2.1	5.0	5.3	5.3	5.5	4.9	4.1	2.7	2.1
52.0m	4.7	4.9	5.0	5.3	4.8	4.0	2.5	2.0	4.6	4.8	4.9	5.3	4.8	4.0	2.6	2.1
54.0m	4.3	4.5	4.7	5.0	4.7	3.9	2.4	2.0	4.2	4.4	4.5	4.9	4.8	3.9	2.5	2.0
56.0m	4.0	4.1	4.3	4.6	4.6	3.8	2.3	1.9	3.9	4.0	4.2	4.5	4.4	3.9	2.4	2.0
58.0m	3.7	3.8	4.0	4.3	4.2	3.7	2.3	1.9	3.5	3.7	3.8	4.2	4.1	3.8	2.3	1.9
60.0m	3.3	3.4	3.7	3.9	3.9	3.6	2.2	1.8	3.2	3.3	3.5	3.8	3.8	3.7	2.2	1.9
62.0m	3.0	3.1	3.4	3.6	3.6	3.6	2.1	1.8	2.9	3.0	3.2	3.5	3.5	3.6	2.2	1.8
64.0m		2.8	3.1	3.3	3.3	3.5	2.0	1.7	2.6	2.7	2.9	3.2	3.2	3.6	2.1	1.8
66.0m			2.8	3.0	3.1	3.4	2.0	1.7	2.4	2.4	2.7	2.9	3.0	3.3	2.0	1.7
70.0m				2.4	2.6	2.8	1.9	1.6			2.2	2.3	2.5	2.7	1.9	1.7
74.0m					2.2	2.3	1.8	1.6					2.1	2.2	1.8	1.6
78.0m							1.7	1.6						1.8	1.7	1.6
82.0m								1.6								1.6
86.0m																



Fly Jib Load Chart



39m-63m

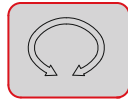

360°



15°/30°

13m-31m

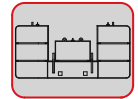

54t

Unit: t

Main boom length	63.0m											
	13.0m		19.0m		25.0m		31.0m					
Fly jib length Fly jib angle	15°	30°	15°	30°	15°	30°	15°	30°				
14.0m												
16.0m												
18.0m	14.6											
20.0m	14.4											
22.0m	14.3	11.6	9.1									
24.0m	14.1	11.2	9.0		5.5							
26.0m	14.0	10.9	8.9	7.6	5.5		3.2					
28.0m	13.2	10.6	8.8	7.4	5.4		3.2					
30.0m	12.0	10.3	8.7	7.2	5.4	5.0	3.1					
32.0m	10.9	10.0	8.6	7.0	5.3	4.9	3.1					
34.0m	10.0	9.8	8.5	6.8	5.3	4.9	3.0	2.7				
36.0m	9.1	9.3	8.4	6.6	5.2	4.9	3.0	2.7				
38.0m	8.3	8.5	8.4	6.4	5.2	4.8	3.0	2.6				
40.0m	7.5	7.8	7.9	6.3	5.1	4.7	2.9	2.5				
42.0m	6.9	7.2	7.2	6.1	5.1	4.6	2.9	2.4				
44.0m	6.3	6.7	6.6	6.0	5.0	4.5	2.9	2.4				
46.0m	5.7	6.1	6.1	5.8	5.0	4.4	2.8	2.3				
48.0m	5.3	5.6	5.6	5.7	4.9	4.3	2.8	2.2				
50.0m	4.8	5.1	5.1	5.6	4.9	4.2	2.7	2.2				
52.0m	4.4	4.7	4.7	5.2	4.9	4.1	2.6	2.1				
54.0m	4.0	4.2	4.3	4.7	4.6	4.0	2.6	2.0				
56.0m	3.6	3.9	4.0	4.4	4.2	3.9	2.5	2.0				
58.0m	3.3	3.5	3.6	4.0	3.9	3.8	2.4	1.9				
60.0m	3.0	3.2	3.3	3.6	3.6	3.8	2.3	1.9				
62.0m	2.7	2.8	3.0	3.3	3.3	3.7	2.2	1.9				
64.0m	2.4	2.5	2.7	3.0	3.0	3.4	2.2	1.8				
66.0m	2.2	2.3	2.5	2.7	2.8	3.1	2.1	1.8				
70.0m			2.0	2.2	2.3	2.6	2.0	1.7				
74.0m			1.6	1.7	1.9	2.1	1.9	1.6				
78.0m					1.5	1.6	1.7	1.6				
82.0m							1.4	1.6				
86.0m							1.0	1.2				



Working Range - Luffing Jib

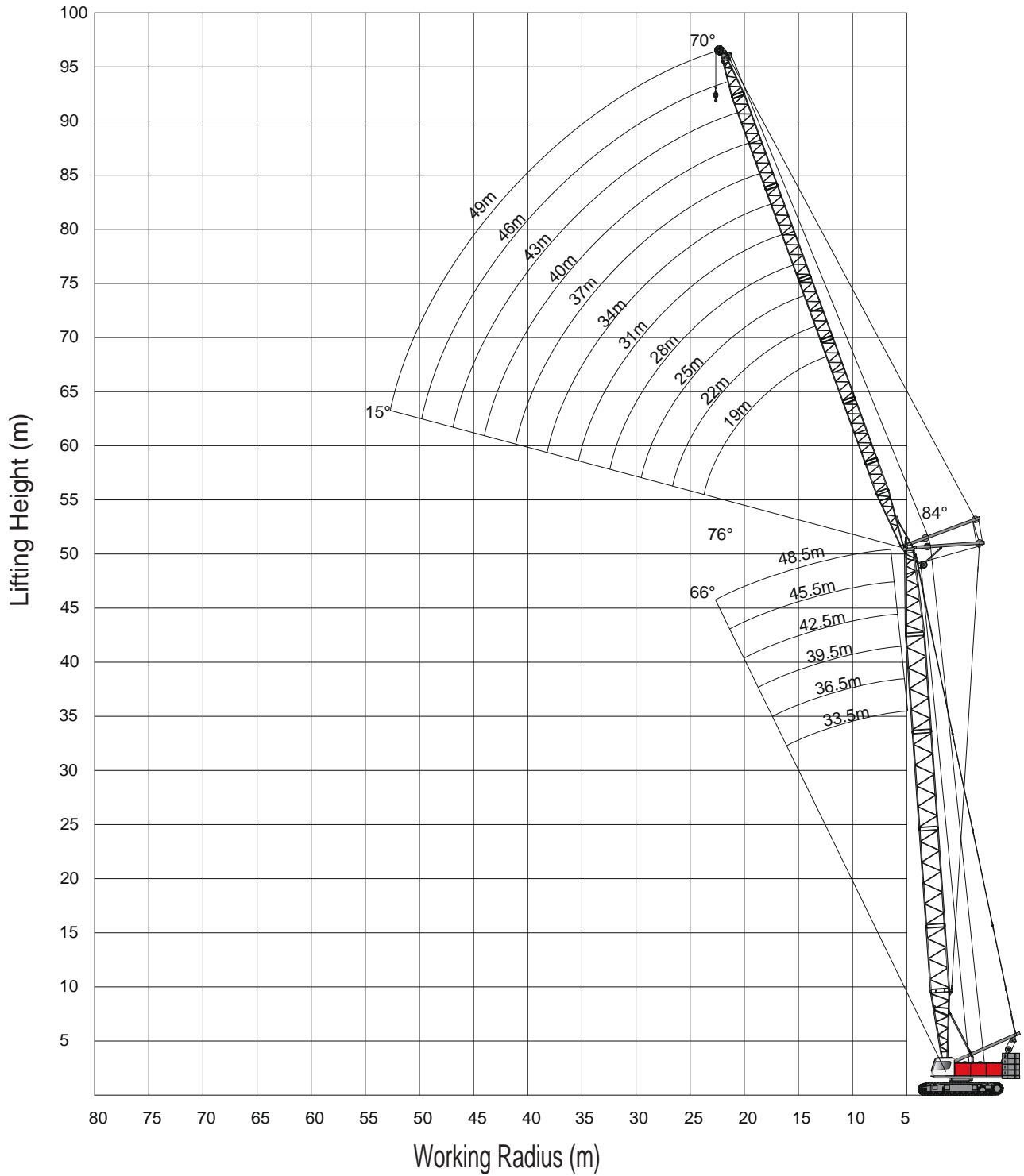



Luffing Jib Load Chart



33.5m-48.5m

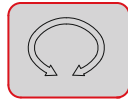

360°



19m-49m

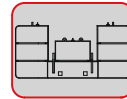

54t

Unit: t

Main boom length	33.5m																	
	19.0m			22.0m			25.0m			28.0m			31.0m			34.0m		
Luffing jib length Luffing jib angle	84.0°	76.0°	66.0°	84.0°	76.0°	66.0°	84.0°	76.0°	66.0°	84.0°	76.0°	66.0°	84.0°	76.0°	66.0°	84.0°	76.0°	66.0°
10.0m																		
12.0m																		
14.0m	34.0			34.0														
16.0m	30.4			30.0			29.6											
18.0m	26.7			26.3			26.0			23.0			23.0					
20.0m	23.8	22.1		23.5			23.1			22.8			22.5			22.2		
22.0m	21.4	19.9		21.1	19.6		20.9			20.5			20.3			20.0		
24.0m		18.1		19.2	17.9		18.9	17.6		18.7			18.4			18.1		
26.0m		16.6		17.6	16.3		17.3	16.1		17.1	15.8		16.8	15.5		16.6		
28.0m		15.2	13.8		15.0		16.0	14.8		15.7	14.5		15.5	14.3		15.3	14.1	
30.0m			12.7		13.8	12.5		13.6		14.5	13.4		14.3	13.2		14.1	13.0	
32.0m			11.7			11.5		12.6	11.3	13.4	12.4		13.3	12.2		13.1	12.0	
34.0m						10.7		11.7	10.5		11.5	10.2	12.3	11.3		12.1	11.1	
36.0m						10.0			9.8		10.7	9.5		10.5	9.3	11.3	10.3	
38.0m									9.1			8.9		9.8	8.7	10.4	9.6	8.5
40.0m												8.3		9.2	8.1		9.0	7.9
42.0m												7.8			7.6		8.4	7.4
44.0m															7.2			7.0
46.0m																		6.6
48.0m																		6.2



Luffing Jib Load Chart



33.5m-48.5m

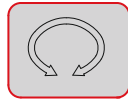

360°



19m-49m

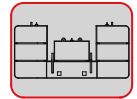

54t

Unit: t

Main boom length	33.5m																		
Luffing jib length	37.0m			40.0m			43.0m			46.0m			49.0m						
Luffing jib angle	84.0°	76.0°	66.0°	84.0°	76.0°	66.0°	84.0°	76.0°	66.0°	84.0°	76.0°	66.0°	84.0°	76.0°	66.0°				
10.0m																			
12.0m																			
14.0m																			
16.0m																			
18.0m																			
20.0m	20.2																		
22.0m	19.7			17.1			14.1												
24.0m	17.9			17.1			14.3			11.9									
26.0m	16.3			16.1			14.3			12.0			9.9						
28.0m	15.0			14.8			14.1			12.0			10.0						
30.0m	13.9	12.7		13.7			13.4			11.8			9.9						
32.0m	12.9	11.8		12.4	11.6		12.4	11.3		11.2			9.7						
34.0m	11.9	10.9		10.3	10.7		10.1	10.5		10.2	10.3		9.2						
36.0m	11.1	10.1		10.1	9.9		8.2	9.7		8.1	9.5		8.3	9.3					
38.0m	10.3	9.4		9.5	9.2		7.9	9.0		6.4	8.8		6.5	8.6					
40.0m	9.6	8.8	7.7	9.0	8.6		7.4	8.4		6.1	8.2		4.9	8.0					
42.0m	8.2		7.2	8.5	8.0	7.0	6.9	7.8		5.7	7.6		4.6	7.4					
44.0m	7.7		6.7	8.0	7.5	6.5	6.5	7.3	6.3	5.3	7.2		4.2	6.9					
46.0m			6.3	7.1		6.1	6.1	6.9	5.9	4.9	5.8	5.7	3.9	6.5					
48.0m			5.9	6.7		5.8	6.4		5.5	4.6	5.4	5.3	3.5	5.0	5.1				
50.0m			5.6			5.4	6.1		5.2	5.0		5.0	3.3	4.0	4.8				
52.0m						5.1			4.9	4.7		4.7	3.0	3.6	4.5				
54.0m				4.8			4.6			4.4		4.4	3.4		4.2				
56.0m							4.3					4.1	3.1		3.9				
58.0m												3.9			3.7				
60.0m												3.6			3.3				
62.0m															3.1				
64.0m																			



Luffing Jib Load Chart



33.5m-48.5m

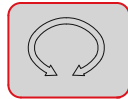

360°



19m-49m

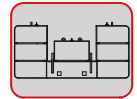

54t

Unit: t

Main boom length	36.5m																	
	19.0m			22.0m			25.0m			28.0m			31.0m			34.0m		
Luffing jib length																		
Luffing jib angle	84.0°	76.0°	66.0°	84.0°	76.0°	66.0°	84.0°	76.0°	66.0°	84.0°	76.0°	66.0°	84.0°	76.0°	66.0°	84.0°	76.0°	66.0°
10.0m																		
12.0m																		
14.0m	34.7																	
16.0m	30.0			29.6			23.0											
18.0m	26.4			26.1			23.0			23.0			23.0					
20.0m	23.5			23.2			22.9			22.5			22.2			22.0		
22.0m	21.2	19.5		3.0			2.6			2.3			20.0			19.8		
24.0m	19.4	17.8		19.1	17.5		18.7	17.2		18.5			18.2			17.9		
26.0m		16.3		17.4	16.3		17.2	15.8		16.9	15.5		16.7			16.5		
28.0m		15.0			14.8		15.8	14.5		15.5	14.2		15.3	14.0		15.2		
30.0m			12.3		13.6		14.6	13.4		14.4	13.2		14.2	12.9		14.0	12.7	
32.0m			11.4		12.6	11.2		12.4		13.3	12.2		13.2	12.0		13.0	11.8	
34.0m			1.6		1.4		11.5	1.2		11.3			12.2	11.9		12.5	1.9	
36.0m					9.7			9.5		1.5	9.3		1.3			11.2	1.1	
38.0m						9.4		8.8			8.6		9.6	8.4		1.5	9.4	
40.0m								8.3			8.4		9.0	7.8		8.8	7.6	
42.0m											7.5			7.4		8.3	7.2	
44.0m														7.0			6.7	
46.0m															6.5		6.3	
48.0m																	5.9	



Luffing Jib Load Chart



33.5m-48.5m

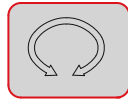

360°



19m-49m

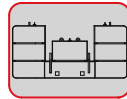

54t

Unit: t

Main boom length	36.5m																	
Luffing jib length	37.0m			4.0m			43.0m			46.0m			49.0m					
Luffing jib angle	84.0°	76.0°	66.0°	84.0°	76.0°	66.0°	84.0°	76.0°	66.0°	84.0°	76.0°	66.0°	84.0°	76.0°	66.0°	84.0°	76.0°	66.0°
10.0m																		
12.0m																		
14.0m																		
16.0m																		
18.0m																		
20.0m	2.2																	
22.0m	19.5			17.3														
24.0m	17.7			18.0			14.3			11.9								
26.0m	16.1			16.0			14.3			13.0			9.9					
28.0m	14.8			14.6			14.2			12.2			10.0					
30.0m	13.7	12.5		13.5			13.3			11.8			9.9					
32.0m	12.7	11.5		12.5	11.3		12.3			11.3			9.8					
34.0m	11.8	1.7		1.4	1.5		1.5	1.2		1.4			9.3					
36.0m	11.6	10.0		1.2	9.7		8.2	9.5		8.5	9.3		8.5	9.8				
38.0m	1.3	9.2		9.7	9.3		8.0	8.9		6.4	8.6		6.8	8.4				
40.0m	9.6	8.6		9.4	8.4		7.5	8.3		6.2	8.2		4.9	7.8				
42.0m		8.6	6.9	8.5	7.9		7.1	7.7		5.7	7.5		4.6	7.3				
44.0m		7.6	6.5	9.0	7.4	6.3	6.6	7.2		5.3	7.0		4.2	6.8				
46.0m		8.0	6.7		6.9	5.9	6.2	6.7	5.6	5.0	6.5		4.0	6.3				
48.0m			5.8		6.6	5.5		6.4	5.3	4.6	5.5	5.9	3.6	5.9				
50.0m			5.4			5.2		5.9	5.0	4.3	5.2	4.8	3.4	4.8	4.5			
52.0m			5.5			4.9		5.6	4.6		4.8	4.5	3.5	3.8	4.2			
54.0m						4.6			4.4		4.6	4.2		3.5	4.0			
56.0m									4.1			3.9		3.2	3.7			
58.0m									3.9			3.7		3.0	3.5			
60.0m												3.5			3.2			
62.0m															3.3			



Luffing Jib Load Chart



33.5m-48.5m

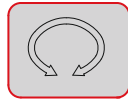

360°



19m-49m

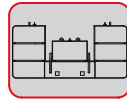

54t

Unit: t

Main boom length	39.5m																		
Luffing jib length	19.0m			22.0m			25.0m			28.0m			31.0m			34.0m			
Luffing jib angle	84.0°	76.0°	66.0°	84.0°	76.0°	66.0°	84.0°	76.0°	66.0°	84.0°	76.0°	66.0°	84.0°	76.0°	66.0°	84.0°	76.0°	66.0°	
10.0m																			
12.0m																			
14.0m	34.2																		
16.0m	29.6			23.0			23.0												
18.0m	26.3			23.0			23.0			23.0			23.0						
20.0m	23.2			22.9			22.6			22.3			22.0				21.7		
22.0m	2.9	19.1		2.7			2.4			2.6			19.8				19.5		
24.0m	19.8	17.4		18.8	17.1		18.5			18.2			18.0				17.7		
26.0m		15.9		17.2	15.7		17.0	15.4		16.7	15.1		16.5				16.2		
28.0m		14.7			14.5		15.6	14.3		15.4	13.9		15.2	13.7			14.9		
30.0m					13.4		14.5	13.2		14.2	12.9		14.2	12.7			13.9	12.4	
32.0m			2.0		12.3			12.2		13.2	11.9		13.4	11.7			12.8	11.5	
34.0m			1.2			2.0		11.3			11.5		12.1	1.9			12.0	1.7	
36.0m			9.5			9.3			9.1		1.3		11.3	1.2			11.1	9.9	
38.0m						8.7			8.5		9.6	8.3		9.4			1.4	9.2	
40.0m									8.0			7.7		8.8	7.5			8.6	
42.0m									7.5			7.2			7.5			8.9	6.9
44.0m												6.9			6.6			7.6	6.4
46.0m															6.2				6.3
48.0m															5.9				5.7
50.0m																			5.3
52.0m																			



Luffing Jib Load Chart



33.5m-48.5m

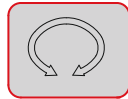

360°



19m-49m

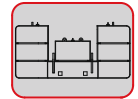

54t

Unit: t

Main boom length	39.5m															
Luffing jib length	37.0m			4.0m			43.0m			46.0m			49.0m			
Luffing jib angle	84.0°	76.0°	66.0°	84.0°	76.0°	66.0°	84.0°	76.0°	66.0°	84.0°	76.0°	66.0°	84.0°	76.0°	66.0°	
10.0m																
12.0m																
14.0m																
16.0m																
18.0m																
20.0m																
22.0m	19.2			17.0												
24.0m	17.4			17.8			11.5			11.5						
26.0m	15.9			15.7			11.5			11.5			9.9			
28.0m	14.7			14.4			11.5			11.5			9.9			
30.0m	13.6			13.3			11.5			11.5			10.0			
32.0m	12.6	11.3		12.4	11.6		11.5			11.4			9.8			
34.0m	11.7	1.4		1.4	1.2		2.0	1.1		1.6			9.5			
36.0m	1.9	9.7		1.2	9.5		8.2	9.3		8.9	9.7		8.6			
38.0m	1.2	9.2		9.7	8.8		8.8	8.6		6.5	8.4		7.2	8.2		
40.0m	9.6	8.4		9.1	8.2		7.6	8.9		6.3	7.8		4.9	7.6		
42.0m		7.9	6.6	8.6	7.7		7.7	7.5		5.9	7.3		4.7	7.7		
44.0m		7.4	6.2	8.2	7.3	6.0	6.6	7.0		5.4	6.8		4.3	6.6		
46.0m		6.9	5.8		6.8	5.6	6.2	6.6	5.4	5.3	6.4		4.0	6.2		
48.0m			5.4		6.4	5.2		6.1	5.6	4.7	5.7	4.8	3.6	5.8		
50.0m			5.1		6.0	4.9		5.8	4.7	4.4	5.3	4.5	3.4	4.2	4.3	
52.0m			4.8			4.6		5.4	4.4		4.9	4.2	3.9	3.9	4.0	
54.0m						4.4			4.1		4.6	3.9		3.6	3.7	
56.0m						4.9			3.9		4.3	3.7		3.3	3.5	
58.0m									3.6			3.5		3.3	3.2	
60.0m												3.2			3.1	
62.0m												3.3			2.8	



Luffing Jib Load Chart



33.5m-48.5m

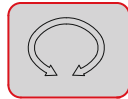

360°



19m-49m

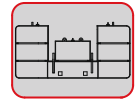

54t

Unit: t

Main boom length	42.5m																	
	19.0m			22.0m			25.0m			28.0m			31.0m			34.0m		
Luffing jib length																		
Luffing jib angle	84.0°	76.0°	66.0°	84.0°	76.0°	66.0°	84.0°	76.0°	66.0°	84.0°	76.0°	66.0°	84.0°	76.0°	66.0°	84.0°	76.0°	66.0°
10.0m																		
12.0m																		
14.0m	23.0																	
16.0m	23.0			23.0														
18.0m	23.0			23.0			23.0			23.0								
20.0m	22.5			22.6			22.3			22.0			21.7			21.4		
22.0m	2.6	18.7		2.1			2.1			19.8			19.5			19.3		
24.0m	18.8	17.2		18.5	16.7		17.9			18.0			17.7			17.5		
26.0m		15.6		17.2	15.3		16.6	15.7		16.1			16.2			16.4		
28.0m		14.4			14.1		15.5	13.9		15.0	13.6		14.7	13.4		14.7		
30.0m		13.3			14.0		14.3	12.9		14.2	12.6		13.6	12.3		13.3	12.1	
32.0m			1.6		13.0			11.9		13.9	11.7		12.8	11.5		12.4	11.2	
34.0m			9.8			9.6		11.5			1.8		12.2	1.6		11.7	1.4	
36.0m			9.2			9.0		1.3	8.7		1.6		11.2	9.9		11.2	9.7	
38.0m						8.4			8.2		9.4	7.9		9.2		1.3	9.3	
40.0m						7.8			7.6			7.4		8.6	7.2		8.4	
42.0m									7.2			6.9		8.7	6.7		7.9	6.5
44.0m												6.6			6.3		7.4	6.1
46.0m												6.1			5.9			5.7
48.0m															5.6			5.4
50.0m																		5.8
52.0m																		4.8



Luffing Jib Load Chart



33.5m-48.5m

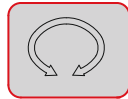

360°



19m-49m

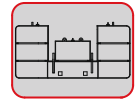

54t

Unit: t

Main boom length	42.5m																			
Luffing jib length	37.0m			4.0m			43.0m			46.0m			49.0m							
Luffing jib angle	84.0°	76.0°	66.0°	84.0°	76.0°	66.0°	84.0°	76.0°	66.0°	84.0°	76.0°	66.0°	84.0°	76.0°	66.0°					
10.0m																				
12.0m																				
14.0m																				
16.0m																				
18.0m																				
20.0m																				
22.0m	19.0			11.5																
24.0m	17.2			11.5			11.5			11.5										
26.0m	15.7			11.5			11.5			11.5			9.8							
28.0m	14.5			11.5			11.5			11.5			9.9							
30.0m	13.4			11.5			11.5			11.5			10.0							
32.0m	12.2		2.0	11.5			11.5			11.5			9.9							
34.0m	11.3		1.2	1.4		10.0	11.2		9.8	1.8		9.6								
36.0m	1.7		9.5	1.2		9.3	8.3		9.3	9.3		8.8	8.8							
38.0m	1.9		8.8	9.7		8.7	8.1		8.4	6.5		8.2	7.5		8.0					
40.0m	9.4		8.2	9.2		8.3	7.6		7.8	6.3		7.6	5.0		7.4					
42.0m	8.8		7.7	8.7		7.5	7.1		7.3	5.9		7.9	4.7		6.9					
44.0m			7.2	5.9	8.1		7.2	6.7		6.8	5.5		6.6	4.4		6.4				
46.0m			6.8	5.5			6.6	5.3	6.3		6.4	5.9		6.2	5.0		6.0			
48.0m			6.4	5.2			6.2	5.0	6.0		6.0	4.7	4.7		5.8	3.7		5.6		
50.0m			4.8		5.8		4.6	5.6		4.5	4.4		5.4	4.2	3.4		5.2			
52.0m			4.6		4.4		5.3		4.1	4.4		5.7	3.9	3.1		4.0	3.7			
54.0m			4.3		5.0		3.9		3.9		4.7		3.7	3.7		3.4				
56.0m			3.9		3.6		3.6		3.6		4.4		3.4	3.4		3.2				
58.0m			3.4		3.2		3.1		3.0		3.1		3.0	2.8						
60.0m			3.2		2.8		2.6		2.6		2.8		2.6							
62.0m			2.8		2.6		2.6		2.6		2.8		2.6							



Luffing Jib Load Chart



33.5m-48.5m

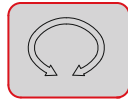

360°



19m-49m

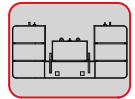

54t

Unit: t

Main boom length	45.5m																	
	19.0m			22.0m			25.0m			28.0m			31.0m			34.0m		
Luffing jib length																		
Luffing jib angle	84.0°	76.0°	66.0°	84.0°	76.0°	66.0°	84.0°	76.0°	66.0°	84.0°	76.0°	66.0°	84.0°	76.0°	66.0°	84.0°	76.0°	66.0°
10.0m																		
12.0m																		
14.0m																		
16.0m	23.0			23.0														
18.0m	23.0			23.0			23.0			23.0								
20.0m	2.5			22.3			22.2			21.7			21.4			21.1		
22.0m	18.3			17.8			19.9			19.6			19.3			19.2		
24.0m	16.8	16.7		16.3			15.9			17.8			17.5			17.3		
26.0m		15.3		15.1	15.3		14.8	14.8		14.3			16.6			15.8		
28.0m		14.2		14.2	13.9		13.7	13.6		13.3	13.3		12.9			14.6		
30.0m		13.7			12.9		12.8	12.6		12.4	12.3		12.1	13.0		11.7		
32.0m					11.9			11.7		11.6	11.5		11.2	11.2		1.9	11.8	
34.0m			9.5		11.5			1.9			1.6		1.6	1.4		1.2	1.2	
36.0m			8.9			8.7		1.1			9.9		1.1	9.7		9.7	9.5	
38.0m				8.3				8.0			9.2			9.6		9.1	8.9	
40.0m						7.6			7.4		8.6	7.1		8.5			8.3	
42.0m								7.0			6.7			7.9	6.5		7.8	
44.0m								6.5			6.3			6.8			7.3	5.9
46.0m											5.9			5.7				5.5
48.0m														5.4				5.2
50.0m														5.6				4.9
52.0m																		4.6



Luffing Jib Load Chart



33.5 m-48.5m

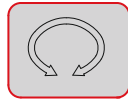

360°



19m-49m

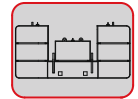

54t

Unit: t

Main boom length	45.5m														
	37.0m			4.0m			43.0m			46.0m			49.0m		
Luffing jib length															
Luffing jib angle	84.0°	76.0°	66.0°	84.0°	76.0°	66.0°	84.0°	76.0°	66.0°	84.0°	76.0°	66.0°	84.0°	76.0°	66.0°
10.0m															
12.0m															
14.0m															
16.0m															
18.0m															
20.0m															
22.0m	11.5			11.5											
24.0m	11.5			11.5			11.5								
26.0m	11.5			11.5			11.5			11.5			9.8		
28.0m	11.5			11.5			11.5			11.5			9.9		
30.0m	11.5			11.5			11.5			11.5			10.0		
32.0m	1.6	1.7		11.5			11.5			11.5			9.9		
34.0m	9.9	1.1		9.7	9.8		11.2			1.8			9.6		
36.0m	9.3	9.3		9.0	9.8		8.7	8.8		9.6			8.9		
38.0m	8.8	8.6		8.5	8.4		8.1	8.3		6.9	8.2		7.7	7.8	
40.0m	8.3	8.6		8.5	7.9		7.7	7.6		6.4	7.4		5.4	7.2	
42.0m	7.9	7.5		7.6	7.3		7.2	7.1		5.9	6.9		4.8	6.8	
44.0m		7.6		7.3	6.9		6.8	6.7		5.5	6.5		4.4	6.2	
46.0m		6.6	5.3		6.5		6.4	6.2		5.1	6.5		4.6	5.8	
48.0m		6.2	4.9		6.6	4.7	6.2	5.8		4.8	5.7		3.7	5.4	
50.0m			4.6		5.7	4.4		5.5	4.2	4.5	5.4		3.4	6.0	
52.0m			4.4			4.2		5.2	3.9		5.0	3.7	3.2	4.2	
54.0m			5.0			4.0		4.8	3.7		4.7	3.5	2.9	3.8	3.2
56.0m			3.8			3.7			3.4		4.4	3.2		3.5	4.0
58.0m						3.4			3.2			3.3		3.2	2.8
60.0m									3.2			2.8		3.0	2.6
62.0m									2.8			2.6			2.4



Luffing Jib Load Chart



33.5m-48.5m

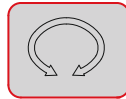

360°



19m-49m

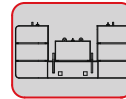

54t

Unit: t

Main boom length	48.5m																	
	19.0m			22.0m			25.0m			28.0m			31.0m			34.0m		
Luffing jib length																		
Luffing jib angle	84.0°	76.0°	66.0°	84.0°	76.0°	66.0°	84.0°	76.0°	66.0°	84.0°	76.0°	66.0°	84.0°	76.0°	66.0°	84.0°	76.0°	66.0°
10.0m																		
12.0m																		
14.0m																		
16.0m	23.0			23.0														
18.0m	22.6			23.0			23.0			23.0								
20.0m	17.8			20.2			21.0			21.1			21.1					
22.0m	16.2			15.9			18.1			18.8			19.0					11.5
24.0m	14.8	16.2		14.5			14.3			16.3			17.1					11.5
26.0m		14.9		13.3	14.6		13.0			12.9			14.8					11.5
28.0m		13.7		12.4	13.5		12.0	13.2		11.7	12.9		11.7					11.5
30.0m		12.7			12.5		11.2	12.2		10.8	12.0		10.5	11.7				10.7
32.0m		11.8			11.6			11.4		10.1	11.1		9.8	10.9				9.5 10.7
34.0m					10.8			10.6		9.6	10.3		9.2	10.1				8.9 9.9
36.0m			8.4					9.8			9.6		8.7	9.4				8.4 9.2
38.0m			7.9			7.7			7.4		9.0			8.8				7.9 8.6
40.0m			7.4			7.2			7.0		8.4	6.7		8.2				8.0
42.0m						6.7			6.5			6.3		7.7	6.1			7.5
44.0m									6.1			5.9			5.7			7.0 5.5
46.0m												5.5			5.3			6.6 5.1
48.0m												5.2			5.0			4.8
50.0m															4.7			4.5
52.0m																		4.3
54.0m																		4.0
56.0m																		



Luffing Jib Load Chart



33.5m-48.5m

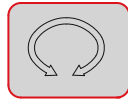

360°



19m-49m

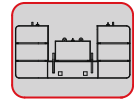

54t

Unit: t

Main boom length	48.5m															
Luffing jib length	37.0m			40.0m			43.0m			46.0m			49.0m			
Luffing jib angle	84.0°	76.0°	66.0°	84.0°	76.0°	66.0°	84.0°	76.0°	66.0°	84.0°	76.0°	66.0°	84.0°	76.0°	66.0°	
10.0m																
12.0m																
14.0m																
16.0m																
18.0m																
20.0m																
22.0m	11.5															
24.0m	11.5			11.5			11.5									
26.0m	11.5			11.5			11.5			11.5			9.8			
28.0m	11.5			11.5			11.5			11.5			9.9			
30.0m	11.5			11.5			11.5			11.5			10.0			
32.0m	9.7			11.2			11.5			11.5			9.9			
34.0m	8.6	9.7		8.9	9.5		10.2			10.7			9.6			
36.0m	8.0	9.0		7.8	8.8		8.1	8.5		9.3			9.1			
38.0m	7.6	8.4		7.3	8.2		7.0	7.9		7.3	7.7		8.0			
40.0m	7.2	7.8		6.9	7.6		6.6	7.4		6.3	7.2		5.9	6.9		
42.0m	6.8	7.3		6.5	7.1		6.2	6.9		5.9	6.7		4.9	6.5		
44.0m		6.8		6.2	6.6		5.9	6.4		5.6	6.2		4.5	6.0		
46.0m		6.4	4.9		6.2		5.6	6.0		5.2	5.8		4.1	5.6		
48.0m		6.0	4.6		5.8	4.4	5.3	5.6		4.8	5.4		3.8	5.2		
50.0m			4.3		5.5	4.1		5.3	3.8	4.5	5.1		3.5	4.9		
52.0m			4.0		5.2	3.8		5.0	3.6		4.8	3.4	3.2	4.2		
54.0m			3.8			3.6		4.7	3.3		4.5	3.1	3.0	3.9	2.9	
56.0m			3.5			3.4			3.1		4.2	2.9		3.6	2.7	
58.0m						3.1			2.9		4.0	2.7		3.3	2.5	
60.0m						2.9			2.7			2.5		3.1	2.3	
62.0m									2.5			2.3			2.1	
64.0m																



Safety Devices

Hook and boom overhoist prevention device

Hook and boom over hoist prevention device are used for preventing crane damage or turnover due to overhoist

Hook overhoist device

When the hook is lifted up as high as to touch the limit plumb, the microswitch will be activated and disconnected by the restoration of spring, cutting off the control circuit while the buzzer gives audible alarm and the indicator lights up. At the same time, the rise of the hook will stop automatically.

Boom overhoist device

Boom upper limit angle is sensed and controlled by moment limiter and boom upper limit switch. When lifting, the boom angle reaches the upper limit of 80° or more, the moment limiter gives out visual and audible alarm, and transmits the signal, makes the boom stop rising. At the same time, boom upper limit switch operates, and whose circuit is cut off, and the boom stops rising.

Moment limiter

The limiter can monitor the current load of all working attachments, the data of which can be set by buttons. 0% of rated load moment \leq load moment \leq 90% of rated load moment, and the moment limiter proportion bar shows green. 90% of rated load moment \leq load moment \leq 100% of rated load moment, and the moment limiter proportion bar shows yellow, at the same time, an intermittent audible alarm sounds. 100% of rated load moment \leq load moment \leq 105% of rated load moment, and the moment limiter proportion bar shows red, at the same time, a continuous audible alarm sounds. Load moment \geq 105% of rated load moment, and the moment proportion bar shows red, a continuous alarm sounds, at the same time transmits the signal. The main, aux.hook stops rising, boom stops derricking.

Brake and locking device

Main, aux.drums brake, derricking drum brake, swing brake and traveling brake.

Sensor

Pull sensor, used for testing the pull.
The angle sensor is installed on boom foot, used for testing boom angle.
The mechanical angle scale is also installed on the boom foot, to show the current angle of boom.

Swing alarm

Swing, at the same time, with buzzer alarm.



Boom Combinations



Main boom combinations

Boom length	Boom insert		
	3m	6m	9m
18	-	-	-
21	1	-	-
24	-	1	-
27	1	1	-
30	1		1
33	-	1	1
36	1	1	1
39	2	1	1
42	-	1	2
45	1	1	2
48	2	1	2
51	-	1	3
54	1	1	3
57	2	1	3
60	-	1	4
63	1	1	4
66	2	1	4
69	-	1	5
72	1	1	5
75	2	1	5



Boom Combinations



Jib combinations

Jib length	Insert		Boom length	Boom&jib angle
	3m	6m		
			39-63	15°、30°
13	1	-	39-63	15°、30°
19	1	1	39-63	15°、30°
25	1	2	39-63	15°、30°
31	1	3	39-63	15°、30°

Luffing jib combinations

Luffing jib length	Insert			Boom length	Boom angle
	3m	6m	9m		
				33.5~48.5	66°-84°
19	1	1	-	33.5~48.5	66°-84°
22	1	-	1	33.5~48.5	66°-84°
25	-	1	1	33.5~48.5	66°-84°
28	1	1	1	33.5~48.5	66°-84°
31	1	-	2	33.5~48.5	66°-84°
34	-	1	2	33.5~48.5	66°-84°
37	1	1	2	33.5~48.5	66°-84°
40	-	2	2	33.5~48.5	66°-84°
43	1	2	2	33.5~48.5	66°-84°
46	-	3	2	33.5~48.5	66°-84°
49	1	3	2	33.5~48.5	66°-84°



Transportation Dimensions and Weights

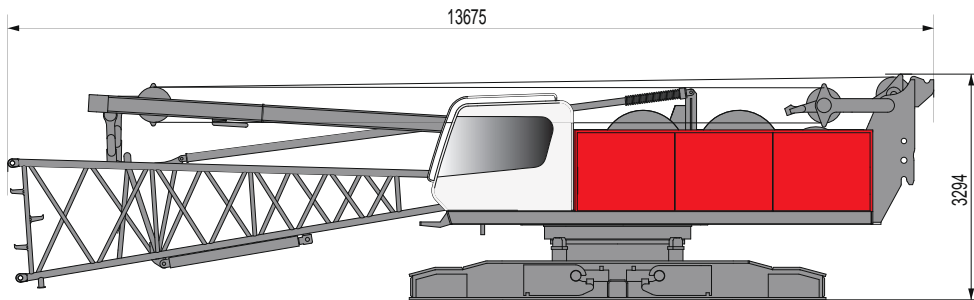

Basic machine	x1	
Length	13.675m	
Width	3.294m	
Height	3.300m	
Weight	36000kg	

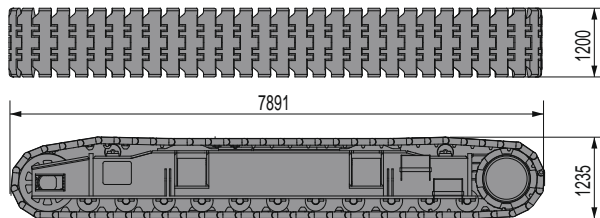

Track frame	x2	
Length	7.891m	
Width	1.235m	
Height	1.200m	
Weight	18500kg	

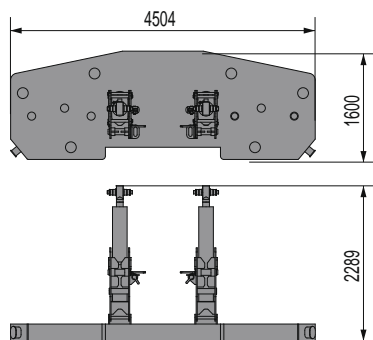

Counterweight	x1	
Length	4.504m	
Width	2.289m	
Height	16000m	
Weight	7000kg	

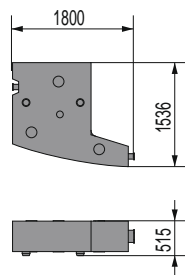

Counterweight A	x8	
Length	1.844m	
Width	1.616m	
Height	0.565m	
Weight	5470kg	

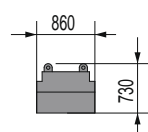

Counterweight B	x1	
Length	0.86m	
Width	0.86m	
Height	0.73m	
Weight	2152kg	



Transportation Dimensions and Weights

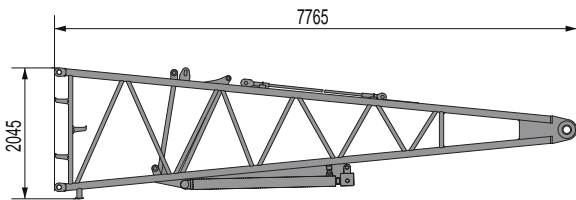

Boom foot	x1	
Length	7.765m	
Width	1830m	
Height	2.045m	
Weight	2012kg	

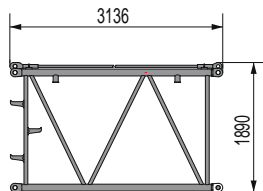

Boom 3m insert	x2	
Length	3.136m	
Width	1.700m	
Height	1.890m	
Weight	663kg	

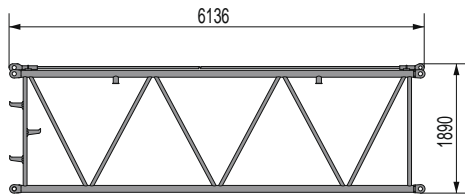

Boom 6m insert	x1	
Length	6.136m	
Width	1.700m	
Height	1.890m	
Weight	1086kg	

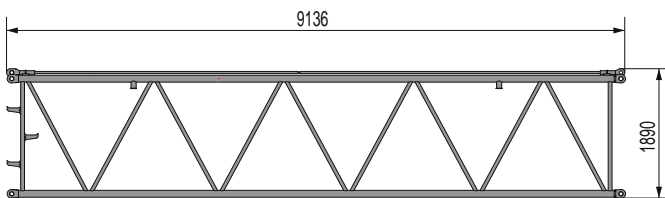

Boom 9m insert	x5	
Length	9.136m	
Width	1.700m	
Height	1.89m	
Weight	1361kg	

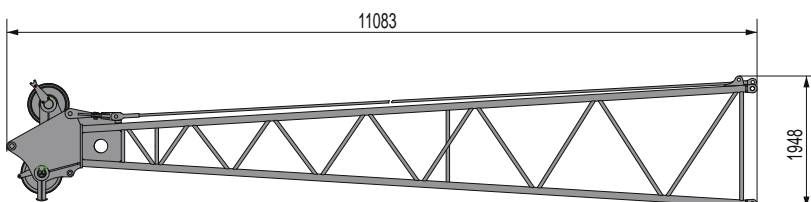

Boom head	x1	
Length	11.083m	
Width	1.810m	
Height	1.948m	
Weight	2460kg	



Transportation Dimensions and Weights

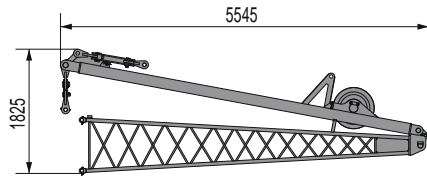

Fly jib foot	x1	
Length	5.545m	
Width	1.808m	
Height	1.825m	
Weight	919kg	

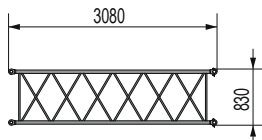

Fly jib 3m insert	x1	
Length	3.080m	
Width	1.006m	
Height	0.83m	
Weight	118.5kg	

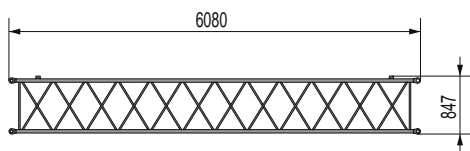

Fly jib 6m insert	x3	
Length	6.080m	
Width	1.006m	
Height	0.847m	
Weight	225kg	

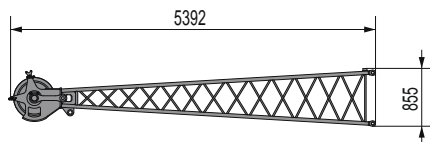

Fly jib head	x1	
Length	5.392m	
Width	0.991m	
Height	0.855m	
Weight	314kg	

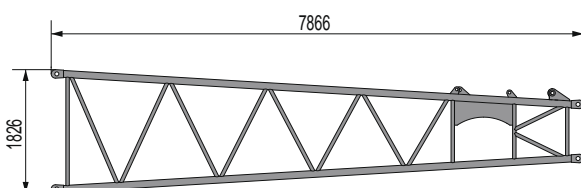

Tapered section	x1	
Length	7.866m	
Width	1.810m	
Height	1.825m	
Weight	1496kg	



Transportation Dimensions and Weights

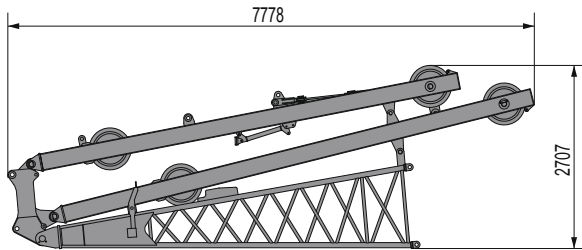

Luffing jib foot	x1	
Length	7.778m	
Width	1.420m	
Height	2.707m	
Weight	3051kg	

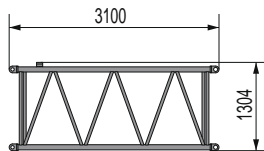

Luffing jib 3m insert	x1	
Length	3.100m	
Width	1.250m	
Height	1.304m	
Weight	280kg	

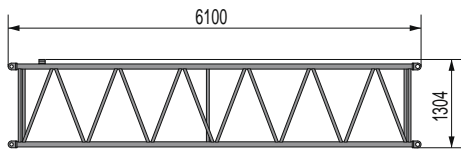

Luffing jib 6m insert	x3	
Length	6.100m	
Width	1.250m	
Height	1.304m	
Weight	495kg	

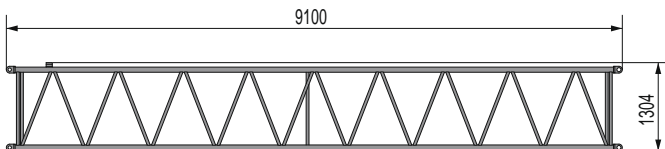

Luffing jib 9m insert	x2	
Length	9.100m	
Width	1.250m	
Height	1.304m	
Weight	709kg	

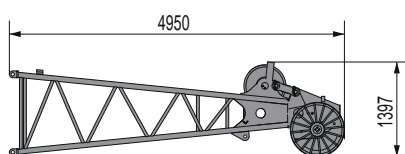

Luffing jib head	x1	
Length	4.950m	
Width	1.250m	
Height	1.397m	
Weight	786kg	



Transportation Dimensions and Weights

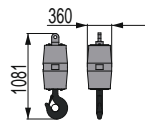

12.5t Hook x1

Length	0.360m
Width	0.360m
Height	1.081m
Weight	328kg

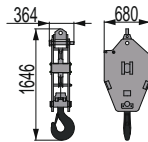

25t Hook x1

Length	0.680m
Width	0.364m
Height	1.646m
Weight	435kg

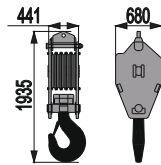

80t Hook x6

Length	0.680m
Width	0.441m
Height	1.935m
Weight	1030kg

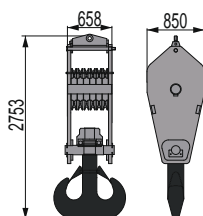

135t Hook x1

Length	0.850m
Width	0.658m
Height	2.753m
Weight	2809kg



Self-assembling Principle

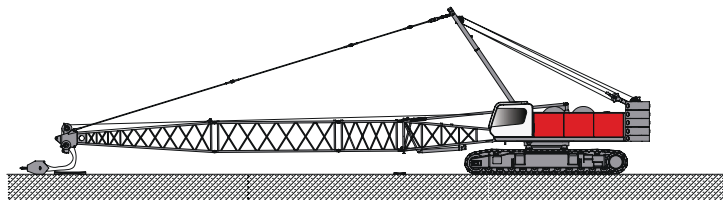
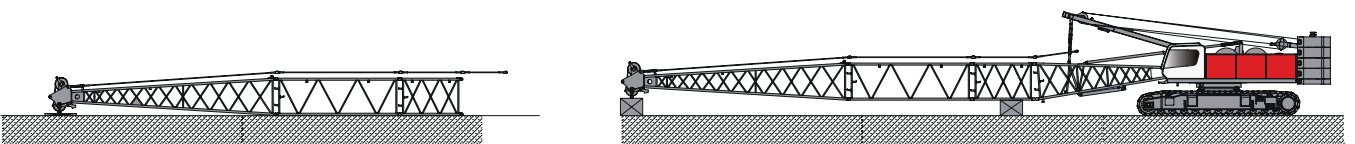
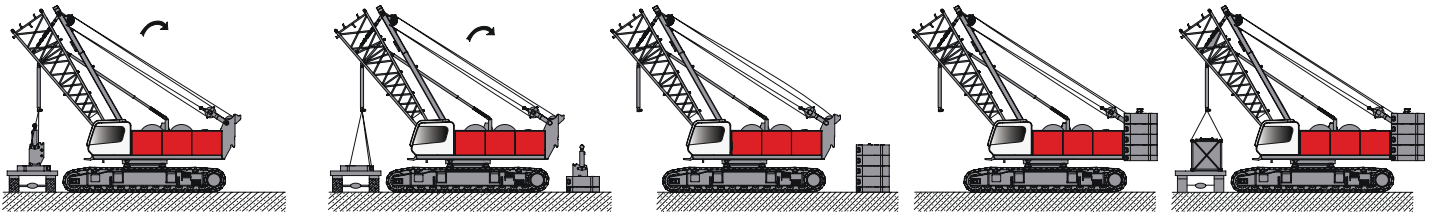
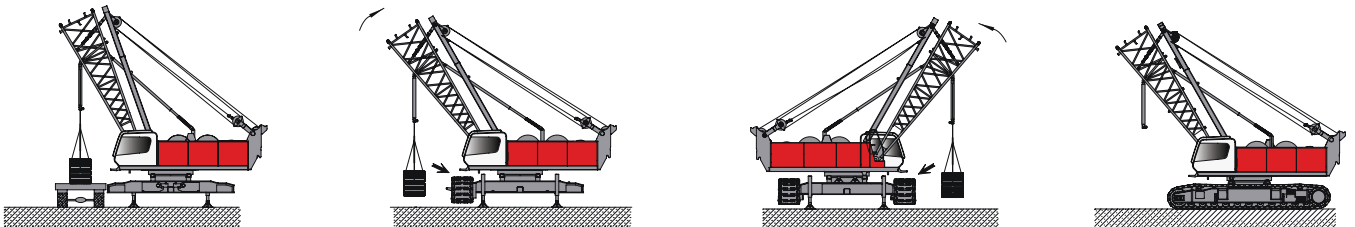
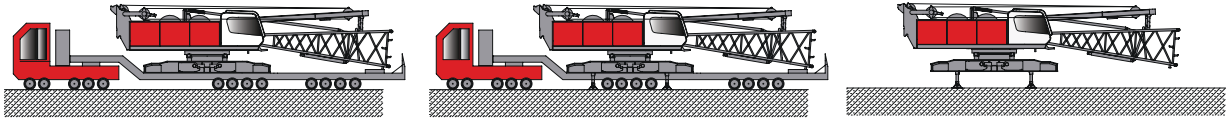



Fuwa Global Heavy Industry Co.Ltd. is a 100% subsidiary of Fuwa Heavy Industry Co.Ltd.
A dedicated partner for distribution and support of all Fuwa products.

Fuwa Heavy Industry Co.Ltd.
No.2 Shuangyang Road, Shuncheng District,
Fushun-Liaoning, China
P.C. 113126
Tel: +86-24-57649117/57642558
Fax:+86-24-57642766
Email: export@cnfuwa.com
WWW.FWXCRANE.COM