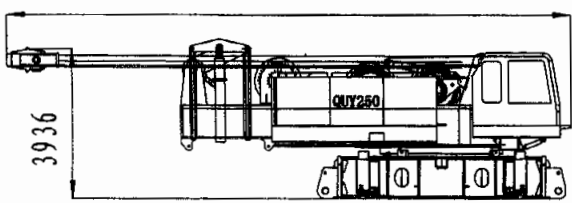
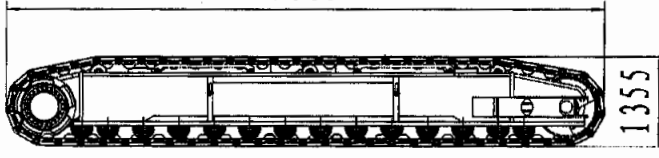
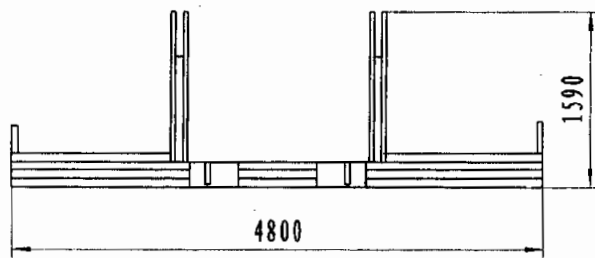

8.3 Dimensions and Weights of All Components

8.3.1 Base machine

Names	Dimensions (mm) Length×Width×Height	Weight (kg)	Qty
<p>Superstructure Including: bearing, front winch, rear winch, main derricking winch, mast, self-assembly cylinder, connecting part, central ballast, jack-up cylinder, counterweight, self-assembly device)</p>	<p style="text-align: center;">About 12m</p>  <p style="text-align: center;">12000×3280×3946</p>	54000	1
<p>Crawler assy Total width of the crawler: 7600mm Width of track shoe: 1200 mm</p>	<p style="text-align: center;">9365</p>  <p style="text-align: center;">9365×1540×1355</p>	23600	2

8.3.2 Counterweight

Names	Dimensions (mm) Length×Width×Height	Weight (kg)	Qty
<p>Counterweight (tray)</p>	 <p style="text-align: center;">4800×2155×1590</p>	17000	1

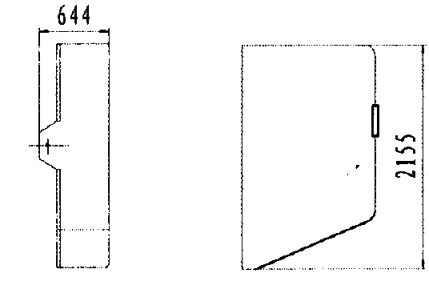
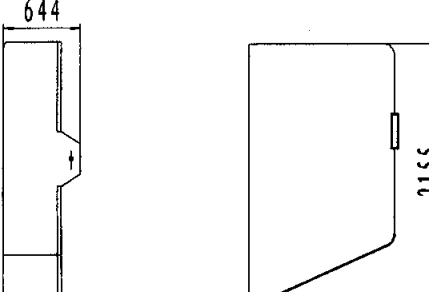
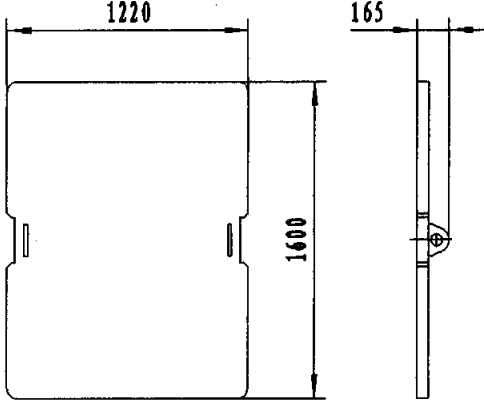
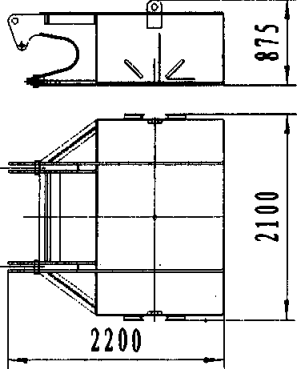

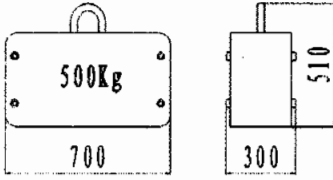
<p>Counterweight A</p>	 <p style="text-align: center;">2155 × 1220 × 644</p>	<p>6750 per piece</p>	<p>5</p>
<p>Counterweight B</p>	 <p style="text-align: center;">2155 × 1220 × 644</p>	<p>6650 per piece</p>	<p>5</p>
<p>Assistant counterweight</p>		<p>918 per piece</p>	<p>2</p>
<p>Central ballast</p>	 <p style="text-align: center;">2200 x 2100 x 875</p>	<p>11800 per piece</p>	<p>2</p>

Ballast on luffing jib top	 <p>500Kg 700 300 510 700×300×510</p>	500Kg	2
----------------------------	--	-------	---

8.3. 3 Boom System

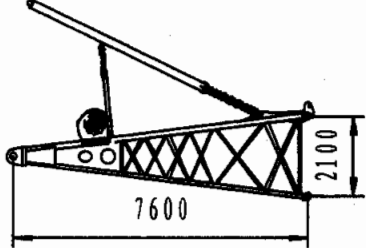
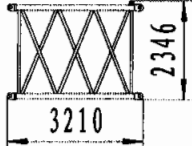
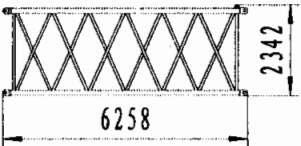
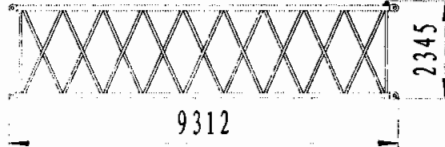
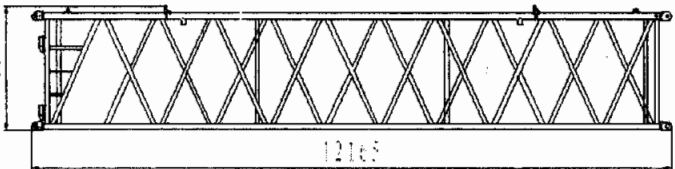
8.3.3.1 Main Boom

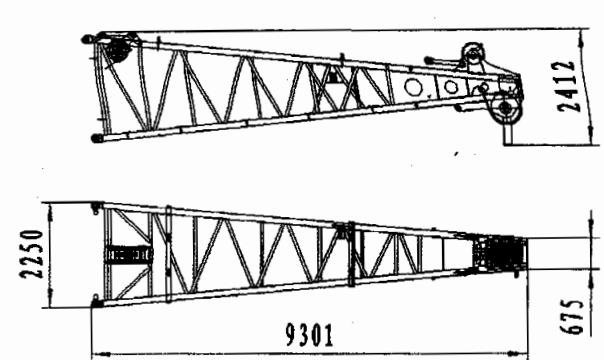
Names	Dimension (mm) Height	Length×Width×	Weight (kg)	Qty
7.6m boom foot Back stop : 3660 kg Aux. derricking winch: 2690 kg	 <p>2100 7600 7995×2282×2920</p>	7995×2282×2920	5849	1
3m boom insert	 <p>2346 3210 3210×2282×2346</p>	3210×2282×2346	830	1
6m boom insert	 <p>2342 6258 6258×2282×2346</p>	6258×2282×2346	1342	1
9m boom insert	 <p>2345 9312 9312×2282×2346</p>	9312×2282×2346	1845	4
12m boom insert	 <p>2346 12165 12165×2282×2346</p>	12165×2282×2346	2182	1

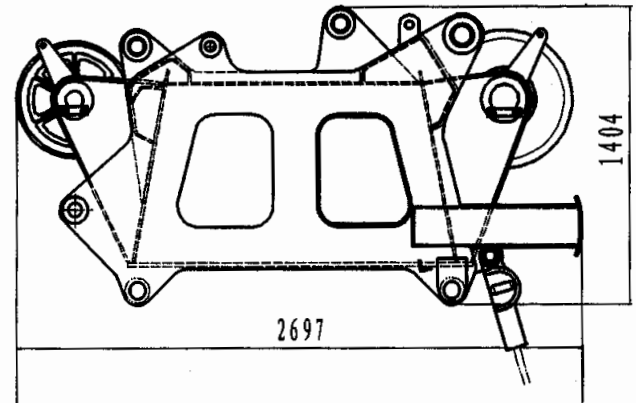
<p>8.8m boom head</p>		<p>2180</p>	<p>1</p>
<p>6. 7m tapered section</p>	 <p style="text-align: center;">6865 × 2282 × 2938</p>	<p>1998</p>	<p>1</p>
<p>Boom top</p>	 <p style="text-align: center;">2697 × 1200 × 1404</p>	<p>1983</p>	<p>1</p>

8.3.3.2 Luffing jib and fixed jib

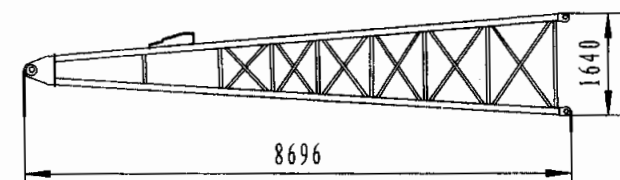
Names	Length × Width × Height Dimensions (mm)	Weight (Kg)	Qty
<p>Luffing jib foot (8.5m)</p>	 <p style="text-align: center;">8696 × 1630 × 1640</p>	<p>1442</p>	<p>1</p>

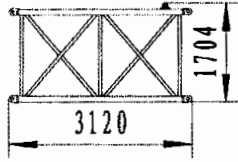
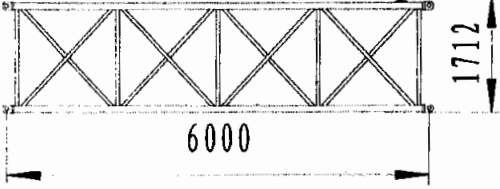
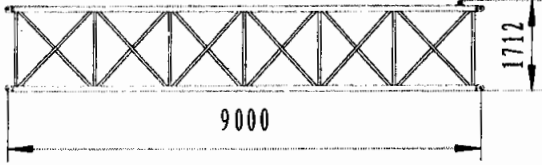
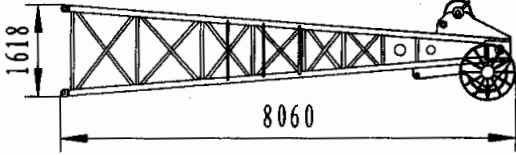
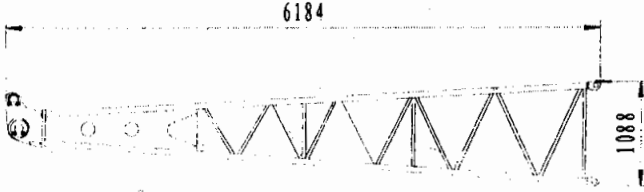
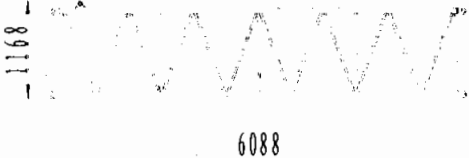
<p>3m light boom insert</p>	 <p>3120 × 1630 × 1704</p>	<p>408</p>	<p>1</p>
<p>6m light boom insert</p>	 <p>6135 × 1630 × 1766</p>	<p>663</p>	<p>1</p>
<p>9m light boom insert</p>	 <p>9135 × 1630 × 1712</p>	<p>946</p>	<p>4</p>
<p>Light duty boom top</p>	 <p>8060 × 1630 × 1628</p>	<p>1514</p>	<p>1</p>
<p>6m fixed jib foot</p>	 <p>6184 × 1620 × 1088</p>	<p>447</p>	<p>1</p>
<p>6m fixed jib insert</p>	 <p>6088</p>	<p>291</p>	<p>4</p>

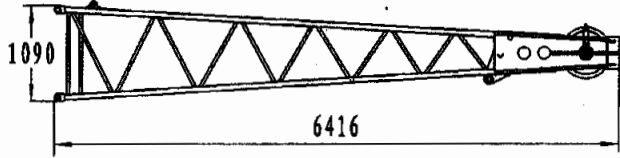
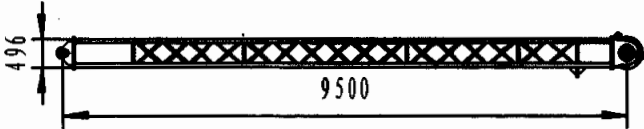
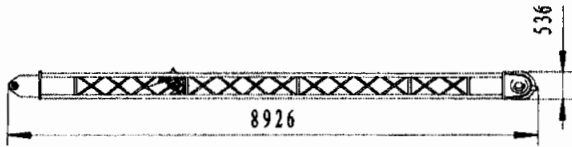
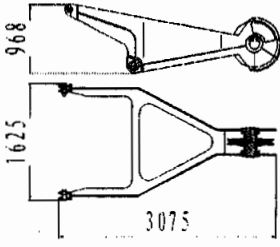
		6088 × 1276 × 1168		
6m fixed jib top		6416 × 1276 × 1090	400	1
Front strut		9930 × 1250 × 496	1280	1
Rear strut (with back stop)		8926 × 1250 × 666	1220	1
Runner		3075 × 1625 × 968	725	1

Note: . The weight of guy line is not included in the weight of boom system.

8.3.3.3 Dimensions and weights of Hook block

<p>250T Hook block</p>	<p>800 2787 1236 1158</p>	<p>3686</p>
<p>200T Hook block</p>	<p>800 2717 1092 964</p>	<p>3410</p>
<p>150T Hook block</p>	<p>800 2560 860 656</p>	<p>2620</p>

<p>80T Hook block</p>		<p>1342</p>
<p>35T Hook block</p>		<p>927</p>
<p>13.5T Hook block</p>		<p>848</p>

Note: The weight of hook block in the table may not be fully same as the actual weight of hook block. Please observe the actual weight of hook block.