

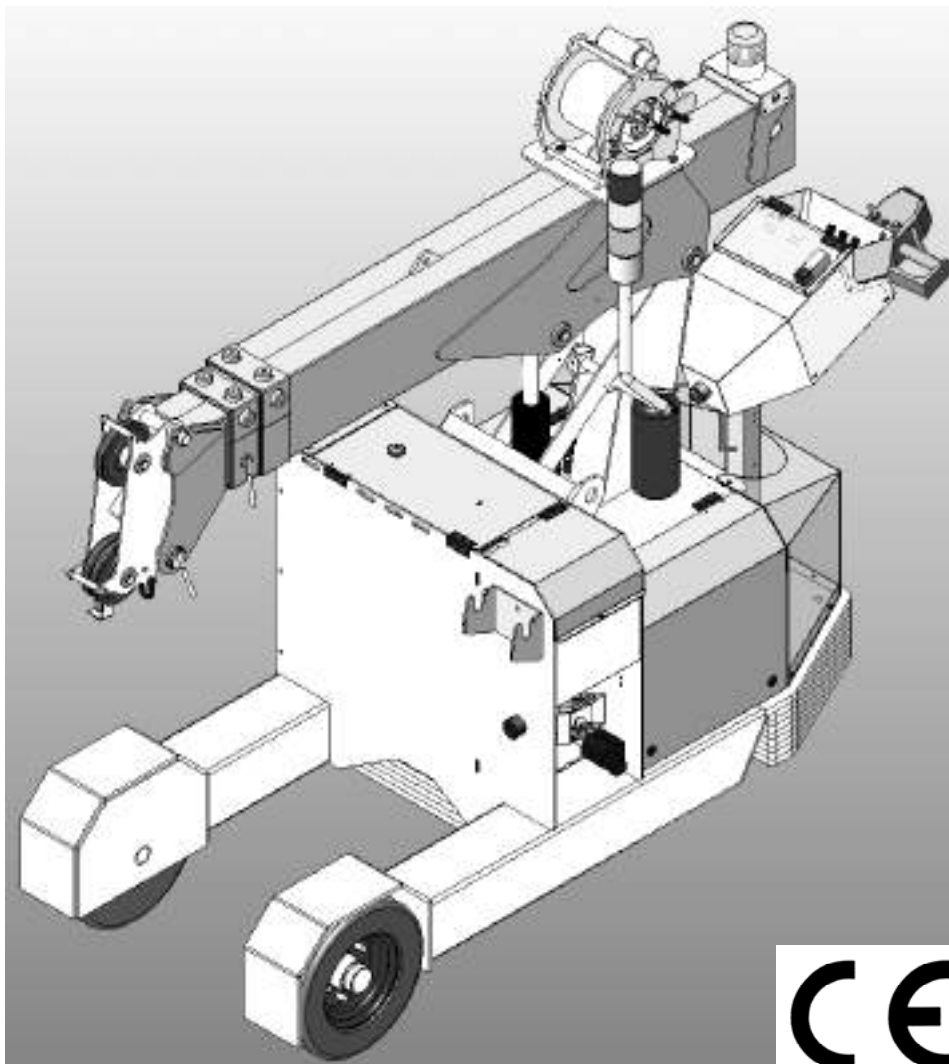

OPERATING AND MAINTENANCE MANUAL MPK20

SERIAL NUMBER: _____



Ormet spa

Via Campardone, 7

Z.I. Colle Umberto (TV)

Tel. +39 0438 434443 Fax +39 0438 430115

www.jekko.it www.ormet.it

E-mail info@ormet.it

Copyright © 2011

MANUAL REVIEW		
VERSION	DATE	REVIEW
1.0	09/2008	First Release
1.1	09/2011	Review 1
1.2	01/2014	Review 2 (int.2.8)



ORMET S.p.A. - Via Campardone, 7 - 31014 Colle Umberto (TV) - ITALY
Tel. +39 0438 434443 - Fax +39 0438 430115 - Cod. Fiscale e Partita IVA IT02156520260
Capitale Sociale € 2.000.000 i.v. - R.E.A. TV192307 - Reg. Imprese 02156520260
Unità Locale San Fior OVERMAT: via Marco Polo, 30 - 31020 San Fior (TV) - ITALY
Unità Locale Onè: via Castellana, 87 - 31010 Fonte (TV) - ITALY - Tel. +39 0423 949143
www.ormet.it - info@ormet.it





TABLE OF CONTENTS

TABLE OF CONTENTS	3
1 PREFACE	5
1.1 General Information	5
1.2 Technical Specifications	7
1.3 Original Seals	9
1.4 Operator Training	9
1.5 Intended use	9
1.6 Warranty	10
2 SAFETY INFORMATION	12
2.1 Rules	12
2.2 Noise	13
2.3 Conveyance of instructions	13
2.4 Dangerous zones	15
2.5 Emergency stop	15
2.6 Daily check	16
2.7 Features of the working area	16
2.8 Labels	17
3 MACHINE SIGNALS AND CONTROLS.....	21
3.1 Main switchboard	21
3.2 Tiller	22
3.3 Radio remote control	23
4 MAIN PART	24
5 USE OF THE MACHINE IN REGULAR WORKING CONDITIONS.....	27
5.1 Machine starting	27
5.2 Machine travel	28
5.3 Use of the crane	29
5.4 Use of by-pass	29
5.5 Alarm	30
5.6 Danger of turnover	31
6 HANDLING AND TRANSPORT.....	33
7 TROUBLESHOOTING	34
7.1 Alarms of battery charger model BC1	34



7.2	Alarms of battery charger model NG1	34
7.3	Alarms battery level and controller MDI	35
7.4	AUTO DIAGNOSTIC SLIM	36
8	STANDAR OPERATOR MAINTENANCE.....	37
8.1	Ordinary Maintenance	37
8.2	Battery recharging	38
8.3	How to increase the battery lifetime	39
8.4	General warnings for maintenance activity	39
8.5	Extraordinary maintenance	40
9	SERVICING FORMS	41
9.1	Introduction	41
9.2	Events that relieve the manufacturer from its liability	42
9.3	Maintenance and servicing register	42
10	ENCLOSURE.....	43
10.1	Summarizing list of maintenance and servicing interventions	43
10.2	Detailed Forms On Servicing And Maintenance	44
10.3	Form For The Conveyance Of Information	45
10.4	SLIM manual	46
10.5	Radio remote control manual	46
10.6	Hydraulic scheme	47



1 PREFACE

1.1 General Information

Each machine is equipped with a copy of this manual.

This instruction manual is intended to facilitate users and maintenance technicians to carry out all of the operations necessary to operate the machine under **safety conditions**.

Only fundamental operations have been described. After practicing with the machine, the user will be able to develop further technical skills.

Note: This manual is an integral part of the machine and must therefore accompany the machine should this be sold, passed on or moved to another place.

A proper training at the moment of delivering must complete the instructions described in this manual.

As regards the accessories, please read their own instruction and maintenance manual.

Keeping the Manual

The Manual shall always be kept with the machine, even in case of sale.

In case of resell of the machine, the manual must follow it in its present conditions, even in case of integrations and modifications sent by the manufacturer.

The Manual will always be kept with the machine until its last demolition: for this reason, it must be kept with care in a safe place.

In case this manual was lost or subject to wear, please order another copy from the manufacturer

Ownership information

This manual contains proprietary information. All rights are reserved.

No part of this manual may be reproduced or photocopied without prior written consent of ORMET SPA. Only customers to whom the manual has been supplied together with the machine are allowed to use it to carry out use and maintenance operations on the machine it refers to.

This manual deals with all normal operations to be performed by the machine and with the main regular maintenance operations required. The instruction herewith provided must be carefully observed in order to properly use the machine. Machine operator training is required to operate the machine. Take care not to perform operations and maintenance not recommended in this manual. Make sure that only suitably qualified and authorized personnel carries out servicing when dismantlement of some parts of the machine is required.

The manufacturer does not undertake any responsibility whatsoever for any direct or indirect damage to objects or pets arising from the use of this manual or the machine in other conditions than those stated herein. ORMET SPA reserves the right to modify or improve this manual and the machines without notice, even those sold under the same model this manual refers to, but having different serial numbers.

ORMET SPA reserves the right to change data equipment without prior notice as well as instructions for maintenance and other measures. The measurements, weights and performance etc. given in this manual are approximate and can vary depending on the equipment.

The CE marking approves the conformity by the machinery **guideline 2006/42/CE**.

Conventions:

Qualified technicians: people who have the necessary expertise, skill and knowledge concerning the standards, safety regulations and service conditions, to recognise and avoid any possible danger for people and damage to the processed materials and to the machine itself.

Right side: Right side of the system, as identified by the operator positioned in the back part of the crane, in front of the switchboard and of the valve bank.

Left side: Left side of the system, as identified by the operator positioned in the back part of the crane, in front of the switchboard and of the valve bank.

Marking

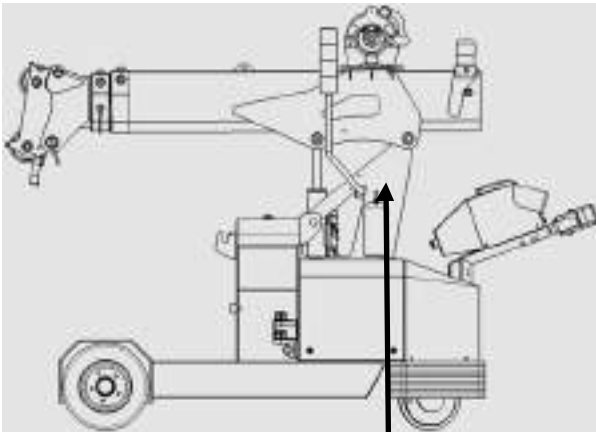

On the crane frame there is an identification plate bearing the machine's model, manufacturing number, year of manufacturing and weight. Model and number are also punched closed to the plate. The machine is supplied CE-marked where required by the market. The CE marking means that the machine meets the EU's requirements.



1.2 Technical Specifications

Model	MPK20
Maximum SWL	2000 kg 4409 lbs
Maximum working height	5 m 16.4 ft
Boom elevation	-25°/50°
Telescope	1,75-4,15m 5,74-13,6 ft
Dimensions	2600x950x1780 mm 8.53x3.1x5.8 ft
Weight	1.850 Kg 4078 lbs
Motor	24V-AC
Travel speed	0-3 km/h
Power	Electric 24V-DC 3kW (battery box 24V-345Ah)

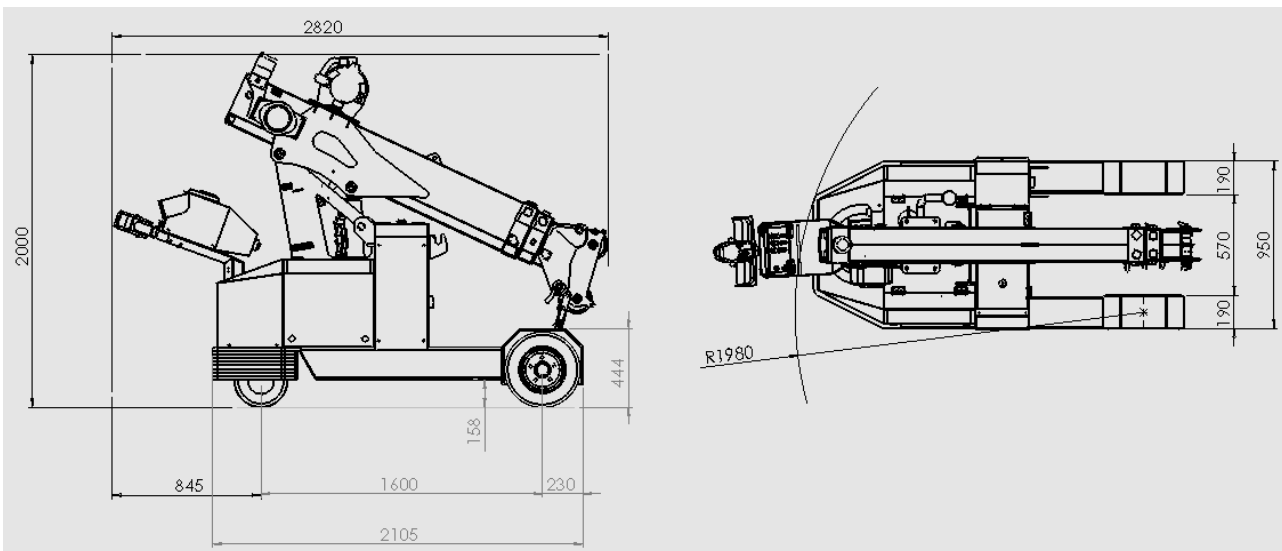

WHEELS LOAD • CARICHI RUOTE • RADGEWICHTEN • CARGOS RUEDAS • CHARGES ROUES							
	mm	205	500	1000	1500	2000	2500
	Kg	0	2000	1000	800	600	400
	Kg	1000	150	200	100	100	100
	Kg	475	1900	1375	1375	1225	1085

DIMENSIONS AND LOADING DIAGRAM OF THE CRANE WITH HOOK

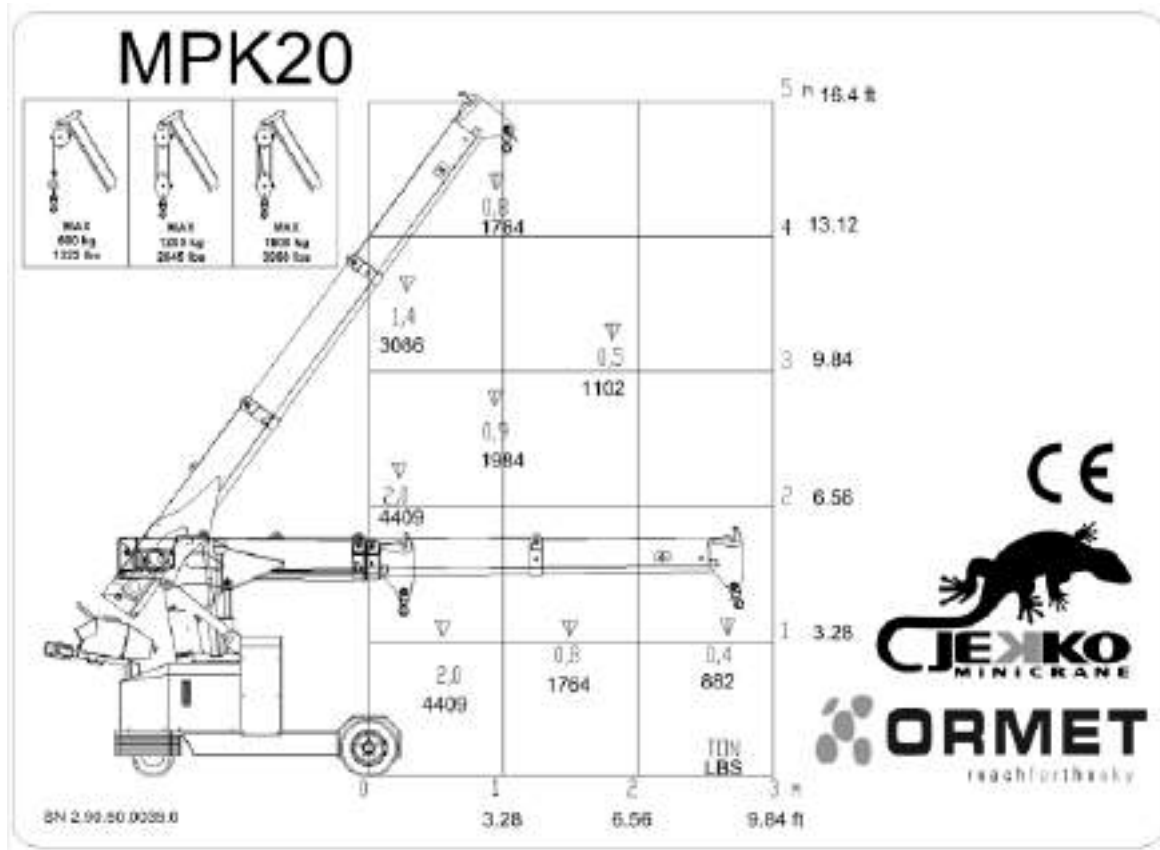

Apply the hook directly to the crane boom.



Check always the hook SWL capacity.

WINCH

The winch capacity is of 600 kg (see the winch CE plate).

The load limiting devices avoid the machine tilting while using the winch. In any case, the operator has to make sure not to lift loads exceeding the boom capacity.



Within the 600 kg -1323lbs loading capacity, the boom can lift loads exceeding the winch capacity thus activating the load limiting device. In order to lift heavier loads it is necessary to modify the pulley configuration by using a double or triple line pull.



The rope replacement or shortening has to be carried out by specialized technicians, only.

In order to increase the rope lifting capacity it is necessary to assemble the hook device as indicated in the picture and to set the machine by means of the switchboard. Every machine is equipped with a chart, as the one indicated in the picture, which indicates the winch lifting capacity depending on the configuration chosen.

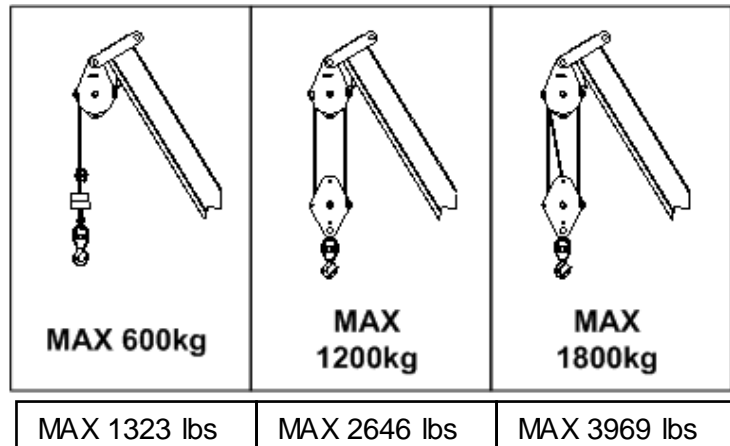

1.3 Original Seals

The manufacturer has placed lead sealings on machine components to assure working under safe conditions.



ORIGINAL SEAL REMOVAL WILL CAUSE MACHINE UNSAFE WORKING. THE MANUFACTURER DECLINES ANY RESPONSIBILITY ARISING FROM UNSAFE USE OF MACHINES.

1.4 Operator Training

Technical training is required to the operator in order to correctly operate this machine. ORMET SPA qualified personnel is available to train your personnel in many European countries. Contact your dealer for more information. If you can not find a dealer in your country please call OREMT SPA

1.5 Intended use

The machine has been designed to handle loads by means of a lifting hook, a winch or an accessory jib: loads must not exceed the load diagram printed or labelled on the crane. The machine is designed for internal use only.

- > All uses not expressly declared in this manual are to be considered not intended, especially any use different from those described in this manual.



CAUTION!
Inside the European Community it's forbidden use the machine to lift people

ATTENTION

THE MACHINE DON'T HAVE BEEN PROJECTED TO LIFT PEOPLE, IT DON'T RESPECT THE SAFETY REQUIREMET OF THE U.E. NORMATIVE FOR THIS KIND OF LIFTING

1.6 Warranty

ART.1 This warranty cancels and replaces any other kind of explicit or implicit warranty; any variations shall have no effect unless stated in a document issued by ORMET SPA Any disputes as to the interpretation or fulfilment of the warranty conditions shall be submitted to the jurisdiction of the court of Conegliano (TV).

ART.2 ORMET SPA' s warranty will expire after 12 months from the day of delivery of the machine to the final user. Within this period, ORMET SPA S.r.l. shall replace free of charge any parts that have manufacturing defects in ORMET SPA 's opinion.

ART.3 The warranty shall not cover any labour involved in assembling and dismantling the machine to replace the faulty parts, nor any transport costs for the delivery of the replacement parts. The warranty doesn't include goods damaged or perished after the forwarding from the factory.

ART.4 Under no circumstance is expected a refund for the machine's stop working because of the fault and the repairing. Delays on repairing don't give right to refund or extension of the warranty.

ART.5 The warranty does not include deficiencies and defects due to the normal wear of component parts that are usually subject to rapid and continuous wear (oil, grease, brass, ecc.). As for hydraulic devices dilate cylinders and bended piston rods are excluded because those events are caused by not right loads or not right movements of the machine.

ART.6 All requested spare parts should be invoiced at the price-list in force at the time of the enquiry. ORMET SPA shall acknowledge any right to replacements under warranty by means of a credit note.

ART.7 Equipment not manufactured by ORMET SPA and applied to ORMET SPA products – such as engines, electrical components and others – are not covered by this guarantee but by their own manufacturer's guarantee. ORMET SPA will warrant to its customers only and all the terms of the manufacturer's guarantee.

ART.8 The buyer shall not be entitled to interrupt payments or other obligations related to the purchase, even in case of a valid complaint. This warranty cancels and replaces any other kind of explicit or implicit warranty; any variations shall have no effect unless stated in a document issued by ORMET SPA.

ART.9 The warranty claim will be effective only if it is returned with the delivery verbal to ORMET SPA. within 30 days from the date of delivery of the machine. All warranty claims will have to be submitted to ORMET SPA within 8 days from the moment the damage occurred.

The warranty will expire in case of:

- Improper use of the machine (not complying with the instructions given)
- Non authorized modifications, repairs and dismantling (carried out by technicians non authorized by ORMET SPA)



- Use of non authorized accessories or accessories not fit for ORMET SPA's machines
- Wrong installation of the accessories and equipment the machine is supplied with
- Damages due to accidents, negligence, non-performance of periodical maintenance, use of non genuine spare parts
- Damages due to exceptional events.

Tampering with the safety seals placed on the valves or on the accessories will cause the warranty expiration and will release ORMET SPA of whatever liability.

Further information on responsibility

THE MANUFACTURER DECLARES HE WILL BE RELIEVED FROM ANY RESPONSIBILITY OR LIABILITY UNDER WARRANTY IN CASE OF:

- 1. Improper use of the machine*
- 2. Tampering with the machine or with its component parts*
- 3. Machine used by not authorized personnel*
- 4. Serious maintenance shortage*
- 5. Partial or complete non-observance of instructions*
- 6. Non-topping up of lubrication system in the periodical checks and non-filling in of relevant reports*
- 7. Non-performance of periodical checks*
- 8. Use of non genuine spare parts (spare parts not recommended by the manufacturer)*
- 9. Non authorized modifications and repairs*
- 10. Exceptional events*

2 SAFETY INFORMATION

The designing and manufacturing of this machine is based on specific safety criteria in compliance with the rules indicated on the CE certificate:

A careful risk assessment, carried out by the manufacturer, has allowed to remove the major risks connected both to scheduled and to rationally foreseeable operative conditions. Complete records about safety measures adopted can be found in the technical manual of the machine, which is kept by the manufacturer.

The manufacturer strongly recommends to follow all operative instructions and procedures herein described and to observe all safety rules at work, above all as regards both personal protection equipment and machine safety equipment. L'accurata analisi dei rischi svolta dal fabbricante ha consentito di eliminare la maggior parte dei pericoli connessi alle condizioni d'uso della macchina, sia previste che ragionevolmente prevedibili.

2.1 Rules

Some operative rules should be applied in order to best preserve environment and the operator's safety.

The operator

- He must be a healthy person
- He must be responsible
- He must have sense of direction
- He must act with circumspection when operating with the machine and be able to estimate dangers and working conditions.
- He must have quick reflexes.
- He must have very good powers of concentration.
- He mustn't be used to drink alcohols and to take drugs!

The operator must not wear:

- rings;
- watches;
- jewellery.
- torn clothes;
- scarves;
- unbuttoned shirts or smocks;
- jackets not zipped up;
- other clothes which could cause dangers with parts in motion

General directions

1st regulation

- Preserve your own safety!
- Preserve environment and animals!
- Take care nobody is exposed to dangers!
- Don't get on the machine, slipping danger!



2nd regulation

- Use personal protection equipment! (DPI)
- Be careful about sharp corners!

3rd regulation

- Prohibit unauthorized and untrained staff from using the machine!
- In case of alternation, the manual must pass from one to the following operator.
- Always operate with calm, precision and concentration!

Keep the machine clean in all of its component parts: handling members, switchboard and signalling apparatus.



- **Don't smoke.**
- **Don't use open fires.**

2.2 Noise



If workers are exposed to a time-weighted average (TWA) sound level of 85dB or more, hearing protectors are recommended. Hearing protectors must be worn by all operators exposed to a TWA of 90dB or more.

2.3 Conveyance of instructions

This chapter of the manual is intended to facilitate possible operations in case of change of operator and in case of inheritance of the machine due to sale.

THE OPERATIVE RESPONSIBLE OF THE MACHINE IS
THE ONE WHO,
having picked up the machine at the manufacturer's,
ACCEPTS THE ROLE OF OPERATOR.

BUT

The machine can be picked up for the purchaser by someone else, who won't be the final operator or owner.

① In this case, the one who picks up the machine will not be responsible for the machines, but **WILL TAKE UP THE ROLE OF "TEMPORARY OPERATOR" ONLY UNTIL THE MACHINE IS DELIVERED TO THE PURCHASER.**

① Each "temporary operator" must receive the machine operative instructions from the manufacturer and convey them to the person who, later, will be the effective machine **OPERATOR.**



BE CAREFUL!

When in the firm the same machine is to be used by more than one operator, working instructions as well as the use and maintenance manual must be conveyed to all the operators in charge of the machine.

How to convey the machine instructions

Train the new operator (or the new owner) properly.

- Make sure the operator understands instruction on safe operating and safety devices.
- Make sure the operator understands the information pertaining the machine's dangerous zone and component parts.
- Give the operating manual to the new operator (or to the new owner) and explain its contents to him.
- Tell him about the existence of the Declaration of Conformity and of the CE marking
- In case of resell, give the Declaration of Conformity to the new owner, and tell him about the hallmarks.
- Be sure the new operator has correctly understood the instruction and has no doubts about the machine's functioning.

How to prove the conveyance of instructions

Considering that a proper knowledge of the machine is absolutely necessary and that the operator, when ends its operative role, is no more responsible for it, we have prepared some forms intended to prove the machine has been correctly picked up at the manufacturer's site (**Declaration of responsibility**) and it has been properly conveyed in case of resell.



Lacking or incorrect conveyance of instructions and of the manual could cause involvement in (also penalty) punishment in case of environmental damage or harm suffered by persons, things or animals.

IN SHORT



Inform and train the new operator



Give him the manual and highlight safety instructions



Fill in the form in all details and sign it



It is in the conveyor's interest to take and keep a copy of the page proving the correct conveyance.

2.4 Dangerous zones

There are some very dangerous zones near the machine.
The dangerous zone is determined by the field of action of the crane.



It is absolutely forbidden to stay under hanging loads



There could be further dangers in the working area: please, observe the following rules



Don't work near electric wires, danger of death in case of contact with electric wires. While working, keep the following minimum distance from the power line:

Volt (KV)	Min dist. Insulated electric wire (M)
<1	3 (9.8 ft)
10	3.5 (114.8 ft)
15	3.5 (114.8 ft)
132	5 (16.4 ft)
220	7 (23 ft)

2.5 Emergency stop

Note: This procedure can be performed in any moment.

In compliance with the safety rules in force, the machine has been provided with emergency devices. They must be operated to reduce the stopping time when the usual stop procedure would not enable actual or impending danger to the operator or to the machine itself to be averted.



CAUTION!!!

Before putting the machine back into service, remove the cause of danger.

Location of emergency devices

The machine has been provided with several types of emergency devices.

- Emergency push-button - located on **main switchboard**
- Emergency push-button - located on **radio remote control**

About emergency devices

The main features of the installed emergency devices are:

Mushroom-shaped emergency push-button;

PUSH the mushroom-shaped button to stop the machine.

Machine back into service after emergency

In order to avoid unintended start-up, the emergency state remains active until the machine is put into service.

To put the machine back into service:

Note: Before putting the machine back into service, remove the cause of danger.

- Find out the push button used to activate the emergency state;
- Rotate the mushroom-shaped button in the direction indicated by the arrows printed on it;
- The push-button is now back in service and the machine is ready to work.
- Push the turn on engine button to start-up the machine

2.6 Daily check

Daily checks to be performed before starting the machine::

- Check hydraulic oil level
- Verify there is no visible oil leakage
- Check safety micro-switch. Remove possible mud, grease, etc. residues without using metal tools.
- Test safety systems
- Carpentry condition visual check
- Verify safety labels are present and readable
- Make sure the working area is ventilated as batteries produce explosive gases
- Check greasing of the machine

2.7 Features of the working area

To avoid unpleasant troubles or even accidents working areas have to meet specific requirements such as:

- Ground slopes smaller than 5 %;
- The wheel must lay on solid ground, without manhole, cover, etc.
- Check power supply availability at the voltage required by the machine and in conformity with the rules in force.











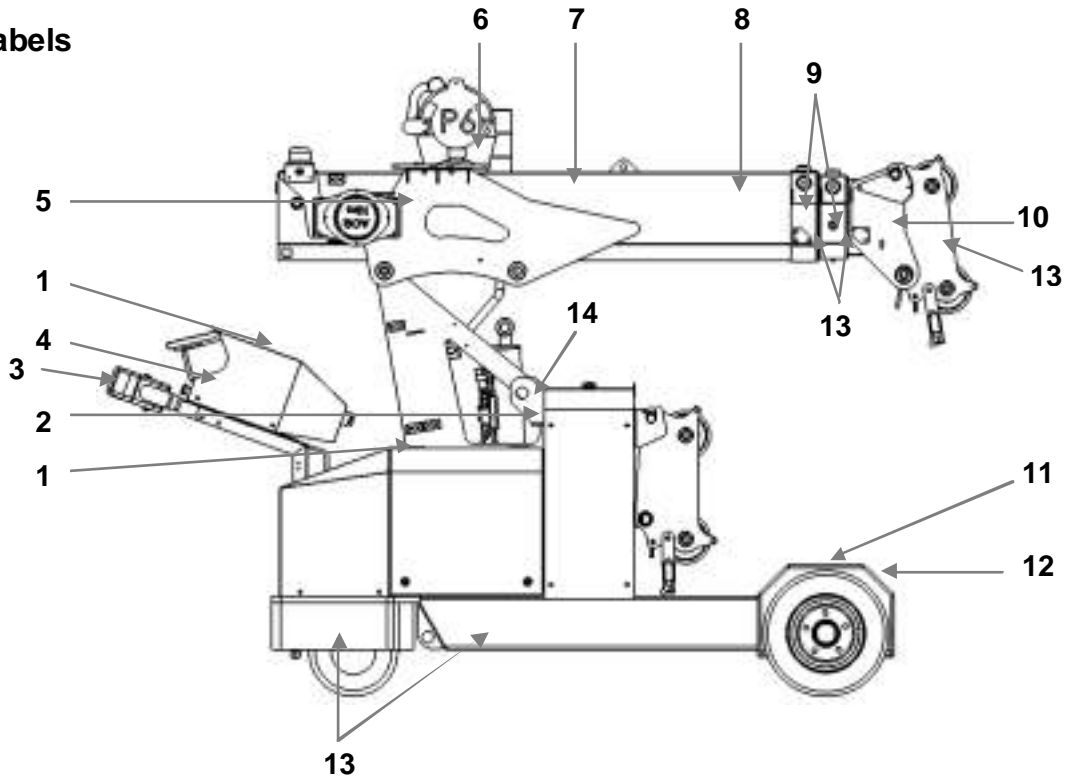



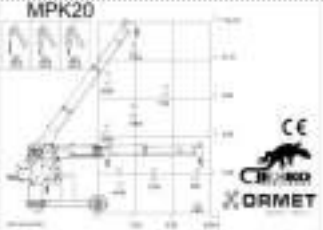

In case the machine has to work on upper floors, verify their maximum loading capacity according to what indicated in paragraph 'Technical Specifications'.

CAUTION!!!

Don't work on floors without having verified their loading capacity. The manufacturer declines any responsibility arising from damage or collapse.

2.8 Labels



1		2		3	
4		5		6	
7		8		9	
10		11		12	
13		14			

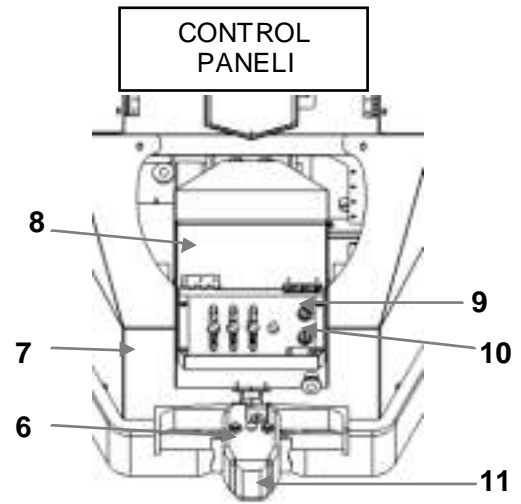
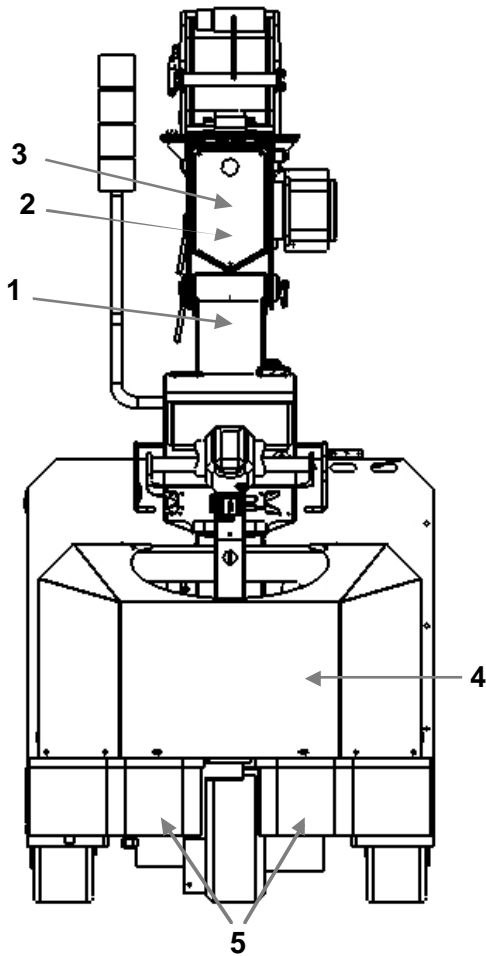

1		2		3	
4		5		6	
7		8		9	
10		11			

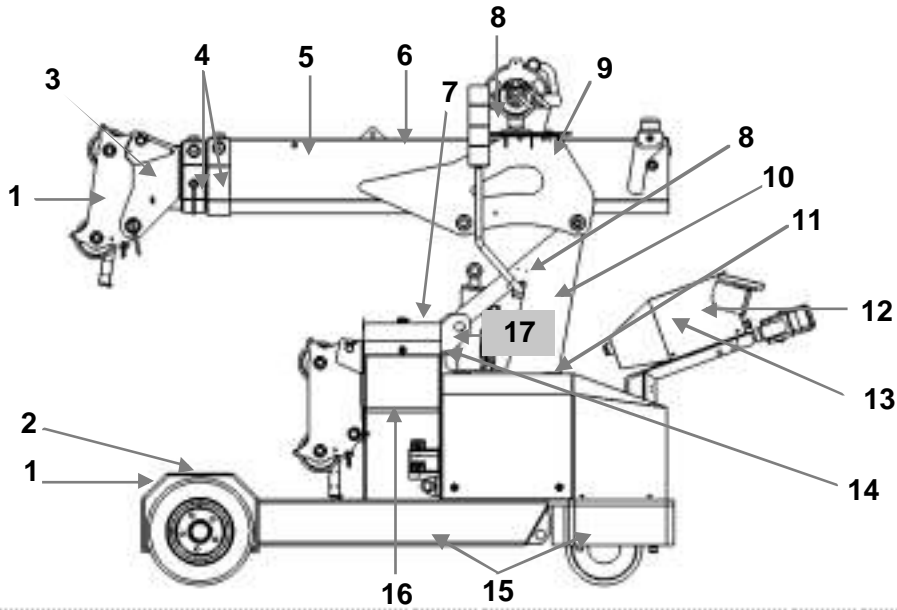

1		2		3	
4		5		6	MPK20W
7		8		9	
10		11		12	
13		14		15	
16		17			

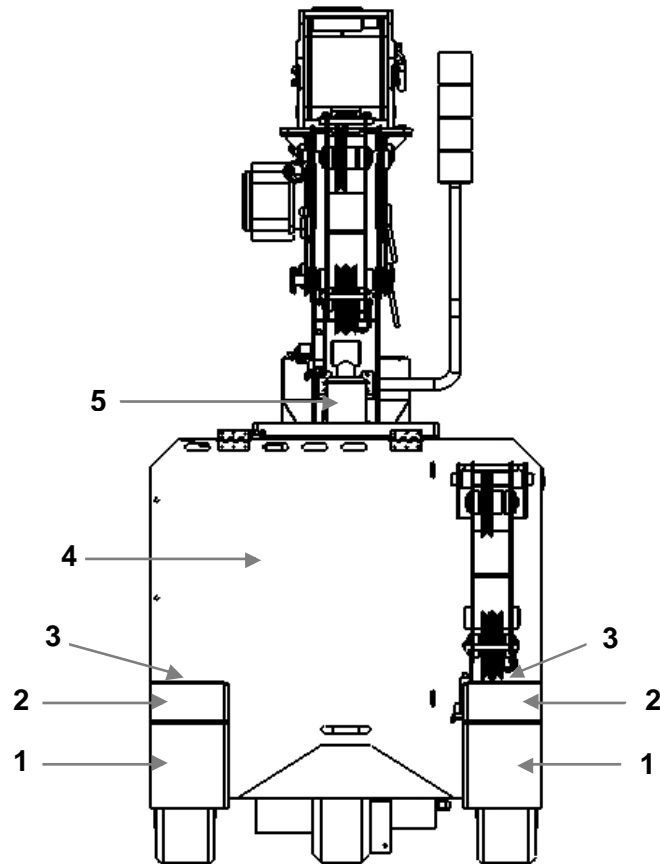

3 MACHINE SIGNALS AND CONTROLS

3.1 Main switchboard



Figura 1

Ref.	Descrizione
1	SLIM
2	BATTERY LEVEL AND CONTROLLER MDI ALARM
3	START/LOCAL/REMOTE SWITCH
4	BY-PASS
5	LIFTING
6	TELESCOPE
7	WINCH
8	EMERGENCY PUSH BUTTON

SLIM functions

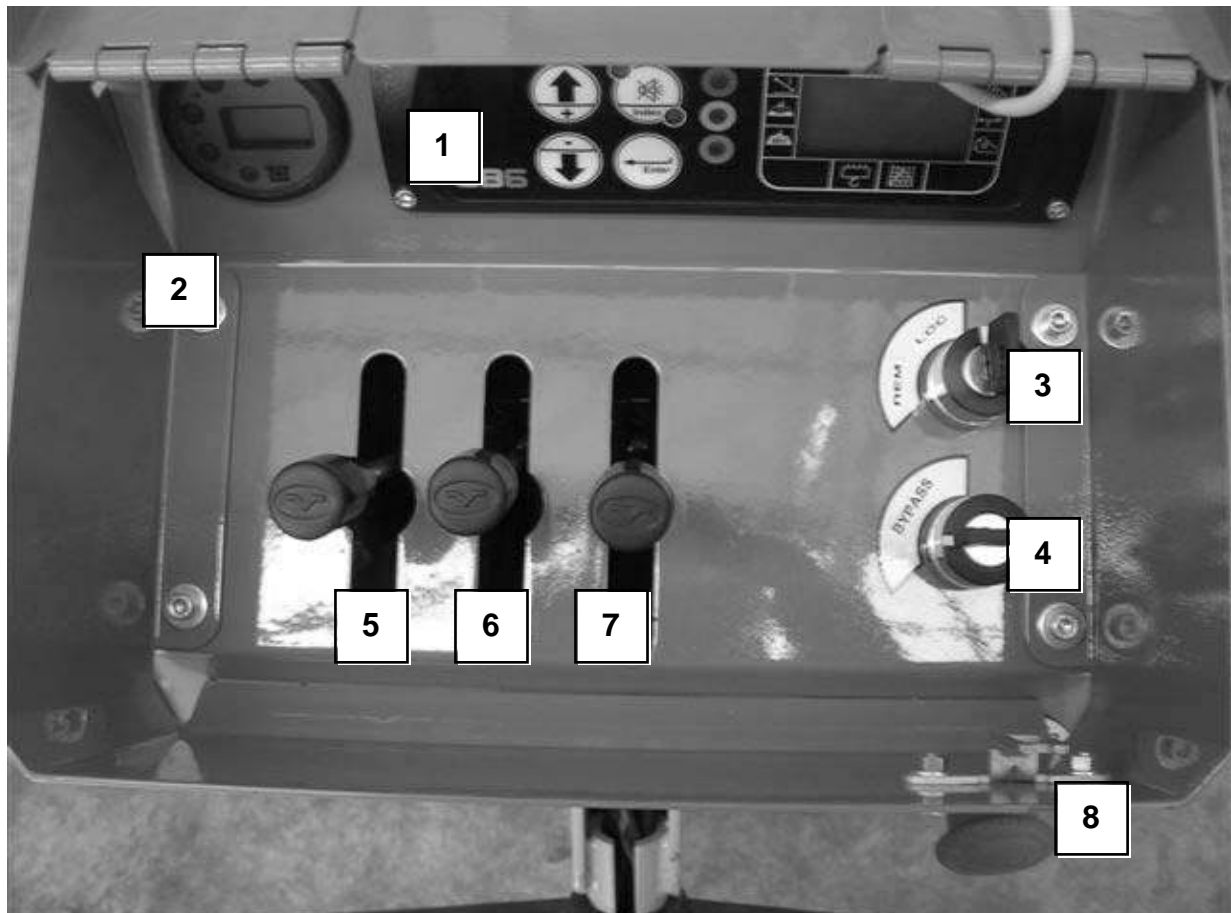
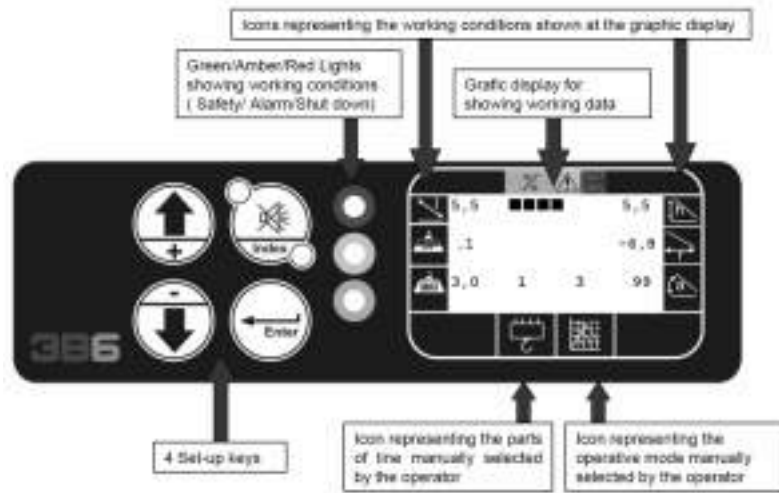

For use read his own instruction and maintenance manual attached.

3.2 Tiller



Figura 2

Ref.	Description
1	ON/OFF SWITCH
2	FRONT/BACK TRAVEL LEVER
3	EMERGENCY STOP
4	HORN

5	START BUTTON
---	--------------

3.3 Radio remote control

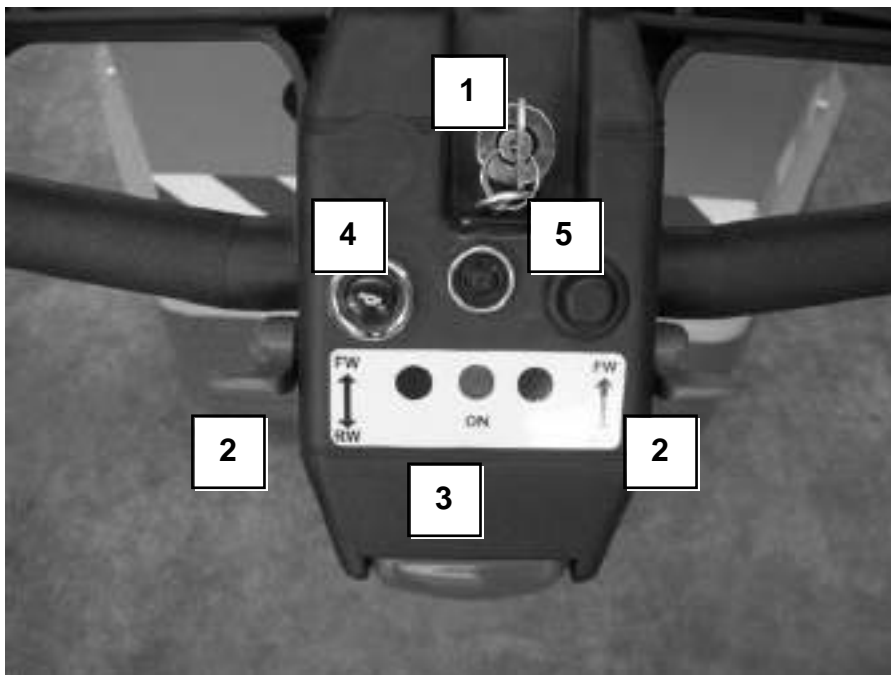

Figura 3

Ref.	Description
1	ON RADIO REMOTE CONTROL
2	EMERGENCY PUSHBUTTON
3	OPTIONAL
4	OPTIONAL

4 MAIN PART

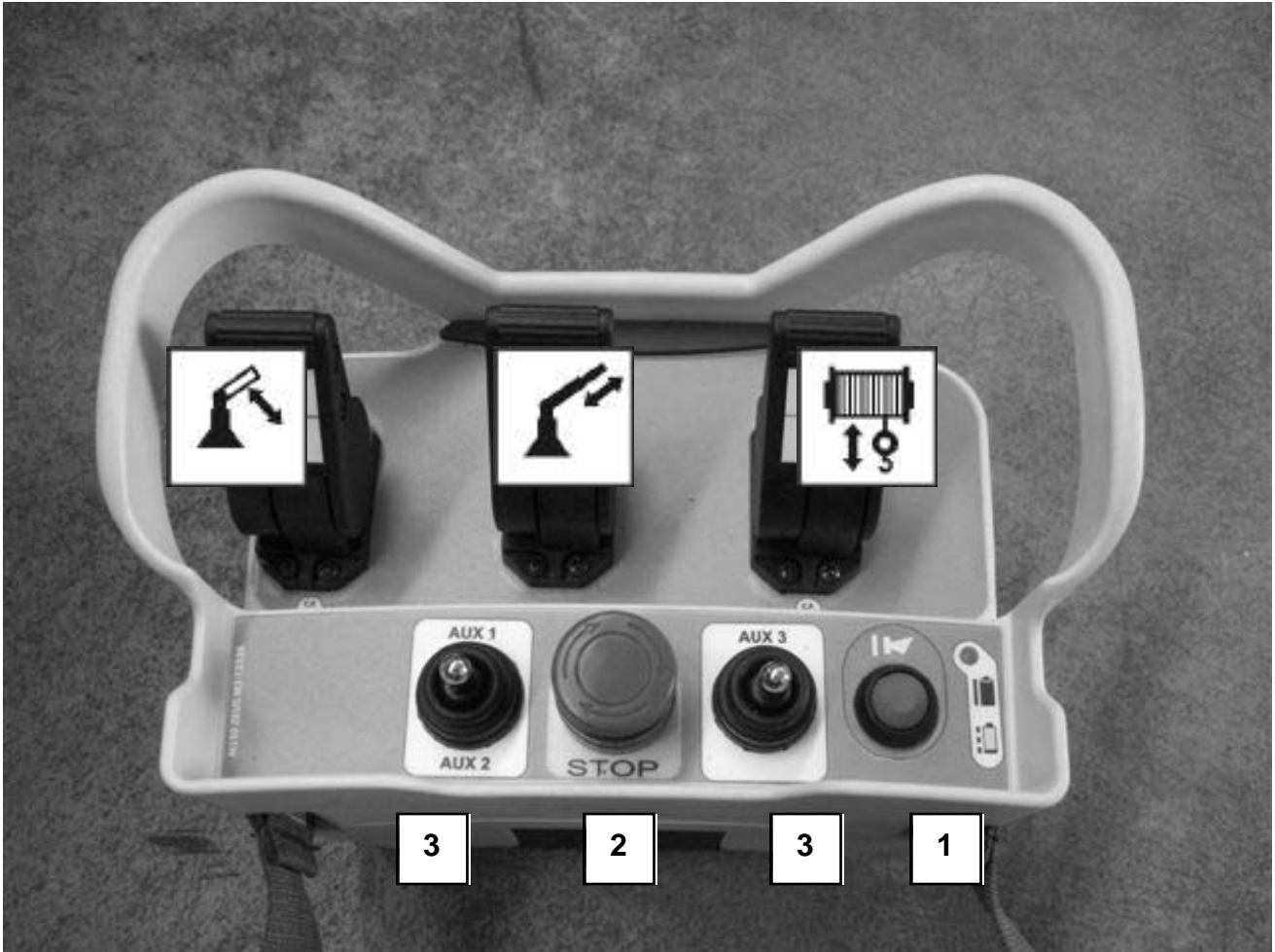
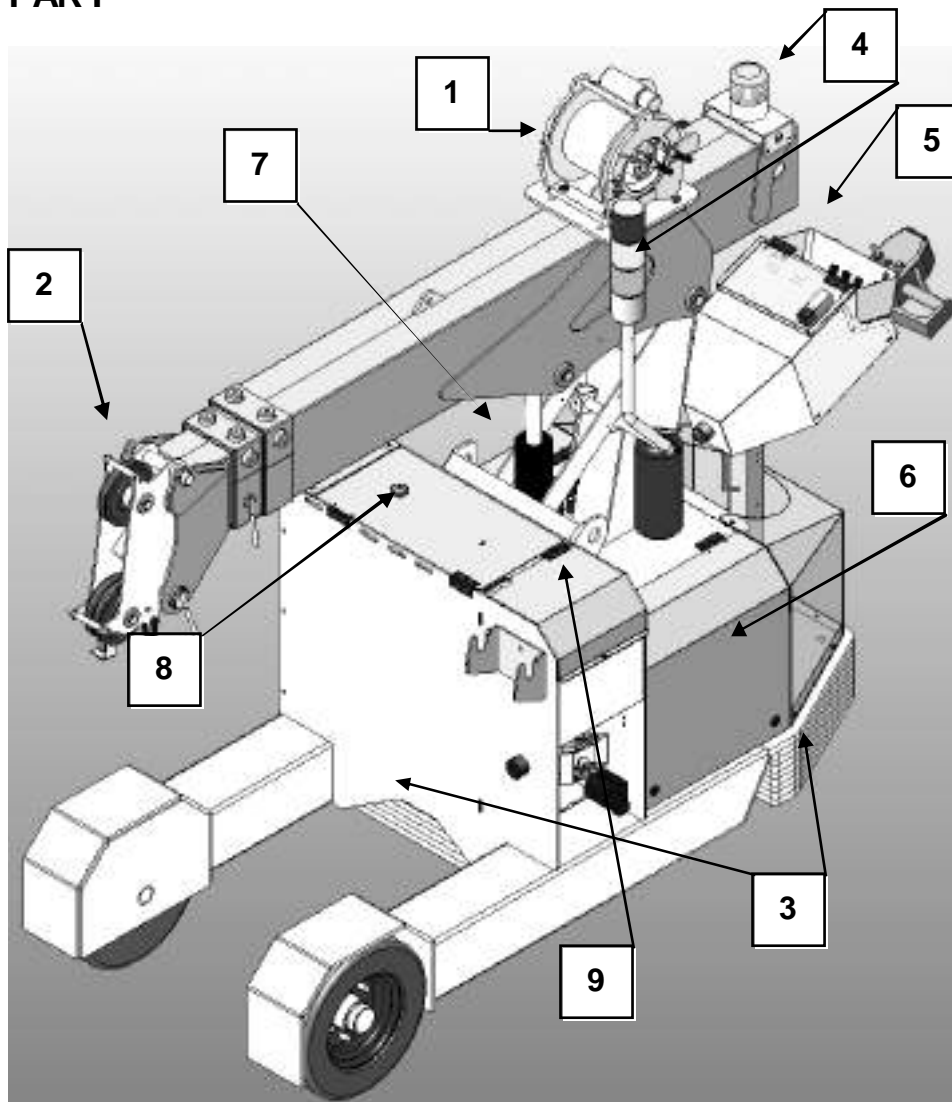

Ref.	Description
1	Winch
2	Pulley system
3	Counter-weight
4	Signal lights
5	Switchboard
6	Motor and electric compartment
7	Switchboard
8	Battery compartment
9	Free compartment



Figura 4

Inside the left compartment there are the components of the machine feeding system as well as a system controlling the machine running.

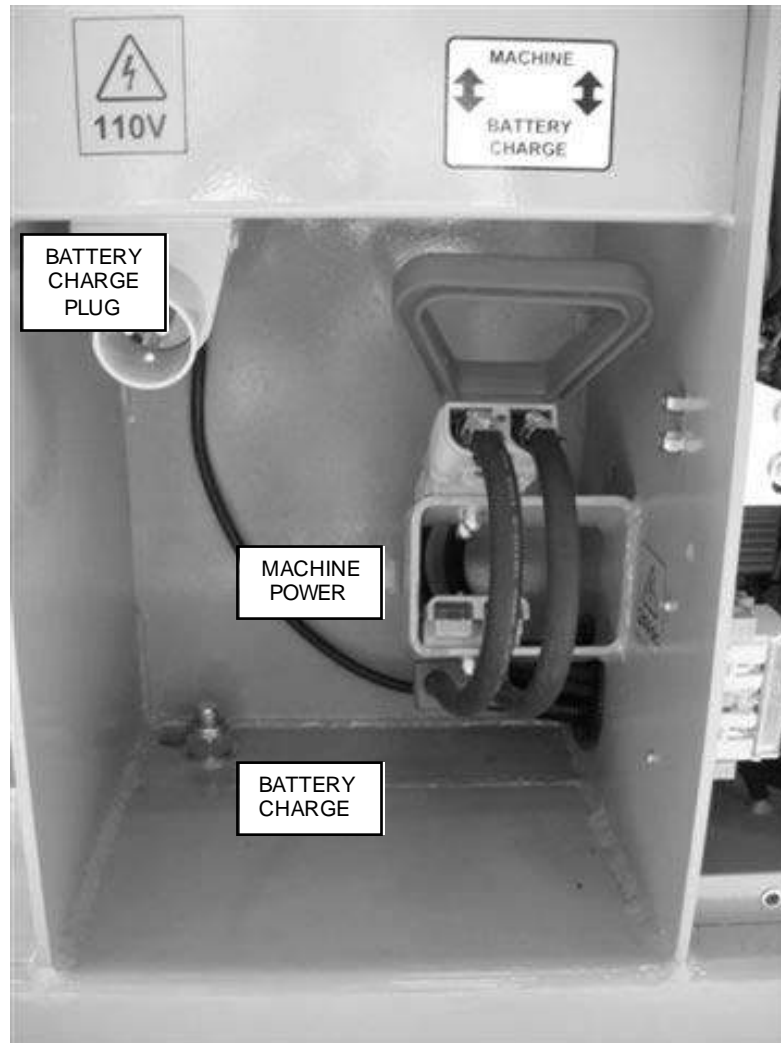

CAUTION!!!

Access to the electrical cabinet is allowed to authorized personnel, only. Tampering with the electrical cabinet will nullify the warranty conditions.

Note: Possibile repairs have to be carried out by the manufacturer or under its authorization.



CAUTION!!!

VERIFY THE ELECTRIC INSTALLATION EARTHING AT ALL TIMES. MAKE SURE THAT THERE IS A SUITABLY DIMENSIONED GROUND FAULT CIRCUIT.



Figura 5



5 USE OF THE MACHINE IN REGULAR WORKING CONDITIONS

5.1 Machine starting

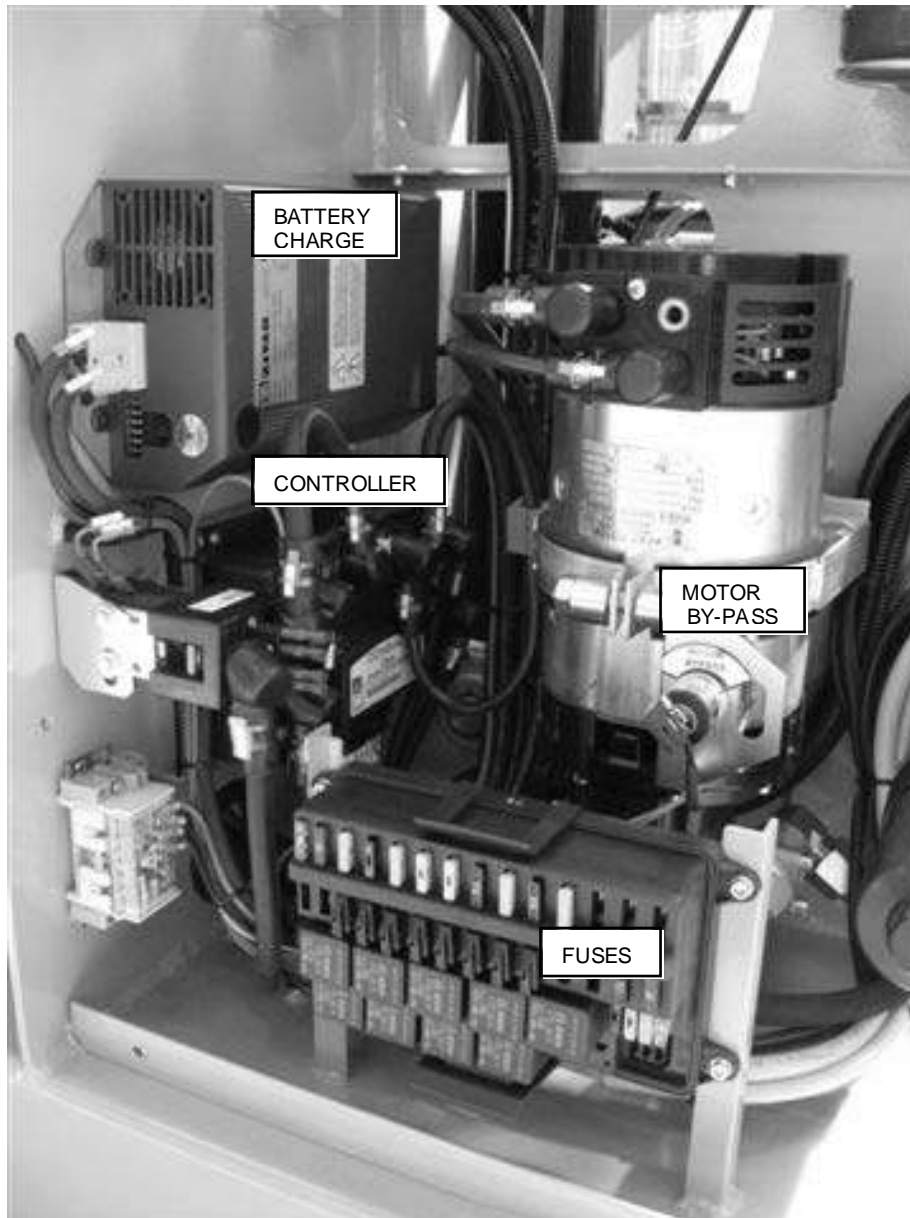
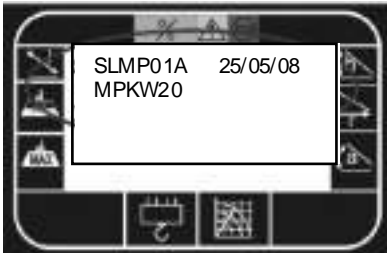
- Put red plug on machine supply socket
- Turn ON key switch on tiller (fig. 2)
- Starting the machine, the system automatically switches on and, for a few seconds, the machine model and the software version is shown (dd.mm.yy= software date of development)



- Afterwards, still for few seconds, it shows the machine working conditions, that is the operative

mode and the possible automatic selection: press  or  to select the operative mode (HOOK, WINCH-W600, JIB_300m, MANIPULATOR MR800.4-10P) and then press

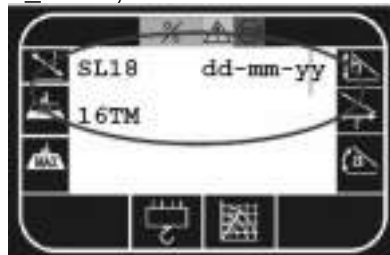
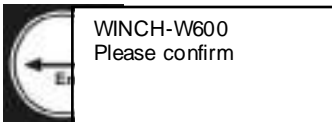

selection.

If you select WINCH-W600 on

the following page you have to choose rope number. Press  or  to select the

number (1 single, 2 double, 3 triple line pulley) and then press  to confirm the selection.

- Now will appear the Main Working Data Reading page

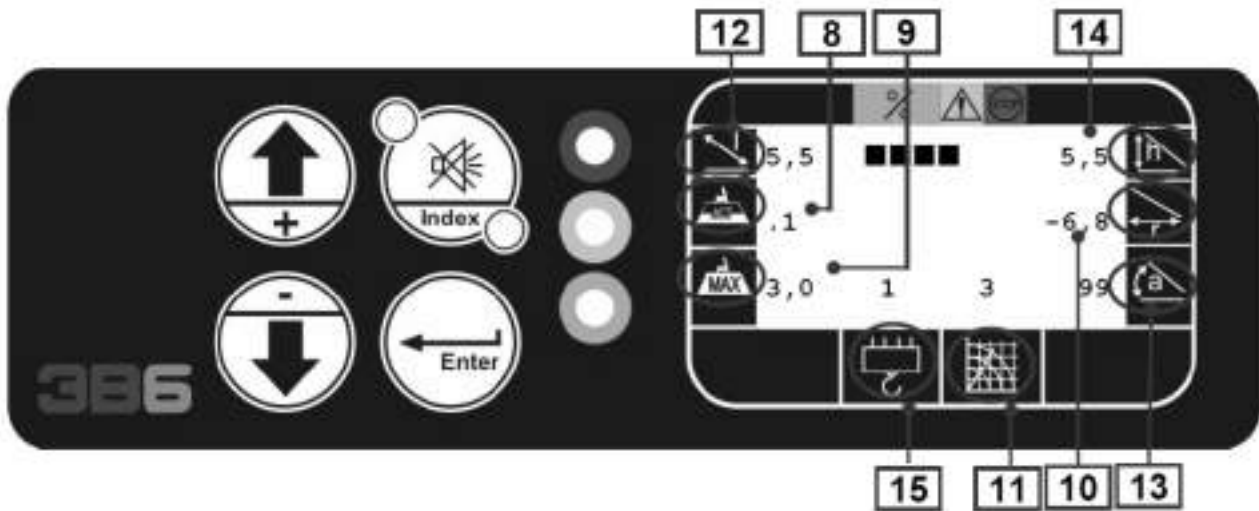

- 8) LIFTED LOAD: Represents the load lifted at this moment Reading in “tonnes”, with a decimal point.
- 9) MAXIMUM ADMITTED LOAD: Represents the maximum load that can be lifted in this position, according to the selected load table. Reading in “Tonnes”, with a decimal point
- 10) WORKING RADIUS: distance from the rotation centre of the turret to the applied load). Reading in “Metres”, with a decimal point
- 11) OPERATIVE MODE: Represents the number of the selected operative mode
- 12) BOOM LENGTH: Represents the actual boom length Reading in “Metres”, with a decimal point.
- 13) BOOM ANGLE: Represents the actual boom angle Reading in “Degrees”.
- 14) HEIGHT FROM THE GROUND: Represents the actual height from the end of the boom to the Ground Reading in “Metres”, with a decimal point.
- 15) PARTS OF LINE: Represents the actual parts of line

NOTE : In case of Imperial Measurement System, the load will be displayed in “Pounds/1000” and the geometric data in “Feet”.

5.2 Machine travel

- Start the machine (see 5.1)
- Press button 5 (fig.2) to start the machine; if you don't use any lever, after 10 seconds you have to press again the button to restart the machine
- Use lever 2 (fig. 2) to move the machine, speed is proportional to lever range movement



CAUTION!!!

Do not operate the machine when the tracks are on the ground.

5.3 Use of the crane

Key switch 3 (fig.2) on LOCAL position:

Start the machine using key switch 3 (fig. 2) and then use the valve bank levers to carry out the moves indicated

Key switch 3 (fig.2) turned to REMOTE position:

When the key switch is in this position, the radio remote control is activated:

- Close the valve bank cover and be sure the red safety microswitch is locked
- Start the radio remote control pushing button 1 (fig.3)
- Use the uniaxial analogical joysticks to operate the crane

5.4 Use of by-pass

- 1- CRANE BY-PASS: Keep turned the key switch 4 (fig.1) and at the same time use valve bank lever



Use by-pass only for emergency situation, pay attention because there is danger of machine turnover!!!

- 2- MOTOR BY PASS: turn on the key switch inside the left compartment to start the electrical motor.

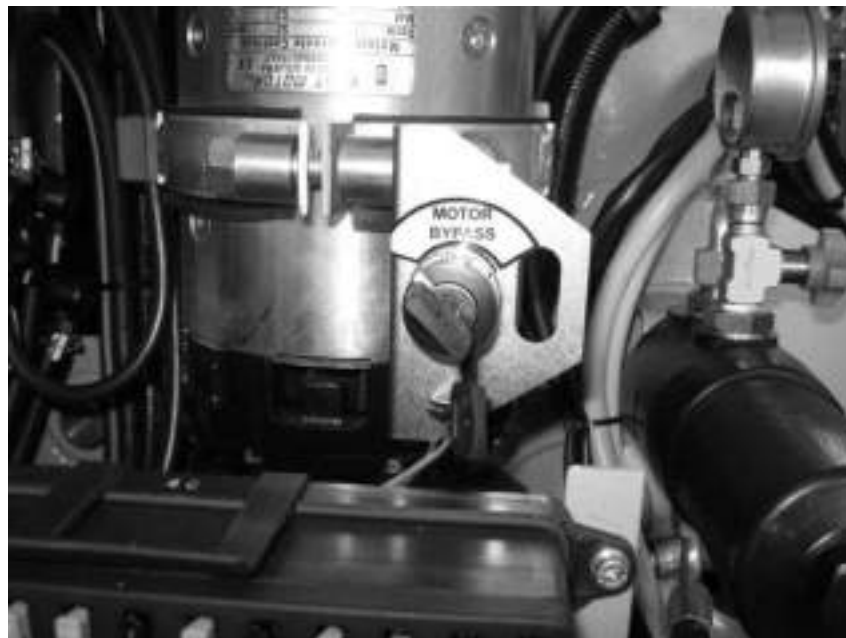

5.5 Alarm

If necessary on the display will appear a flashing alarm code to help you about machine working condition.

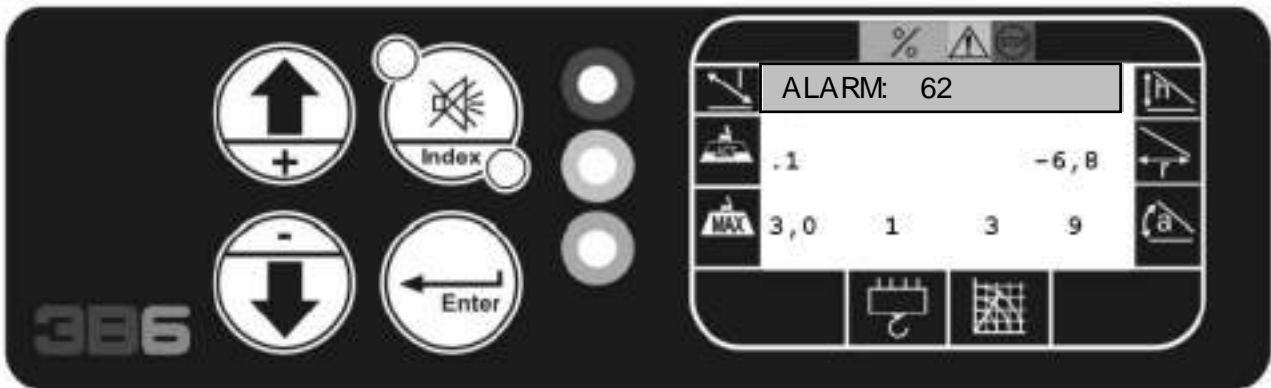

ALLARM / WARNING	ACTION
02- Block due to boom minimum angle	→ Boom up
03- Block due to boom max angle	→ Boom down
04- Block due to boom minimum extension	→ Telescope out
05- Block due to boom max extension	→ Telescope in
08- Back side pressure transducer disconnected	→ Check pressure transducer wiring
09- Back side pressure transducer short-circuited	→ 1° Check fuses >2° replace it
10- Rod side pressure transducer disconnected	→ Check pressure transducer wiring
11- Rod side pressure transducer short-circuited	→ 1° Check fuses >2° replace it
80- Up/down boom lever disconnected	→ Check wiring
81- Up/down boom lever short-circuited	→ Check fuses
82- Telescope in/out lever disconnected	→ Check wiring
83- Telescope in/out lever short-circuited	→ Check fuses
84- Rope up/down lever disconnected	→ Check wiring
85- Rope up/down lever short-circuited	→ Check fuses
22- Emergency push button held down	→ Reset the machine emergency push button
30- By pass on	
62- Radio Remote Control off	→ Turn on radio remote control or turn key switch to LOCAL position
90- Block due to rope up	→ Unwind the rope or telescope in
91- Block due to rope down	→ Wind the rope
120- Canbus Timeout ACQ	→ Call service
121- Guasto interno scheda ACQ	→ Call service

5.6 Danger of turnover

Two safety systems are installed in the machine in order to avoid overtaking maximum allowed SWL:

- WINCH LOAD LIMITER: to avoid uplifting a bigger weight than that of maximum rope SWL
- MOMENTUM LIMITER: to limit uplifting maximum momentum SWL X WORKING RADIUS

Despite these devices, the operator has always to check compatibility between load and SWL diagram you can find on every machine.



Limiter warns every time momentum limit is reached. Danger is indicated through visual and acoustic alarms. While working with remote control, the 3-coloured flashing light must be always visible by the operator. In this way he can always see load conditions.

In case the operator does not pay attention to safety warnings while the machine is lifting a load from the ground, the rear part of the machine may be uplifted and consequently capsized. See pictures below.



It's forbidden to hook electric winch for lifting.

The limiter is not designed to intervene with this application. Not following this specification the manufacturer declines any responsibility in case of damage or injury and the warranty void.

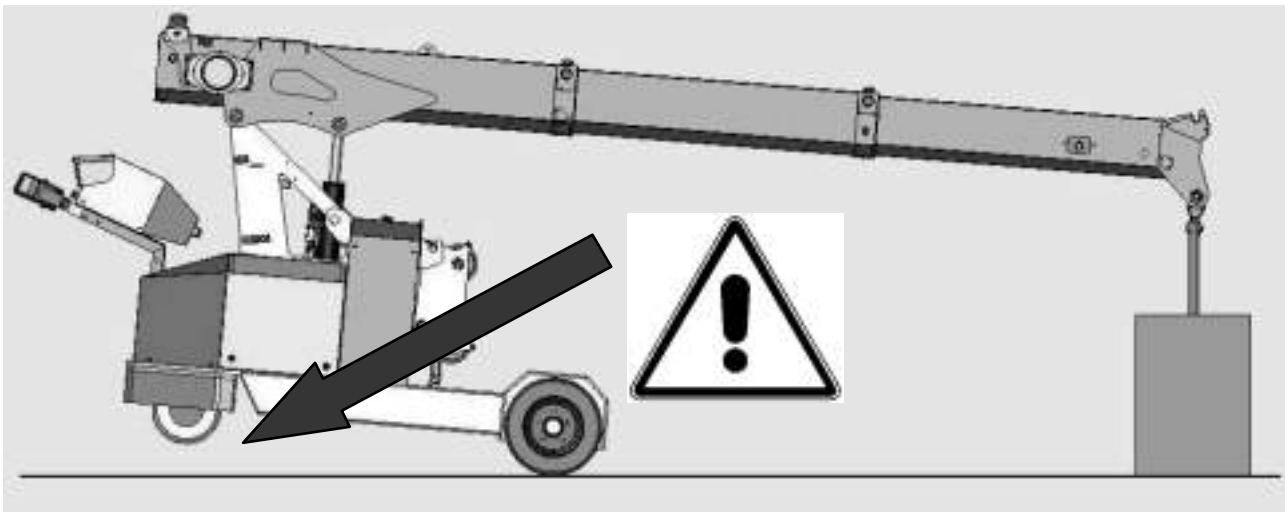

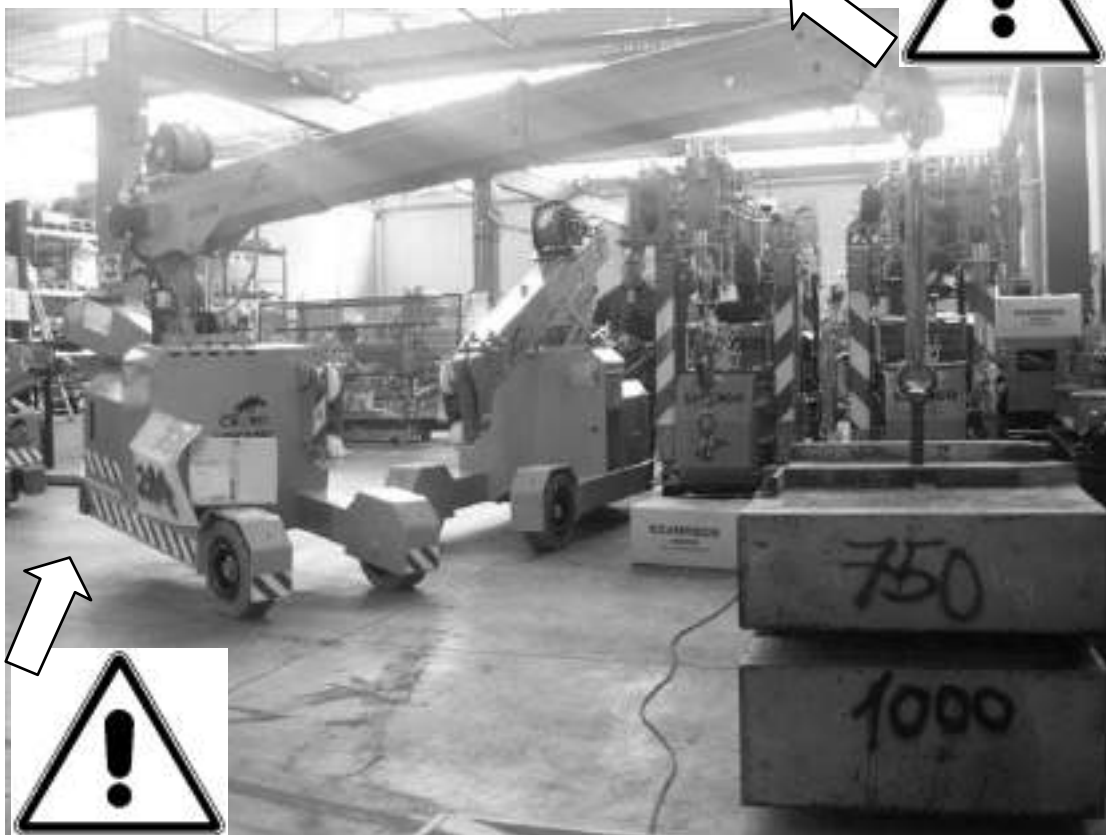

6 HANDLING AND TRANSPORT

Every machine has two anchor points in order to lift and position the machine by means of a yard crane. There is a label like below in the point of lifting.

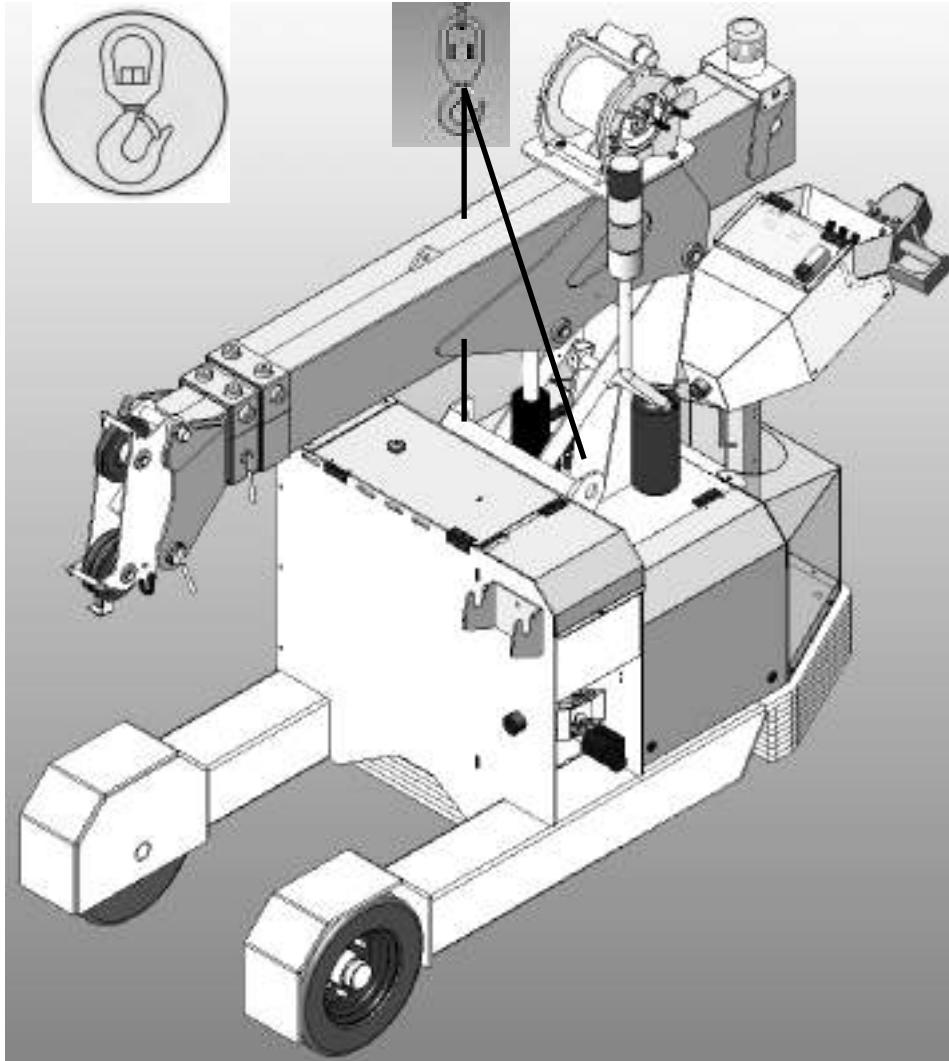

Lifting and transport

7 TROUBLESHOOTING

7.1 Alarms of battery charger model BC1

IN CASE OF ALARM, THE BATTERY CHARGER STOPS DELIVERING CURRENT AND THE LED STARTS FLASHING

State	Alarm	Description (action)
Flashing GREEN	Timeout	Phase 1 exceeding the duration limits allowed – check the battery capacity
Flashing RED-YELLOW	Battery current	Loss of control of the output current – damage to the control logic
Flashing RED-GREEN	Battery voltage	Non-complying battery (check the nominal voltage) or loss of control of the output current (damage to the control logic)
Flashing RED-YELLOW-GREEN	Thermal alarm	Overheating of the semiconductors – check the fan operation
Flashing YELLOW-GREEN	Selection	An unused configuration has been selected – check the key switch position

7.2 Alarms of battery charger model NG1

IN CASE OF ALARM, THE BATTERY CHARGER STOPS DELIVERING CURRENT, THE LED STARTS FLASHING AND AN ACOUSTIC SIGNAL IS GIVEN

State	Alarm	Description (action)
Flashing RED	Presence of batteries	Non-complying or disconnected batteries
Flashing YELLOW	Thermal probe	Thermal probe disconnected or outside the operational range
Flashing GREEN	Timeout	Phase 1 and/or phase 2 exceeding the duration limits allowed – check the battery capacity
Flashing RED-YELLOW	Battery current	Damage to the control logic
Flashing RED-YELLOW	Battery voltage	Loss of control of the output current – battery disconnected or damage to the control logic
Flashing YELLOW-GREEN	Selection	An unused configuration has been selected – check the key switch position
Flashing RED-YELLOW-GREEN	Thermal alarm	Overheating of the semiconductors – check the fan operation

7.3 Alarms battery level and controller MDI

ALARM CODE	DESCRIPTION	CHECK
AL 00	BATTERY LOW	Get the battery charged. If it doesn't work, measure with a voltmeter the battery voltage and compare it with the value in the BATTERY VOLTAGE parameter. If they are different adjust the value of the ADJUST BATTERY function.
AL 30	VMN LOW	Motor internal connections (ohmic continuity)-Motor power cables connections-Motor leakage to truck frame - If motor phases windings/cables have leakages towards truck frame-Motor connections-That the LC power contact closer properly, with a good contact > If no problem are found on the motors, the problem is inside the controller.
AL 31	VMN HIGH	Motor internal connections (ohmic continuity)-Motor power cables connections-Motor connections-That the LC power contact closer properly, with a good contact > If no problem are found on the motors, the problem is inside the controller.
AL 37	CONTACTOR CLOSED	It is suggested to verify the power contacts of LC; to replace the LC is necessary.
AL 38	CONTACTOR OPEN	The wires to the LC coil are interrupted or not connected, so check the coil related harness. It could be also a problem of the contact in the LC that is not working (does not pull-in), try replacing the LC.
AL 42	AUX DRIVE SHORTED	Check if there is a short or a low impedance pull-down between NEB (CNA#31 in AmpSaab, CNA#4 in AmpSeal) and -BATT. The driver circuit is damaged in the controller, which has to be replaced.
AL 43	WRONG SET BAT	Check that the controller SET BATTERY parameter value matches the battery nominal voltage.
AL 51	TILLER OPEN	At the next travel request the warning disappear.
AL 53	STBY I HIGH	This type of fault is not related to external components so, when it is present, it is necessary to replace the controller-Check that the TESTER MENU / BATTERY VOLTAGE parameter shows same value as the battery voltage measured with a voltmeter. If it is does not match, then do a "ADJUST BATTERY" function-Replace the battery.
AL 60	CAPACITOR CHARGE	There is an external load in parallel to capacitor bank, which sinks current from the controller capacitors precharging circuit, thus preventing the caps from charging. Check if a lamp or a dc/dc converter or a auxiliary load is placed in // to capacitor bank-The charging resistance is opened; insert a power resistance across line contactor power terminals; if the alarm disappears, it means the controller internal charging resistance is damaged-The charging circuit has a failure, inside the controller-There is a problem in the controller power section.
AL 62	HIGH TEMPERATURE	Improve the air cooling of the controller. If the alarm is signalled when the controller is cold, the possible reasons are a thermal sensor failure or a failure in the logic card. In this case, it is necessary to replace the controller.
AL 65	MOTOR TEMPERAT	Check the thermal sensor inside the motor (use the MOTOR TEMPERATURE reading in the TESTER menu); check the sensor ohmic value and the sensor wiring. If the sensor is OK, improve the air cooling of the motor. If the warning is present when the motor is cool, then the problem is inside the controller.
AL 67	CAN BUS KO	This alarm could be caused by a canbus malfunctioning, which blinds master-slave communication Otherwise the problem is inside the logic, replace the controller.
AL 74	DRIVER SHORTED	Check if there is a short or a low impedance pull-down between NMCC (CAN#17 in AmpSaab, CAN#12 in AmpSeal) and -BATT-The driver circuit is damaged in the controller, which has to be replaced.
AL 76	COIL SHORTED	The typical root cause for this error code to be displayed is in the harness or in the load coil. So the very first check to carry out concerns connections between controller outputs and loads. In case no failures/problems have been found externally, the problem is in the controller, which has to be replaced.
AL 79	INCORRECT START	A travel demand active at key on-Presence man sensor active at key on.Check the wirings. Check the microswitches. It could be also an error sequence made by the operator. A failure in the logic is possible too; so when all of the above conditions were checked and nothing was found, replace the controller.
AL 80	FW+BW	Check the wiring of the Fwd and Rev travel demand inputs (use the readings in the TESTER to facilitate the troubleshooting). Check the microswitches for failures. A failure in the logic is possible too. So, when you have verified the travel demand switches are fine working and the wiring is right, it is necessary to replace the controller.
AL 82	ENCODER ERROR	Check both the electric and the mechanical encoder functionality, the wires crimping-Check the encoder mechanical installation, if the encoder slips inside its compartment raising this alarm condition-Also the electromagnetic noise on the sensor bearing can be a cause for the alarm. In these cases try to replace the encoder-If the problem is still present after replacing the encoder, the failure is in the controller.
AL 85	VACC NOT OK	Check the mechanical calibration and the functionality of the potentiometer.
AL 86	PEDAL WIRE KO	Check the voltage on NPOT and the potentiometer connections.
AL 52	PUMP I=0 EVER	Check the motor connection, that there is continuity. If the motor connection is opened, the current cannot flow, so the test fails and the error code is displayed.-If everything is ok for what it concerns the motor, the problem could be in the current sensor or in the related circuit.
AL 90	PUMP INCORRECT START	A hydraulic function demand active at key on-Deadman sensor active at key on-Check the wirings. Check the microswitches. It could be also an error sequence made by the operator. A failure in the logic is possible too; so when all of the above conditions were checked and nothing was found, replace the controller.
AL 93	EVP DRIVER SHORTED	Check if there is a short or a low impedance between the negative of the coil and -BATT. Otherwise the driver circuit is damaged and the controller must be replaced.

7.4 AUTO DIAGNOSTIC SLIM

The LMI is equipped with an auto diagnostic system which is able to detect faulty pressure transducers, or boom angle/length sensors, broken cables or internal electronic faults.

When an alarm occurs, the SLIM puts itself in a safe condition stopping the dangerous movements and at the same time the display shows an alarm message on the first row.

According to the alarm code and message, it will be possible to identify the fault.

See LMI manual on attached.

AUTO DIAGNOSTIC- System internal working conditions monitoring Geometric data and load data

These readings show on some pages the internal status of the system which is very useful when a fault occurs.

Starting from the main working data page press **twice** the  button:

The display will show the **first control page**, giving **geometric data and main cylinder differential pressure summary**.

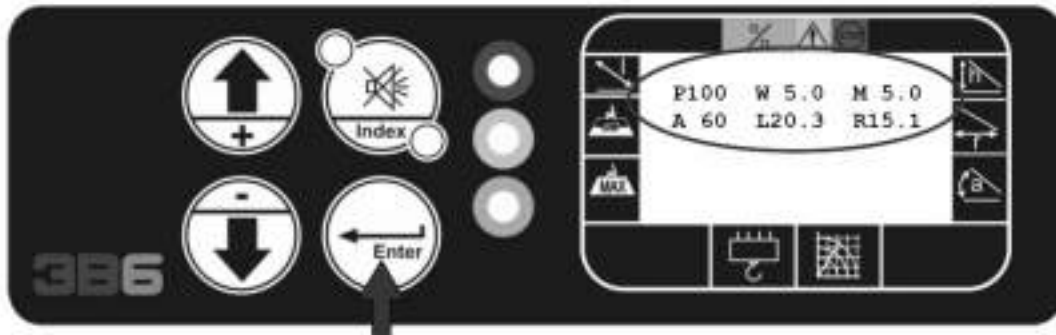

This page is displayed for 30 seconds; after which, it returns to the normal working condition page.

The displayed parameters are as follows:

- P : Main cylinder differential pressure in Bar;
- W : Lifted load weight in Tonnes (Pounds/1000 if Imperial Measurement System is used);
- M : Maximum admitted load in present position in Tonnes (Pounds/1000 if Imperial Measurement System is used)
- A : Actual angle in Degrees;
- L : Actual boom length in Meters (in Feet if Imperial Measures System is used);
- R : Radius from turret rotation centre in Meters (in Feet if Imperial Measurement System is used)

8 STANDAR OPERATOR MAINTENANCE

8.1 Ordinary Maintenance

Ordinary maintenance can be carried out independently by the machine operator. A regular a careful maintenance preserves the machine and extends its life cycle. Damages and malfunctions often require higher costs in terms of time and money than those faced for a correct maintenance. The basic preset deadlines of extraordinary maintenance are at 500 and 1000 working hours.

Washing

- The equipment can be washed with detergents.
- Do not use degreasers and/or acid detergents.



DO NOT WASH THE MACHINE WITH A HIGH-PRESSURE WATER JET CLEANER

Lubrication



Lubrication is to be carried out only when the machine is at a standstill.

RECOMMENDED LUBRICANTS:

LITHIUM-BASED LUBRICANTS for temperatures ranging from -20°C to +50°C

The areas to be lubricated are equipped with a special lubricating nipple and are indicated with a sticky label:

- Cylinders
- Pivots
- Winch
- Boom extensions



Hydraulic oil

Top up or replace only with the following recommended oil:

**OIL ROLOIL HLD 46 AI
o equivalent, viscosity index 46 cst (ISO VG 46).**

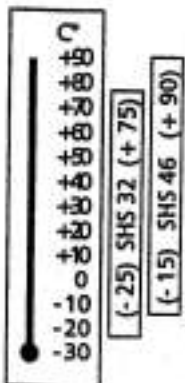

CAUTION!

If the machine works in a very cold climate where the temperature falls much below the freezing point, use an oil with VG32 viscosity index.



Please dispose of the used engine oil in a manner that is compatible with the environment. We suggest you take it in a sealed container to your local service station for reclamation. Do not throw it in the trash, pour it on the ground or down a drain.

Welding

Welding must be carried out by authorized personnel, only, since some electrical devices have to be disconnected during these operations..

8.2 Battery recharging

- Connect the feeding cable by means of the suitable plug 220V blue 110V yellow
- Connect the red plug to battery charge plug (fig. 4)
- For the batteries to recharge, it isn't necessary that the machine is started or that the battery switch is on the ON position. When the connection is done, the battery charger fan starts
- When recharging the batteries, place the machine in a well-aired place in order to avoid explosions due to the explosive gases generated by the batteries
- The battery charger starts and stops automatically



It is recommended to avoid run the batteries completely down otherwise the recharging time would remarkably extended thus implying the risk of damaging the batteries. Once the machine is stabilized, connect it to the power supply as soon as possible and operate under voltage.



At the end of the working day or when the machine will be laid up for long periods, remember to disconnect the battery switch in order to avoid run the batteries completely down.

Battery charger

- To avoid overheating, check that all the cooling clefts are not clogged.
- Protect the battery charger from possible water sprays.
- Make sure that the available power supply corresponds to that indicated on the battery charger identification plate.
- If an extension or a multiple jack are used, make sure they are suitable to the overall voltage required.
- Turn off the power supply before connecting or disconnecting plugs.
- In case of lead-acid storage battery charging **WARNING!!!:EXPLOSIVE GASES >** keep flames and sparks away. Battery must be located on a ventilated area.
- Do not use the battery charger to charge batteries of hot-air engine cars.
- Only rechargeable batteries can be charged.
- Check battery voltage is the same indicated on battery charger identification plate
- Don't try to repair the battery charger: the cover opening may cause danger of electrical shock
- If the battery charge does not work correctly, unplug it immediately from the main and from the battery and apply to the seller.

Battery

- Always wear individual protective clothing such as safety glasses, gloves, etc. when performing battery maintenance.
- Never add acid to the battery.
- Do not expose to extreme heat or open flame.
- Make sure electrolyte covers are close
- Keep the battery clean and dry.

8.3 How to increase the battery lifetime

Charging

- Re-charge battery after each usage.
- Verify electrolyte level is over the plates.
- Tighten vent caps before charging;
- Do not interrupt charge cycle;
- Never charge a frozen battery.
- Perform re-charging in ventilated areas only.

Topping-up

- Add water only after have completely re-charged the battery;
- Never let the electrolyte level falls below the plates;
- Use distilled water or water with low mineral content.

Cleaning

- Nothing has to fall inside the battery.
- Clean only with water, then dry.
- Protect cables with anti-rust products.

Storing

- Completely charge the battery before storing.
- Store batteries in a cool, dry location.
- Avoid direct exposure to heat sources such as radiators or heaters
- While storing, charge batteries every six weeks.

8.4 General warnings for maintenance activity

- ❖ The machine must be parked on a level surface.
- ❖ Perform maintenance when the machine is cold.
- ❖ Rest the machine on some blocks, it cannot be kept lifted.
- ❖ Rest all disassembled components on solid surfaces and place them so that they cannot fall in case hydraulic pressure should fall. Tutte le parti rimosse devono essere appoggiate su superfici solide e posizionate in modo che non cadano se la pressione idraulica decade
- ❖ All lifting devices must comply with the rules in force.
- ❖ If possible, do not climb on the machine but use suitable lifting platforms.
- ❖ Wear individual protective clothing (D.P.I.) such as gloves, glasses, etc.).

- ❖ Do not wear jewels or things that can be lost while working
- ❖ Pay attention not to damage hydraulic pipes or electrical cables during maintenance operation;
- ❖ Use suitable tools only.

8.5 Extraordinary maintenance



Extraordinary maintenance shall be carried out by authorized workshops only.

The following timetable shows the maintenance operation schedule. Extraordinary maintenance shall be carried out every 500 and 1000 working hours. The operator shall apply the machine servicing before time is elapsing, otherwise the warranty will become void.

COMPONENT PART	TYPE OF CHECK	WEEKLY	500 ore	1000 ore	YEARLY	
1. FRAME & STRUCTURE						
• <i>Main frame</i>	<i>cricks and wear</i>	X		X	COMPLETE CHECK OF THE MACHINE INCLUDED LOADING TESTS	
• <i>Crane pillar and extension</i>	<i>cricks and wear and greasing</i>	X		X		
• <i>Pin</i>	<i>cricks, wear, greasing and tightening</i>		X	X		
• <i>Wheels</i>	<i>state of repair and wear</i>		X	X		
• <i>Frame Fixing Bolts</i>	<i>cricks, wear and tightening</i>		X	X		
2. LIFTING SYSTEM						
• <i>Lifting hook</i>	<i>cricks and wear</i>	X	X	X		
• <i>Winch rope</i>	<i>cricks and wear</i>	X	X	X		
3. HYDRAULIC SYSTEM						
• <i>Pump</i>	<i>oil leakage, noise</i>		X	X		
• <i>Oil tank</i>	<i>oil level, oil condition</i>		X	X		
• <i>Hydraulic oil</i>	<i>changing</i>			X		
• <i>Filter</i>	<i>changing</i>			X		
• <i>Cylinders and valves</i>	<i>oil leakage</i>			X		
• <i>Valve bank</i>	<i>oil leakage</i>			X		
• <i>Flexible pipes</i>	<i>oil leakage and wear</i>		X	X		
• <i>Hydraulic pressure</i>	<i>check</i>			X		
4. ELECTRICAL PARTS						
• <i>All panel</i>	<i>oxidation</i>		X	X		
• <i>Power line</i>	<i>state of repair and wear</i>			X		
• <i>Battery charge</i>	<i>state and functioning</i>		X	X		
• <i>Batteries</i>	<i>electrolyte level</i>	X		X		
• <i>Electrical engine</i>	<i>state and functioning</i>			X		
• <i>Pressure detector</i>	<i>functioning</i>		X	X		
• <i>Angle sensor</i>	<i>functioning</i>		X	X		
5. SAFETY DEVICES						
• <i>Emergency Push Button</i>	<i>functioning</i>	X		X		
• <i>Signals on the switchboard</i>	<i>functioning</i>		X	X		
6. ACCESSORIES						
• <i>Winch</i>	<i>greasing</i>		X	X		
7. WARNING PLATES						
• <i>"CE" mark, identification plate of the crane and of the accessories</i>	<i>presence and visibility</i>		X	X		
• <i>Labels</i>	<i>presence and visibility</i>		X	X		

9 SERVICING FORMS

9.1 Introduction

According to the European Directive 2006/42/CE the machine's operator has to create and regularly update a maintenance register to record:

- extraordinary and special maintenance operations,
- 500-working hour warrant-compulsory checks on structural component parts,
- 1000-working hour compulsory checks carried out by the controlling authority.

ORMET SPA has prepared a model of this register for you. Ordinary maintenance will be done in careful accordance with the instructions provided in the maintenance manual. Extraordinary maintenance, e.g. the substitution of a component part or the repair of a safety device, are to be made by trained personnel or at an authorized workshop.

It is very important to take care of and update the register, in order to keep the machine always in perfect safety and performance conditions, and to prove its regular functioning in case of inspection by controlling authorities.

Instruction reported in this manual and in the register have been prepared under the regulations and standards in force at the time of first operating the machine. Further and new regulations could modify your obligations: in this case, ORMET SPA will be at your disposal for further explanation.

In the register you can record:

- Quite important faults and the relevant repairs
- Periodical checks
- Change of structural, hydraulic and safety component parts
- Change of property



This register and the operating manual are an integral part of the machine and must always be kept with the machine, even in case of sale.

This register includes:

- Use and maintenance
- Compulsory periodical checks (every 6/12/18/24 months)
- Forms to record periodical checks and maintenance operations
- Forms to record reports on maintenance and servicing, (with progressive record number and enclosures)
- Form for the conveyance of information in case of sale, transfer of property or change of operator

9.2 Events that relieve the manufacturer from its liability

THE MANUFACTURER SHALL BE RELIEVED FROM ANY RESPONSIBILITY OR LIABILITY IN CASE OF:

- Improper use of the machine
- *Tampering with the machine or with its component parts*
- *Machine used by not authorized personnel*
- *Serious maintenance shortage*
- *Partial or complete non-observance of instructions*
- *Non-topping up of lubrication system in the periodical checks and non-filling in of relevant reports*
- *Non-performance of periodical checks*
- *Use of non original spare parts (spare parts not recommended by the manufacturer)*
- *Non authorized modifications and repairs*
- *Exceptional events.*

9.3 Maintenance and servicing register

The following forms have been prepared in order to facilitate the operator to record and prove the maintenance and servicing carried out on the machine.



| Filling in the forms regularly is strongly recommended.



10 ENCLOSURE

10.1 Summarizing list of maintenance and servicing interventions

<i>DATE</i>	<i>TIPE OF INTERVENTION</i>	<i>N° REPORT</i>	<i>OPERATOR SIGNATURE</i>



10.2 Detailed Forms On Servicing And Maintenance

Report on intervention N° _____ date: ____/____/____

(reports must be enclosed to the relevant intervention form with their number)

Machinery/appliance type: **Serial Number:**

SERVICING WORKSHOP

Workshop:

Town: postcode:

address: n°

DESCRIPTION

STAMP AND SIGNATURE

.....

Report on intervention N° _____ date: ____/____/____

(reports must be enclosed to the relevant intervention form with their number)

Machinery/appliance type: **Serial Number:**

SERVICING WORKSHOP

Workshop:

Town: postcode:

address: n°

DESCRIPTION

STAMP AND SIGNATURE

.....



10.3 Form For The Conveyance Of Information

CONVEYANCE OF INFORMATION CONTAINED IN THE MANUAL
--

Date:

The undersigned:

..... postcode:

address: n°

Telephone:

STATE:

- to have received and well understood the information on functioning of the machine
- to have received the operating and maintenance manual and to have well understood its content

From Mr:

..... postcode.

address: n°

Telephone:

AND TAKES ON THE RESPONSIBILITY TO CONVEY THE SAME INFORMATION AND THE MACHINE MANUAL TO THE NEXT OPERATOR OR OWNER.

FAITHFULLY
Previous operator

FAITHFULLY
Next operator

.....

.....

10.4 SLIM manual



10.5 Radio remote control manual



10.6 Hydraulic scheme

