

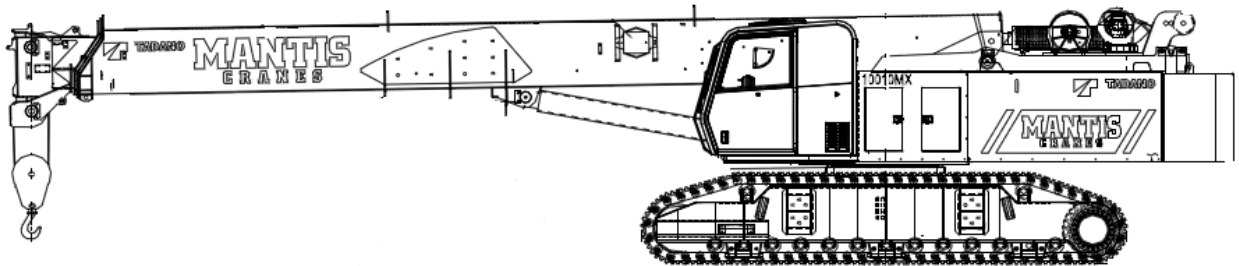

MANTIS CRANES

Operating and Maintenance Manual 10010MX

50 TON/45 METRIC TON DIESEL POWERED TELESCOPIC BOOM CRAWLER CRANE



Crane Serial No: _____

Manufacturer:
Tadano Mantis Corporation
1705 Columbia Ave.
Suite 200
Franklin, TN 37064
Phone: (615) 794-4556
Fax: (615) 790-6803

TABLE OF CONTENTS

PREFACE	VI
SECTION 1. OVERVIEW	1
1.1 Overview	1
1.1.1 Service Conditions	1
1.2 Directional References	2
1.2.1 Crane Operations	2
1.2.2 Travel Operations	2
1.3 Boom Load Charts	3
1.3.1 Capacity Limits and General Conditions	4
1.4 Technical Data	6
1.4.1 Standard Crane and Equipment	6
1.4.2 Boom	7
1.4.3 Boom Telescoping & Elevating Systems	7
1.4.4 Boom Head	7
1.4.5 Rated Capacity Indicator	7
1.4.6 Anti-Two Block	7
1.5 Superstructure	8
1.5.1 Frame	8
1.5.2 Engine	8
1.5.3 Operator's Cab	8
1.5.4 Instrumentation and Accessories	8
1.5.5 Control	8
1.5.6 Counterweight	9
1.5.7 Hoist Winches	9
1.5.8 Safety Equipment	9
1.5.9 Electrical Equipment	10
1.5.10 Swing	10
1.5.11 Fuel System	10
1.5.12 Hydraulic System	10
1.6 Undercarriage	10
1.6.1 Carbody	10
1.6.2 Side Frames	10
1.6.3 Travel	10
1.7 Optional Equipment	11
1.7.1 Boom Attachments	11
1.7.2 Hydraulic	11
SECTION 2. SAFETY INSTRUCTIONS	12
2.1 Basic Safety Rules	13
2.2 Instructions for Crane Operation	13
2.3 Crane Application in Accordance with the Intended Use	14
2.4 Lifting Capacities of Crane	14
2.5 Safety Devices	15
2.6 Before Crane Operation	15
2.7 Placement of Crane	16
2.8 Counterweight	16
2.9 Rigging and Signaling	17
2.9.1 Recommended Hand Signals	18
2.10 Lifting Operation	21
2.11 Operation Near Power Lines	25
2.11.1 Grounding the Crane	28
2.11.2 Inspection Measures	28
2.12 Operation In Wind and Lightning	29
2.13 Operation Near Pipelines	30
2.14 Operation In Cold Weather	30
2.15 Leaving the Crane Out of Service	30

TABLE OF CONTENTS

2.16	Potential Causes of Accidents -----	30
2.16.1	<i>Operation Faults That May Cause Accidents</i> -----	30
2.16.2	<i>Servicing Faults That May Cause Accidents</i> -----	31
2.17	Fire, Smoke, Inflammation and Explosion Hazards -----	32
SECTION 3. OPERATING INSTRUCTIONS -----		37
3.1	Location of Warning and Instruction Markings (US) -----	37
3.2	Location of Warning and Instruction Markings (Export) -----	42
3.3	Location of Cab Warning and Instruction Markings -----	45
3.4	Load Moment Indicator (AML) -----	52
3.5	Dash/Control Panels -----	52
3.6	Cab Display -----	55
3.6.1	<i>Operating Pages</i> -----	56
3.6.2	<i>Service Pages</i> -----	57
3.6.3	<i>Display Icons</i> -----	58
	<i>Display Gauges</i> -----	63
3.7	Switch Panel -----	65
3.8	Engine LEDs -----	67
3.8.1	<i>Startup Procedure</i> -----	67
3.9	Ignition Acc./Off/On/Start -----	68
3.10	Foot Throttle -----	69
3.11	Swing Right/Left Controls (LH Joystick) -----	70
3.12	Swing Brake Pedal -----	70
3.13	Swing Brake Switch -----	71
3.14	Telescope Out/In Controls (LH Joystick) -----	72
3.15	Auxiliary Winch Control -----	72
3.16	Main Winch/Boom Hoist Controls (RH Joystick) -----	73
3.17	Travel Controls -----	74
3.18	Auxiliary Equipment Controls -----	77
3.19	Other Operator Controls -----	79
3.20	Emergency Back Up System -----	79
3.20.1	<i>Emergency Back Up System Procedure</i> -----	79
3.21	Battery Cutoff Switch -----	80
3.22	Operation -----	81
3.22.1	<i>Alarm Systems</i> -----	81
3.22.2	<i>Walk-Around Inspection</i> -----	81
3.22.3	<i>Air Intake System</i> -----	81
3.22.4	<i>Engine Cooling System</i> -----	81
3.22.5	<i>Electrical System</i> -----	82
3.22.6	<i>Fuel and Lube Systems</i> -----	82
3.23	Pre-Start Checks -----	82
3.24	Electric Starting -----	83
3.24.1	<i>Starting With Jumper Cables</i> -----	84
3.24.2	<i>After Starting the Engine</i> -----	85
3.24.3	<i>Engine Stopping</i> -----	85
3.24.4	<i>After Stopping the Engine</i> -----	86
3.24.5	<i>Horn</i> -----	86
3.25	Cold Weather Operation -----	87
3.25.1	<i>Fuel Selection</i> -----	87
3.25.2	<i>Fuel Heaters</i> -----	87
3.25.3	<i>Fuel Filters</i> -----	87
3.25.4	<i>Engine Compartment Temperature</i> -----	87
3.26	Winch Operation -----	88
3.26.1	<i>Main Winch</i> -----	88
3.26.2	<i>Auxiliary Winch</i> -----	88

TABLE OF CONTENTS

3.26.3	Winch Warm-Up Procedure	88
3.26.4	Anti-Two-Block Control	88
3.26.5	Overload Control	89
3.26.6	Last Wrap Control	89
3.27	Boom Controls	90
3.27.1	Boom Hoist	90
3.27.2	Boom Telescope	90
3.27.3	Anti-Two-Block (A2B) Control	90
3.27.4	Overload Control	90
3.27.5	Backward Stability Control	90
3.27.6	Swing Controls	91
3.27.7	Dual Mode Swing Valve	91
3.27.8	Swing Park Brake	91
3.27.9	Swing Service Brake	91
3.28	Travel Controls	92
3.28.1	Tracks Forward/Reverse	92
3.28.2	Tracks Extend/Retract	92
3.29	Auger Operation (optional)	93
3.29.1	Digging with the Auger	93
3.29.2	Stowing the Auger	93
3.29.3	Tool Circuit Operation	93
3.30	Reeving	94
3.31	Preparation for Shipping	96
3.32	Counterweight Removal/Installation	96
3.32.1	Installing the Counterweight	96
3.32.2	Removing the Counterweight	97
3.33	Jib/Extension Removal/Installation	98
3.33.1	Removing the Jib and Extension	99
3.33.2	Installing the Jib and Extension	99
3.34	Extension/Jib Erection & Rigging	100
3.34.1	Erecting and Rigging the Extension	100
3.34.2	Stowing the Extension	102
3.34.3	Erecting and Rigging the Extension and Jib	103
3.34.4	Stowing the Extension and Jib	106
SECTION 4.	MAINTENANCE	109
4.1	Lubrication and Maintenance	109
4.2	Maintenance Intervals	109
4.3	Engine	113
4.3.1	Inspecting Oil Level	113
4.3.2	Changing Oil/ Replacing the Oil Filter	114
4.3.3	Inspecting Hose Clamps of the Charge Air Hoses	114
4.4	Fuel Tank	114
4.4.1	Draining Condensation Water from Tank	114
4.4.2	Cleaning Fuel Strainer in the Filler Cap	114
4.4.3	Draining Condensation Water from Separator	115
4.4.4	Replacing Fuel/Water Separators	115
4.5	Water-Cooled Engine Cooling Systems	115
4.5.1	Coolant Level	115
4.5.2	Draining Coolant	116
4.6	Cleaning the Radiator	116
4.7	Air Cleaner	117
4.7.1	Removing / Installing the Filter Cartridge	117
4.7.2	Filter Cartridge	118
4.7.3	Air Intake Pipes and Hoses	118

TABLE OF CONTENTS

4.7.4	<i>Inspecting Air Inlet Vacuum Switch</i>	118
4.8	Exhaust System	119
4.9	Hydraulic System	119
4.9.1	<i>Inspecting Oil Level</i>	119
4.9.2	<i>Replacing Filter Cartridges</i>	120
4.9.3	<i>Changing Oil</i>	121
4.9.4	<i>Changing Oil Type</i>	121
4.9.5	<i>Hydraulic Fittings</i>	122
4.9.6	<i>Checking Fittings</i>	122
4.9.7	<i>Oil Cooler</i>	122
4.9.8	<i>Maintenance Instructions for Hydraulic Cylinders</i>	122
4.10	Speeds of Hydraulic Functions	123
4.10.1	<i>Speed Set-points of the Hydraulic System</i>	123
4.10.2	<i>Speed Setting Tolerances</i>	123
4.11	Hydraulic System Pressure Checks	123
4.11.1	<i>Hydraulic System Pressure and Flow Settings</i>	124
4.11.2	<i>Hydraulic System Pressure Setting Tolerances</i>	124
4.12	Electrical Equipment	125
4.12.1	<i>Batteries</i>	125
4.12.2	<i>Installing New Batteries</i>	126
4.12.3	<i>Starting the Engine with Jumper Cables</i>	126
4.12.4	<i>Starter</i>	127
4.12.5	<i>Circuit Breaker Panel</i>	127
4.12.6	<i>Lamps and Lights</i>	127
4.13	Rated Capacity Indicator (RCI)	127
4.14	Swing Mechanism	128
4.14.1	<i>Checking Correct Oil Level and Leakage</i>	128
4.14.2	<i>Changing Oil</i>	129
4.14.3	<i>Inspecting the Swing Mechanism</i>	130
4.14.5	<i>Bleeding the Swing Brake</i>	130
4.14.7	<i>Tooth Face Backlash (Swing Motor Gearbox Drive Shaft)</i>	130
4.14.8	<i>Greasing Slew Ring Gear and Pinion</i>	131
4.14.9	<i>Greasing the Slew Ring</i>	131
4.14.10	<i>Checking Slew Ring Fasteners</i>	132
4.14.11	<i>Checking Slew Device for Wear</i>	133
4.15	Winches	133
4.15.1	<i>Checking Winch Oil Level</i>	133
4.15.2	<i>Changing Winch Oil</i>	133
4.15.3	<i>De-commissioning the Winch</i>	135
4.15.4	<i>Inspecting the Winch Brake</i>	135
4.16	Anti-Two Block (A2B) Switch	135
4.17	Travel System	136
4.17.1	<i>Track Drive Reducers</i>	136
4.17.2	<i>Track Tension</i>	136
4.17.3	<i>Extend Beams</i>	136
4.17.4	<i>Undercarriage</i>	136
4.18	Last Wrap Indicator	137
4.19	Winch Rope	137
4.19.1	<i>Inspecting the Rope</i>	137
4.19.2	<i>Cleaning and Lubrication of the Rope</i>	137
4.19.3	<i>Replacing Rope</i>	137
4.19.4	<i>Inspecting Rope Drum</i>	138
4.19.5	<i>Installing New Rope</i>	138
4.19.6	<i>Winch Rope Care</i>	139
4.20	Crane Cabin	139

TABLE OF CONTENTS

4.20.1	Heat, Ventilation, & Air Conditioning -----	139
4.20.2	Air Intake Filter -----	140
4.20.3	Wiper-blade Elements/Washing System -----	140
4.21	Points of Lubrication, Maintenance -----	140
4.21.1	Boom -----	140
4.21.2	Boom Hoist Cylinder -----	140
4.21.3	Hook Block -----	140
4.21.4	Jib and Extensions -----	141
4.21.5	Other Points of Lubrication -----	141
4.22	Lubrication and Filter Specifications -----	141
4.22.1	Lubrication Specification Table -----	143
4.22.2	Filter Specification Table -----	144
4.22.3	Inspection Scheme (Daily, Before Startup) -----	145
4.22.4	Oil / Coolant Level Inspection and Change Scheme -----	146
4.22.5	Inspection and Cleaning Scheme -----	147
4.22.6	Lubricating Scheme -----	148
SECTION 5.	APPENDIX A – LOAD MOMENT INDICATOR -----	149
5.1	General -----	149
5.2	Operating Status Registration & Load Moment Indicator Function Check -----	153
5.3	Alarm and Recovery Operation -----	162
5.4	Other Functions -----	164
5.4.1	Work Range Alarm Function -----	164
5.4.2	TARE Function -----	167
5.4.3	User Adjustment Menu -----	167
SECTION 6.	APPENDIX B – DRUM ROTATION & LAST LAYER INDICATOR -----	171

PREFACE

PREFACE

1. Purpose of this Operating Manual

This operating manual provides vital information that is a prerequisite for working safely with the machine. It is intended primarily for the crane operator and for maintenance specialists. It must be available to the operator and maintenance staff at all times. Thus, the manual must always be kept within easy reach of the operator's workplace (i.e. in the operator's cab).

This manual is an integral part of the vehicle. Before putting your Tadano Mantis crane into operation, please study the manual thoroughly. Familiarize yourself with section 2 "Safety Instructions," as well as the instruction plates mounted on the machine and their meaning. You must also be informed about the arrangement, functions and direction of operation of all the controls before you start up the machine for the first time.

Whenever you work with the crane, be sure to observe the instructions laid down in this operating manual.

2. Manual Organization

Section 1 Overview – describes the 10010MX in general, lists general cautions for safe crane operation, and explains the crane's systems and the way its documentation is organized.

Section 2 Safety –provides information pertaining to the proper use of this equipment.

Section 3 Operation – provides detailed instructions about operation of all systems of this equipment.

Section 4 Maintenance– provides the necessary information to maintain the equipment and troubleshoot faults or errors during operation.

3. Use of this Operating Manual

This operating manual covers the machine model supplied, plus any optional equipment that may be available. To find the information you need, please consult the table of contents. The headline of the corresponding chapter appears in the header of each page. The controls, gauges, and switches installed in the cab (at the operator's place) are mentioned on many pages. The figures shown may differ from the machine model actually supplied. They are still relevant, however.

PREFACE

Safety precautions and recommendations are outlined in this section and are also included in the operation and maintenance instructions given in subsequent sections. Warning labels are also provided on the machine. The cautionary instructions in this manual and on the labels are identified as "DANGER," "CAUTION," or "NOTE."



DANGER indicates an imminently hazardous situation which, if not avoided, will result in death or serious injury.



WARNING indicates a potentially hazardous situation which, if not avoided, could result in death or serious injury.



CAUTION indicates an important operational or maintenance procedure or condition, which, if not strictly observed, can result in damage to machine components or deteriorated machine performance.

It is virtually impossible to anticipate every situation that might present a hazard. The safety precautions given in this manual and on the machine labels are not exhaustive. It is important, therefore, to strictly follow the instructions in this manual and be sensitive to potential dangers in order to prevent bodily injury and damage to the machine.

The contents of this manual must not be copied, distributed, used for purposes of competition, or disclosed to any third party.

Copyright according to the Copyright Act expressly reserved.



OVERVIEW

SECTION 1. OVERVIEW

1.1 OVERVIEW

The Tadano Mantis 10010MX is a diesel-powered, hydraulically operated, telescopic boom crawler crane. Its maximum load capacity is 50 ton at a 10 ft radius (45.4 metric tons at 3m).

The 10010MX is operated from the crane operator's cab. This main operating station provides for operation and monitoring of all crane functions, including winch, boom, swing, and travel controls. All controls for normal crane operations are arranged in the standard configuration for crane operation.

1.1.1 Service Conditions

The 10010MX was designed and built to operate in the following environment conditions:

Condition	Range
Temperature	-4°F (-20°C) to 115°F (46°C)
Altitude	<10800 ft (3300 m)
Wind Speed	Consult load chart provided with crane.

Options are available to extend the extremes of some of these service conditions. Please contact your Tadano Mantis dealer for information regarding these options.

OVERVIEW

1.2 DIRECTIONAL REFERENCES

1.2.1 Crane Operations

When the words “right” and “left” designate direction in craning operations, they refer to the right- or left-hand side of the 10010MX as viewed from the operator’s cab, no matter which direction the cab is facing.

1.2.2 Travel Operations

When the words “right” and “left” designate direction in travel operations, they refer to the right or left hand side of the 10010MX as viewed with the operator cab facing forward. If the cab is facing backward (boom over the drive end of the undercarriage), all travel control functions are reversed.

Always use caution when using the 10010MX’s travel controls as well as any other function.

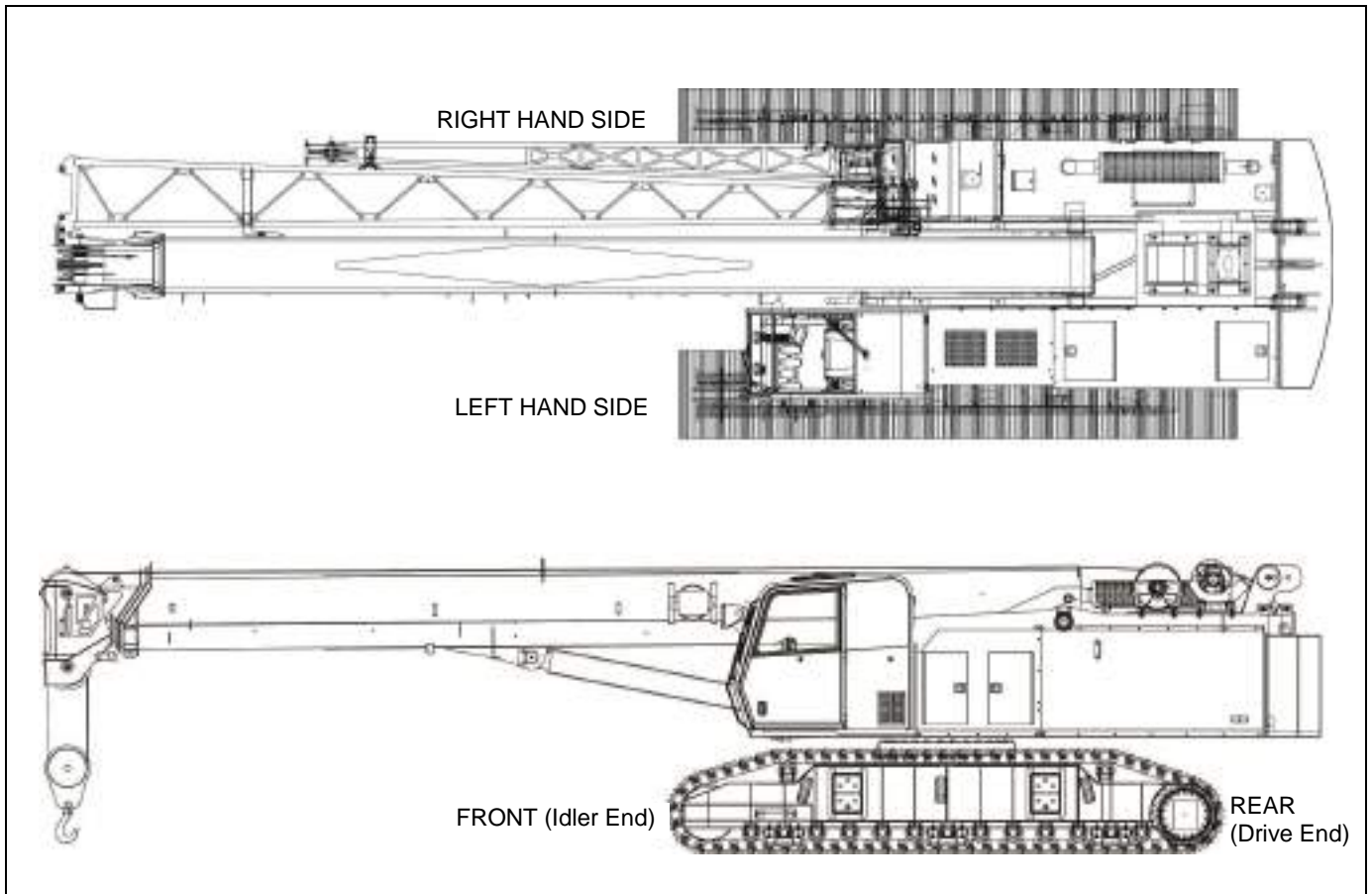

OVERVIEW

1.3 BOOM LOAD CHARTS

The following diagram represents a **load chart example**. The load charts are classified in various categories, depending on the crane's working configuration. For each job, the operator must select the table that is as close as possible to the actual working position. It contains all data required for crane work. All the data required for crane work must be entered in the RCI (Rated Capacity Indicator) before work is commenced.

The instructions provided in the "notes referring to the load chart" must also be observed.

1 = Work radius (distance between the center of the ring gear and the center of the bottom block or the load)

2 = Amount of counterweight, swing and/or working area and the specified track extension width

3 = Actual boom length

4 = Recommended parts of line reeving to achieve maximum rated capacity for each boom length with low speed winch operation

MANTIS Model 10010MX
as originally manufactured and equipped by Tadano Mantis Corporation.

360 DEGREE RATING - LOADS IN lb x 1000

MAIN BOOM with TRACKS FULLY EXTENDED									
20,000 lb COUNTERWEIGHT									
RADIUS (ft)	MAIN BOOM LENGTH (ft)								RADIUS (ft)
	37.5	45.4	53.3	61.2	73.8	86.4	99.0	111.5	
10	100.0	90.0	86.0	79.0					10
12	82.5	80.0	76.0	72.0					12
15	66.0	64.0	61.0	59.5	48.0	44.0			15
20	53.2	51.1	49.1	51.4	43.0	40.0	38.0		20
25	39.6	38.7	37.3	38.0	38.6	39.0	36.0	35.0	25
30	29.5	29.0	28.7	28.5	29.2	29.9	30.2	30.5	30
35		22.3	22.0	21.8	22.5	23.3	23.7	24.1	35
40			16.8	16.6	17.3	17.9	18.6	19.1	40
45			12.8	13.2	13.7	14.3	15.0	15.5	45
50				10.5	11.1	11.7	12.4	13.0	50
55				8.4	8.9	9.7	10.4	10.8	55
60					8.0	8.4	8.7	9.0	60
65					6.7	7.0	7.3	7.6	65
70						5.7	6.0	6.3	70
75						4.6	5.0	5.3	75
80						3.7	4.1	4.4	80
85							3.2	3.6	85
90							2.7	3.0	90
95							2.1	2.4	95
100								1.9	100
105								1.1	105
Parts of line	10	8	8	7	5	4	4	3	Parts of line

OVERVIEW

1.3.1 Capacity Limits and General Conditions

The Tadano Mantis 10010MX Crane as manufactured by Tadano Mantis Corporation meets the requirements of ASME B30.5 (2011) when specifically equipped. Structure and stability have been tested in accordance with SAE J1063 and SAE J765, respectively. Lifting capacities as determined by boom length, angle, or lifting radius apply only to machines as originally equipped by the manufacturer and in a properly maintained condition.

- Capacities given are maximum covered by the manufacturer's warranty and are based on a freely suspended load with no allowance for factors such as out-of level operation, supporting surface conditions, hazardous surroundings, experience of personnel, etc.
- Establish practical working loads based on prevailing operating conditions such as, but not limited to, those listed above.
- When making lifts where capacities may be within a zone limited by structural strength, determine that the weight of the load is known within $\pm 10\%$ before making the lift.



DO NOT lift a load without consulting the load chart. Deductions from rated capacities must be made for the weight of the hook block, overhaul ball, slings, spreader bar, or other suspended equipment.



Side pull on the boom is extremely dangerous and must be avoided. DO NOT exceed the manufacturer's specified maximum reeving.

- Load radius is defined as the horizontal distance from the axis of rotation to the center of the lifting device after load is applied.
- Boom angle is the included angle between the longitudinal axis of the boom base section and the horizontal axis, after lifting the load. The boom angle before lifting should be somewhat greater than desired to account for boom deflection.
- Boom angle/boom length relationships given in the load charts are an approximation of the resulting load radius. The radius should be accurately measured.
- Boom height dimensions are measured from ground to center of lower boom head sheave.
- You may attempt to telescope the boom with a load within the limits of rated capacities. However, boom angle, system hydraulic pressure, and/or boom lubrication may affect operation.
- The load moment indicator system used on the 10010MX is an operational aid that warns the crane operator of approaching overload conditions and also warns of over hoist conditions that could cause damage to the equipment and injury to personnel.
- The device is not and shall not be a substitute for good operator judgment, experience, and the use of accepted crane operating procedures.
- It is the responsibility of the operator to ensure safe operation of the crane and that he understands and observes all supplied warnings and instructions.
- Prior to operating the crane, carefully and thoroughly read and understand the information in this manual to ensure knowledge of the operation and limitations of the RCI/A2B system and crane.
- Proper functioning is dependent upon proper daily inspections and upon observation of the operating instructions set forth in the RCI/A2B manual.

OVERVIEW



Conditions Contributing to the Risk of Tipping the Crane

- a. Load and/or working radius specified in the load charts are not strictly adhered to.
- b. Weight of the load is not determined before lifting.
- c. Swinging of the load due to improper crane operation.
- d. Side load induced by pulling at an angle to the booms longitudinal axis.
- e. The ground is not capable of supporting the crane and the suspended load.
- f. The ground is uneven or sloped beyond acceptable parameters as described in the load charts.
- g. Insufficient distance between the crane and holes, ditches, or other working surface instabilities.

OVERVIEW

1.4 TECHNICAL DATA

1.4.1 Standard Crane and Equipment

The Tadano Mantis 10010MX was designed and built to provide a long service life when it is used and maintained in accordance with the instructions in this manual. Although replacement components may be available from various sources, it is highly recommended, in order to maintain the integrity of this crane, only genuine Tadano Mantis service parts be used for replacement. In addition, the structural steel components of this crane are constructed of high strength alloy steel, requiring proper welding techniques to prevent compromising the integrity of this crane, should a repair be necessary. Please consult your authorized Tadano Mantis dealer or Tadano Mantis Customer Support before repairing or replacing structural components on this crane.

Dimensions and Weights:

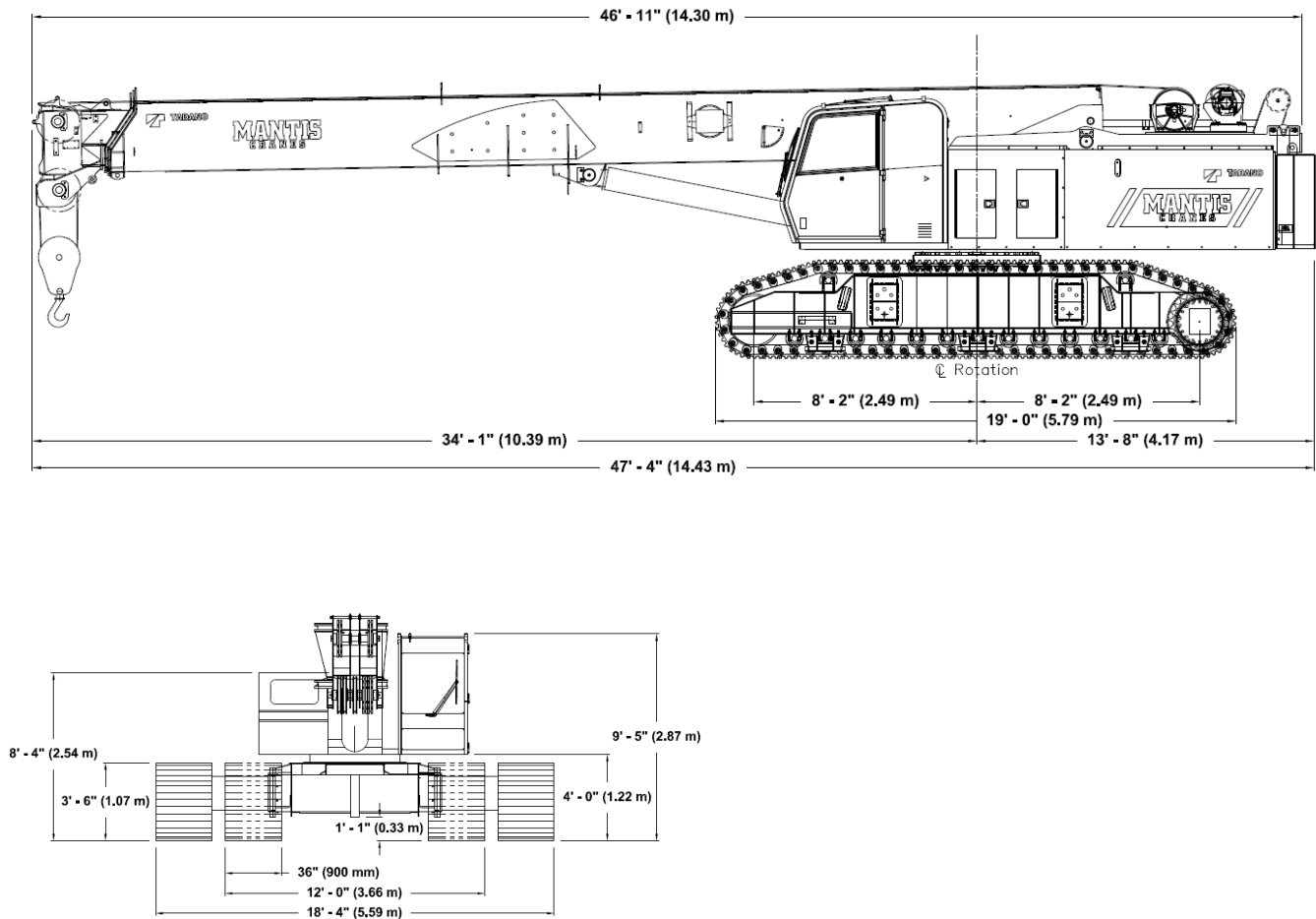

WIDTHS, WEIGHTS, AND GROUND PRESSURES*

Sole Width	Overall Width		Area	Ground Pressure	Working Weight
	Retracted	Extended			
24 in (609 mm)	11 ft 0 in (3.35 m)	17 ft 2 in (5.23 m)	3,360 in ² (6.04 m ²)	10.7 psi (0.75 kg/cm ²)	99,650 lb (45,220 kg)
30 in (762 mm)	11 ft 6 in (3.51 m)	17 ft 8 in (5.39 m)	41,700 in ² (7.95 m ²)	8.7 psi (0.61 kg/cm ²)	101,670 lb (46,120 kg)
36 in (900 mm)	12 ft 8 in (3.86 m)	18 ft 4 in (5.59 m)	44,040 in ² (8.06 m ²)	7.4 psi (0.52 kg/cm ²)	103,840 lb (47,070 kg)

* Crane equipped with 111 ft, 4 in boom, extension, jib, 59 ton level hook, 1/2 ton loadable ball

OVERVIEW

1.4.2 Boom

The boom consists of four full power sections, 37.6 ft (11.4 m) retracted and 111.6 ft (34 m) fully extended. Maximum tip height is 117 ft (35.7 m). The max tip height with the optional jib and extension is 166 ft (50.6 m).

Angle of boom adjustment	-1° to +78°
Time required for boom angle adjustment	approx. 44 s

1.4.3 Boom Telescoping & Elevating Systems

The elevating system features a cylinder and counterbalance lock valves, which provide boom elevations from -1° to 78°. The telescoping system features one double-acting hydraulic cylinder, wire rope pendants, sheaves and counterbalance lock valves.

Total length retracted	37.6 ft (11.4 m)
Total length extended	111.6 ft (34 m)
Max. pulley height	117 ft (35.7 m)
Time for extending the telescopes	Approx. 105 s

1.4.4 Boom Head

Seven 19 in (483 mm) diameter, cast nylon sheaves on heavy-duty roller bearings are mounted in the boom head (five load bearing and two lead in sheaves).

1.4.5 Rated Capacity Indicator

Standard RCI system includes audible and visual warnings and function shutdown. The system's LCD screen provides a continuous electronic display of working boom length, boom angle, working load radius, tip height, parts-of-line (operator set), machine track configuration (operator set), relative load moment, maximum permissible load and actual load. The standard work area definition audio and visual warnings aid the operator in avoiding job-site obstructions by presetting and defining the work area.

1.4.6 Anti-Two Block

Standard anti-two block system includes audible warning and function shutdown when imminent two-block conditions exist.

OVERVIEW

1.5 SUPERSTRUCTURE

1.5.1 Frame

The frame is an all-steel, welded structure, precision machined to accept attachment of the boom and swing devices.

1.5.2 Engine

Cummins 6 cylinder diesel engine, Type QSB6.7 certified to EU Stage IIIA, US EPA Tier 3 emissions. The engine speed can be varied progressively via a pedal or by the preset and increment/decrement buttons on the display.

Power	194 kW (260 BHP @ 2200 rpm)
Max. torque	987 N-m (728 lb-ft @ 1500 rpm)
Fuel	Diesel
Operation	Four-stroke direct injection
Piston displacement	6.7 L (409 in ³)

1.5.3 Operator's Cab

The fully-enclosed, air conditioned, all-steel modular cab includes a lockable swinging door, acoustical lining, anti-slip floor, and tinted safety glass. Sliding windows are located in the cab door and cab boom side. A vent window is positioned in the rear of the cab. Grab bars and steps are appropriately located for easy access to the cab.

Standard cab accessories include a two-speed windshield wiper, top glass wiper, defroster, heater, air conditioner, circulating fan, foot throttle, six-way adjustable fabric seat with headrest, seat belt, dome light, and a dry-chemical fire extinguisher.

In an emergency, if the main access door of the cab is blocked, the sliding glass window to the right of the operator's seat can be used as an emergency exit. A glass-breaking hammer is supplied and attached to a panel just below the window.

1.5.4 Instrumentation and Accessories

An integrated monitoring and control system provides engine instrumentation, hydraulic system monitoring, and 2 camera views. Engine instrumentation features a tachometer, voltmeter, temperature gauge, hour meter, and fuel gauge. Hydraulic system monitoring provides fluid level, fluid temperatures, pump pressures, pilot pressure, and load sense pressures. Winch rotation is indicated by thumper in respective joystick. Cameras' views are set up to provide a rear view from the crane as well as a view for monitoring winch operation. Warnings include low fuel level, low fluid level, fan solenoid fault, high hydraulic temperature, return filter clogging, pilot filter clogging, and air filter clogging.

In addition, indicators are provided for crane level and load moment.

A termination switch is located in the seat that is capable of immediately disabling all hydraulic functions as the operator rises from the seat. Additionally, a termination switch is located in the left hand armrest that can be activated by lifting the armrest.

1.5.5 Control

Four-way electronic joysticks mounted in the operator's seat armrests control swing, auxiliary hoist, main hoist, boom telescope, winch hi-speed/low-speed and boom hoist in standard mode. Two two-way electronic foot pedals

OVERVIEW

control travel. A single one-way hydraulic pedal controls the swing service brake. Joystick functions change according to the operating mode selected by the operator.

1.5.6 Counterweight

The 20,000 lb (9070 kg) single-piece counterweight can be removed and installed via a pendant attached to the boom.

1.5.7 Hoist Winches

Planetary geared, two-speed winches are powered by open loop bent axis variable displacement motors, with a multi-disc internal brake. Winch Drum rotation indicators provide audible signals to the operator when the drum is in motion.

	Main Winch	Aux Winch
Drum diameter	10.63 in (270 mm)	10.63 in (270 mm)
Rope diameter	.63 in (16.0 mm)	.63 in (16.0 mm)
Approx. rope length	550 ft (152 m)	350 ft (107 m)
Hoist line pull, max Low speed High speed	15,000 lbs (66.7 kN) 7,500 lbs (33.4 kN)	15,000 lbs (66.7 kN) 7,500 lbs (33.4 kN)
Max. line speed Low speed High speed	205 ft/min (62 m/min) 415 ft/min (126 m/min)	205 ft/min (62 m/min) 415 ft/min (126 m/min)

NOTE

◆Maximum allowable line pull may be limited by rope strength at allowable safety factors. Allowable line pull by parts of line with standard wire rope is listed in the table below.

WIRE ROPE LINE PULL CAPACITIES*				
10010MX				
Parts of Line	Main Winch		Aux Winch	
	lb	kN	lb	kN
1	11771	52.4	11771	52.4
2	23542	104.7	23542	104.7
3	35313	157.1		
4	47084	209.4		
5	58855	261.8		
6	70626	314.2		
7	82397	366.5		
8	94168	418.9		
9	105939	471.2		
10	117710	523.6		

*Based on 5/8" (16mm) diameter 6x36, IWRC, EIPS rope.

1.5.8 Safety Equipment

Critical hydraulic circuits are protected from movement in the event of loss of pressure by counterbalance valves.

OVERVIEW

1.5.9 Electrical Equipment

12 Vdc systems with two batteries (12V, 900 CCA each), three remote-operated spot lights, and strobes mounted on the back corners for swing warning.

1.5.10 Swing

The superstructure rotates 360° around a shear ball slew bearing with an external gear that matches with the swing drive pinion and bolts to the superstructure and the carbody. The hydraulic swing drive powers the system and consists of a gear motor driving into a planetary reducer with a shaft mounted pinions providing infinitely variable speeds of up to 2.2 rpm.

Swing braking is achieved through a “failsafe,” hydraulically released, spring applied, multi-disc wet brake, which includes a foot applied service brake. The brake can be electrically actuated through a cab mounted switch into a “locked-on” (parking) mode. A two-position house lock system is included. The operator may turn free swing mode on and off through the display. Regular lubrication of the bearing is achieved through a cab mounted grease applicator.

1.5.11 Fuel System

An 80 US gal (300 L) tank is bolted to the superstructure. The fuel filtration system consists of an inline fuel/water separator as well as an engine mounted fuel filter.

1.5.12 Hydraulic System

The load sensing, open-loop hydraulic system is served by two variable volume pumps mounted in tandem. The pumps provide a maximum output of 168 gpm (636 lpm) @ 2,200 rpm and maximum operating pressure of 4,800 psi (330 bar). An extra circuit is included for ready adaptation to hydraulic accessories.

The system includes two electro-hydraulically pressure and flow compensated valve banks. The 300 gal (1136 L) capacity hydraulic oil reservoir has a spin-on filter-breather cap, clean-out access and a sump type drain. An air to oil remote mounted cooler provides oil cooling with thermostatically-controlled, hydraulically driven fans. Hydraulic oil filtering is achieved with three 5-micron full flow cartridge type filters designed to return in-tank with bypass protection and an electronic bypass indicator.

System pressure test ports with quick disconnect fittings are provided for diagnostics.

1.6 UNDERCARRIAGE

1.6.1 Carbody

The welded steel, box type carbody is fabricated with square axles to accept the crawler side frames. The top surface is precision machined to receive the slew bearing.

1.6.2 Side Frames

Two welded steel removable side frames are paired with a track group consisting of two top and thirteen bottom oil-filled & sealed rollers. Each frame includes an oil-filled, self-lubricating idler and spring type, track tensioning device. Standard track shoes are 36 in (900 mm) wide three bar semi-grousers. The side frames extend and retract hydraulically and are electrically controlled from the cab.

1.6.3 Travel

Each side frame contains a pilot controlled, two-speed track drive. The drives are hydraulic piston motors, which propel the crane at a low speed of 0.9 mph (1.5 km/hr) and at a high speed of 1.5 mph (2.4 km/hr). The internal brake system is spring applied and automatically released upon actuation of the travel system. The hydraulic travel system provides skid steering and track counter-rotation and achieves an unladed grade-ability of 68%.

OVERVIEW

1.7 OPTIONAL EQUIPMENT

1.7.1 Boom Attachments

- **Boom Extension:** 30 ft (9.1 m) lattice type swingaway that stores alongside of the boom base section and can be used with or without the optional 20 ft (6.1 m) jib. Head contains two 19 in (483 mm) diameter high strength cast nylon sheaves mounted on heavy duty roller bearings, reeving up to two parts of wire rope. With the extension deployed the maximum tip height is 145 ft (44.2 m).
- **Boom Jib:** 20 ft (6.1 m) lattice type swingaway, attaches to and stores alongside the extension and can only be used with the extension deployed. Offsets are at 15° and 30°. With jib and extension deployed the maximum tip height is 166 ft (50.6 m).
- **Auxiliary Boom Head:** quick reeve, single 19 in (483 mm) diameter high strength, cast nylon sheave mounted on a heavy duty roller bearing boom tip adapter.
- **Wire Rope:** rotation resistant (non-spin) 0.63 in (16 mm) wire rope is available.
- **Overhaul Ball:** 12 US ton (11 metric ton) ball includes a bottom swivel hook and safety latch.
- **Hook Block:** 50 US ton (45 metric ton) hook block consists of five 16 in (406 mm) diameter steel sheaves mounted on heavy duty roller bearings with a swivel hook and safety latch.

1.7.2 Hydraulic

- **Auger Ready Package:** includes hoses, fasteners and stowage bracket assembly mounted to the base section of the boom with a flow capability of 34 gpm (130 lpm).
- **Complete Auger Package:** adds a two-speed auger motor/gear box and two 60 in (1.52 m) Kelly bars to the Auger Ready Package.
- **Tool Circuit:** provides 5 gpm (19 lpm) and 10 gpm (38 lpm) at 2500 psi (176 kg/cm²) through a 50 ft (15.24 m) twin hose reel with quick disconnect fittings to operate open center tools.
- **Pole Claw Kit:** includes boom tool circuit, boom-mounted dual twin hose reel, pole claw, wiring harness, valves, mounting brackets, and fasteners.

SAFETY INSTRUCTIONS

SECTION 2. SAFETY INSTRUCTIONS

Most accidents that occur during crane operation and maintenance are caused by failure to observe basic safety rules and precautions. Before operating your machine or performing maintenance, read and become familiar with all the safety precautions and recommendations given in this section. Remember that failure to observe even a single precaution could involve you and the people around the machine in a serious accident.

Foreseeing potential dangers is vital for preventing accidents. All personnel working with the machine, including the supervisor, crane operator, and rigger, should be sensitive to potentially dangerous situations and take the necessary measures to prevent accidents.

Safety precautions and recommendations are outlined in this section and are also included in the operation and maintenance instructions given in subsequent sections. Warning labels are also provided on the machine. The cautionary instructions in this manual and on the labels are identified as "DANGER," "WARNING," or "CAUTION."



DANGER indicates an imminently hazardous situation which, if not avoided, will result in death or serious injury.

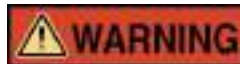

WARNING indicates a potentially hazardous situation which, if not avoided, could result in death or serious injury.



CAUTION indicates an important operational or maintenance procedure or condition, which, if not strictly observed, can result in damage to machine components or deteriorated machine performance.

It is virtually impossible to anticipate every situation that might present a hazard. The safety precautions given in this manual and on the machine labels are not exhaustive. It is important, therefore, to strictly follow the instructions in this manual and be sensitive to potential dangers in order to prevent bodily injury and damage to the machine.

NOTE

◆Remember that your most important duty is to ensure the safety of you, your coworkers and any other people in the area.



Use of an improper or unauthorized method during operation or maintenance of this machine can be dangerous and could lead to serious injury or death. Read this manual thoroughly and be familiar with the proper operating and maintenance procedures before using the machine. Do not operate the machine or perform maintenance on it until you understand the instructions in this manual.

SAFETY INSTRUCTIONS

2.1 BASIC SAFETY RULES

The operator should:

- Have sufficient experience in working with cranes and be sufficiently trained and qualified as a crane operator
- Be in good health, emotionally stable and not subject to physical disability
- Not be using any medicine or drug that impairs physical, visual or mental response
- Ensure that all personnel who are going to enter the working area wear a helmet, safety shoes, or gloves, in accordance with local regulations or in-house rules
- Be in good physical condition to be prepared for the job
- Master the techniques for safe control of the machine and be completely familiar with the operation and maintenance instructions given in this manual
- Wear clothing suitable for the job (avoid loose-fitting garments or loose-hanging accessories)
- Wear shoes with non-slippery soles
- Clean shoes before entering the crane operator's cab (this helps reduce the danger of an accident that could result from losing your footing on a step or accidentally releasing a pedal)
- Use both hands when getting in or out of the cab (safely climb onto or descend from the machine using the handrails and steps; avoid jumping off the machine except in an emergency)
- Keep the cab, the deck, and any other area free of mud, oil, grease or water (also keep the control console clear of any objects that may obstruct free operation of the controls)
- Do not climb on the boom, jib or outriggers; it is very easy to fall and be injured (when working at an elevated position, use a platform to prevent an accident)
- When on the carrier or swing table for inspection or other purposes, beware of the overhead clearance and watch footing; take care not to slip and walk on the anti-slip strips if provided; worn anti-slip strips should be replaced
- Never get on or off a moving machine

2.2 INSTRUCTIONS FOR CRANE OPERATION

- The crane is ready to operate at ambient temperatures in the range from -4°F (-20°C) to 115°F (46°C).
- Loads may only be lifted after people have left the danger zone.
- Traveling with loads is allowed as indicated in the appropriate load chart.
- The maximum admissible wind velocity and load wind area according to the load chart must not be exceeded. Contact the manufacturer for high wind speed operational limits.
- Check that the ground is level within the limits of the appropriate load chart to be utilized during operation.
- Construction sites must be sufficiently illuminated for work at night. The crane's work lights alone might not be sufficient for this purpose. In this case, the construction site must be illuminated sufficiently by additional light sources, independent of the crane lighting equipment.
- As long as the engine is running and/or a load is suspended freely, the operator must not leave the cab.
- Before the operator leaves the cab, he must place the load on the ground, stop the engine, and remove the ignition key.

SAFETY INSTRUCTIONS

2.3 CRANE APPLICATION IN ACCORDANCE WITH THE INTENDED USE

Crane application in accordance with the intended use is operation as an assembly crane, and consequently, lifting and transporting of loads. The machine has been designed and built only for operation in areas where there is no risk of explosion.

2.4 LIFTING CAPACITIES OF CRANE

- Check the load rating chart before every operation to be sure that the lift is safe. Remember that the load lifting capacity of the machine varies depending on boom length and working radius. Never exceed the chart-rated load (load rating chart located in the cab). If a load exceeding the rated capacity is lifted, the machine becomes overloaded. This error could destroy the machine or make it overturn.
- Avoid operating the machine under any conditions for which there are no capacities given on the load rating chart. For example, under certain conditions, the machine will overturn even without a load on the hook, possibly causing a serious accident.
- The lifting capacities are based on machine strength and stability. When strength is the primary factor for rating capacity, overloading will cause the machine to break before it overturns. Do not regard the likelihood of overturning as the only indicator of an overload.
- Check the weight of the load before lifting it. The specified total rated load should never be exceeded. Remember that the total rated load also includes the weight of the hook block rigging and load handling devices (see right figure).

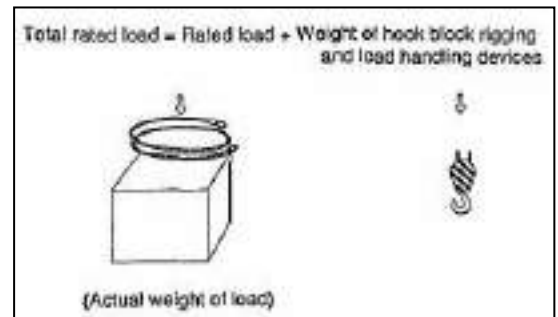

- The load rating charts are based on the following conditions:
 - The machine is placed on firm ground that is level with the limits stated on the appropriate load chart.
 - Wind speeds are within the limits of the appropriate load chart.
 - There are no side loads and the load is not swinging.
 - The machine is not damaged or malfunctioning, and is in proper operating condition.
- When operating the machine under the above conditions is not possible, the weight of the load must be reduced accordingly. Adjustment of load weight requires good judgment and experience. Typical conditions requiring reduction of load are:
 - The machine is on ground of uncertain support.
 - There is steady wind or strong gusts.
 - There are hazardous objects near the machine.
 - Visibility is poor.
 - The load is fragile.

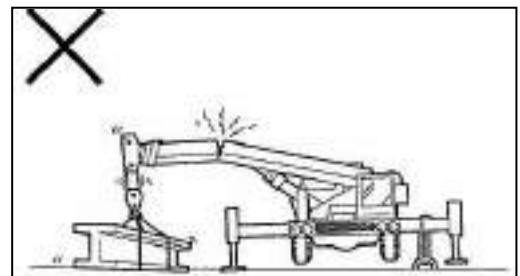

- Do not try to hold down the extend beams or track frames or other machine sections with anchoring ropes to prevent the machine from overturning, which can increase the possibility of an accident or damage to the machine due to false conditions (see right figure).
- Do not increase the counterweights on the machine above the specified limit. Also, avoid placing anything on the machine that may act as a counterweight. Excessive counterweight can affect the machine's

SAFETY INSTRUCTIONS

rearward stability. It will also make the operator less sensitive to overloading, increasing the chance of an accident.

- On some cranes, counterweights of different weights can be selectively mounted. When working with such a crane, it is imperative to know the correct amount of counterweight installed on the machine, as the weight directly affects the lifting capacity. Check the counterweights, then check the applicable total rated load table to find the rated load capacity. Be sure to use the correct table. Using the wrong table is extremely dangerous.
- The number of wire rope parts of line is determined by the boom length and the weight to be lifted. Use the standard number of parts of line listed under “parts of line” on the load chart.
- Do not exceed the allowable load per line as listed in the load rating charts.

2.5 SAFETY DEVICES

The RCI functions properly only when used exactly as instructed in the manual supplied with the machine. Failure to follow the instructions given there could cause the machine to overturn or be damaged, leading to a serious accident.

Make sure that the safety devices (RCI, anti-two block hoist limit switch, winch third wrap shutdown, etc.), and the alarm devices are always in good working order. Should any device malfunction, do not use the machine until it is required. Avoid any act that can impair normal operation of the vehicle.

A safety device is not a substitute of human skill and judgment. Safety devices are provided only as an aid to the operator; they themselves cannot control the machine. For example, the RCI does not provide a warning when the crane is on soft loose, ground or when the number of parts of line is insufficient. It cannot predict the effect of wind, improperly adjusted devices, side loads on the boom, or any other potentially hazardous condition on the crane. Many safety devices can assist the operator in achieving safe results, but the operator should not depend solely on them to prevent accidents. Operating safety requires all the qualities of a good operator, including skill, experience, good judgment, and safety awareness.

2.6 BEFORE CRANE OPERATION

- Check the ground conditions on the site of crane operation with regard to stability (load-bearing capacity); if necessary, reinforce the ground with appropriate crane mats.
- The lifting capacities indicated in the load charts are only valid for the ground conditions and crane configuration indicated on the appropriate load chart.
- Extend the extend beams completely. If they are not completely extended, the lifting capacity of the crane is reduced.
- Before starting to work with the crane, check the vehicle’s hydraulic system and all controls and gauges for proper working order.
- Use the shortest possible boom length and work radius on all accounts. The work radius is the distance between the center of the rotation and the center of the hook block.
- Know the size and the weight of the load to be lifted.
- The hook block, the rigging, the spreader beam, etc. are parts of the load and must be deducted from the lifting capacities in question.
- Check the safety equipment installed in the machine for precision and proper working order. If the operating staff is not 100% sure about its function or reliability, crane work must not be started.
- The legal regulations in force in the country where the machine is to be registered must be observed.

SAFETY INSTRUCTIONS

- Do not operate a malfunctioning or improperly serviced crane. Using such a crane could endanger your own and other's lives. Be sure that there is no "do not operate" sign posted in the crane operator's cab (see right figure). If one is present, do not move any of the controls until the maintenance personnel have completed their job and removed the sign. Replace any broken or missing protective guards, such as covers and warning labels, immediately.
- Before starting operation (and before taking over a shift), perform the pre-operational inspection. Make sure that the machine is checked daily and serviced properly. Do not operate a damaged or improperly serviced machine. During the pre-operational inspection, pay special attention to the winch brake, swing brake, wire rope and load handling devices.
- Every wire rope wears with use, eventually losing its necessary strength. Inspect wire ropes before the start of every operation and replace them if they are worn or otherwise damaged beyond the acceptable limit. Also check the boom head and hook block sheaves for excessive wear. Damaged sheaves can hasten deterioration of the wire ropes (see right figure). Use only the Tadano recommended wire ropes.
- When working inside a building, check side and overhead clearance to avoid hitting anything. Also, check the floor load limit to ensure that the floor will not collapse under the weight of the crane.
- The work area should be fenced and posted to prevent unauthorized people from entering (see right figure).
- All working personnel must know the existing conditions and dangers of the work site. Pay special attention to ground conditions and buildings in the immediate vicinity of the machine.
- Perform proof tests before actually lifting load. Bear in mind the conditions of the work area. Plan for the job before putting the load on the hook block.

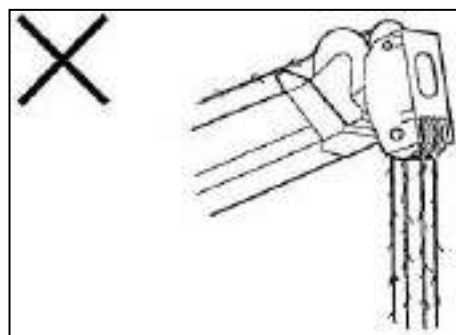
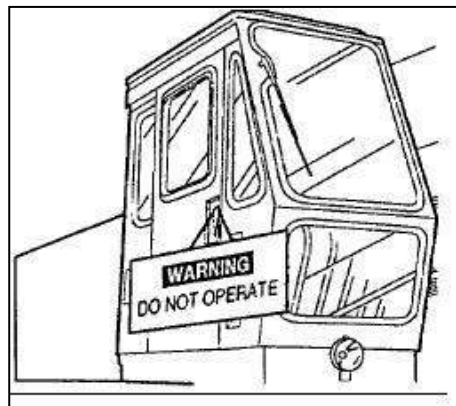

2.7 PLACEMENT OF CRANE

Always place the machine on a firm surface. The machine should not be on soft ground, which has the risk of sinking, sliding or collapsing, nor on the edge of a pit or bank.

Use a spirit level to be sure that the machine is set on ground with the level requirements of the appropriate load chart. If the machine is listing slightly, the radius will change as the crane swings. This may cause the machine to become overloaded even if the lifted load is within the limit specified in the total rated load table. Overloading could cause the machine to overturn and/or the boom to break.

2.8 COUNTERWEIGHT

The size of the counterweight required is determined by the working radius required for the crane work in question and by the weight of the load to be lifted. The counterweight has to be mounted onto the crane in accordance with the counterweight data specified in the load chart, which is required for the crane work in question.

SAFETY INSTRUCTIONS



None of the counterweight belonging to the machine may be replaced by counterweight of other machines.



If the crane is not equipped with the counterweight specified in the load chart, there is a risk of overturning.

2.9 RIGGING AND SIGNALING

- Wire ropes and chains used for rigging the load must be of proper size and damage free. Damaged load handling devices can fail under load, causing the load to drop. Wire ropes and chains must not be crossed or twisted around each other.
- Never use the hoist line as a sling (see right figure).
- Be sure that the load is rigged securely. The rigging must not slip off the load or move out of position.
- The hook block is provided with a latch. Make sure that it operates properly (see right figure). If the latch is damaged or malfunctioning, the load handling devices may come off the hook, allowing the load to fall.
- Lift one load only. Do not lift two or more separately rigged loads simultaneously even if their total weight is within the specified load limit; it is impossible to give complete attention to all loads simultaneously (see right figure).
- A qualified signal person should always be available and must be posted when:
 - Working near power lines
 - The load is hidden behind objects
 - Moving the machine to a place or in a direction where the operator's view is obscured
- Always use standardized OSHA hand signals that have been agreed upon previously and are understandable to both operator and the signal person.
- When working in a location with poor visibility, the signal person should stand at a place where he or she can see all the area the operator cannot, and where the operator can see the signal person. The operator must follow the signal person's instructions.
- If the signal person disappears from view, stop operation and wait until you can again see the signals.
- Only qualified persons should be assigned as signal persons, and only the signal person's instructions should be followed. However, a stop or emergency shutdown signal must be obeyed whoever gives it.

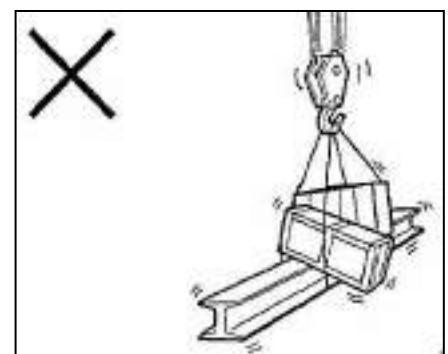
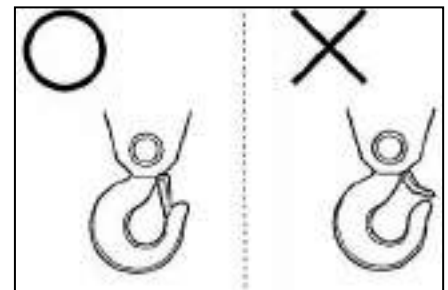
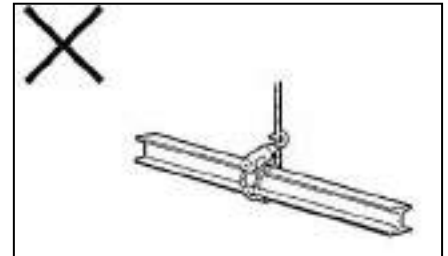

SAFETY INSTRUCTIONS

2.9.1 Recommended Hand Signals

During all intended crane movements (with or without load), the crane operator must always have the load or the load lifting device in his field of vision. Loads fixed by hand may only be moved by the crane operator after he has received a corresponding signal from the person fixing the load or from another responsible person who has been determined in advance.

If the crane operator's field of vision is impaired by obstacles, he may only move the crane or the load with the help of an assistant determined in advance, who gives him appropriate instructions.

The instructions can be given radio equipment or hand signals. However, clear communication free from misunderstandings must always be ensured between the assistant giving the instructions and the crane operator.





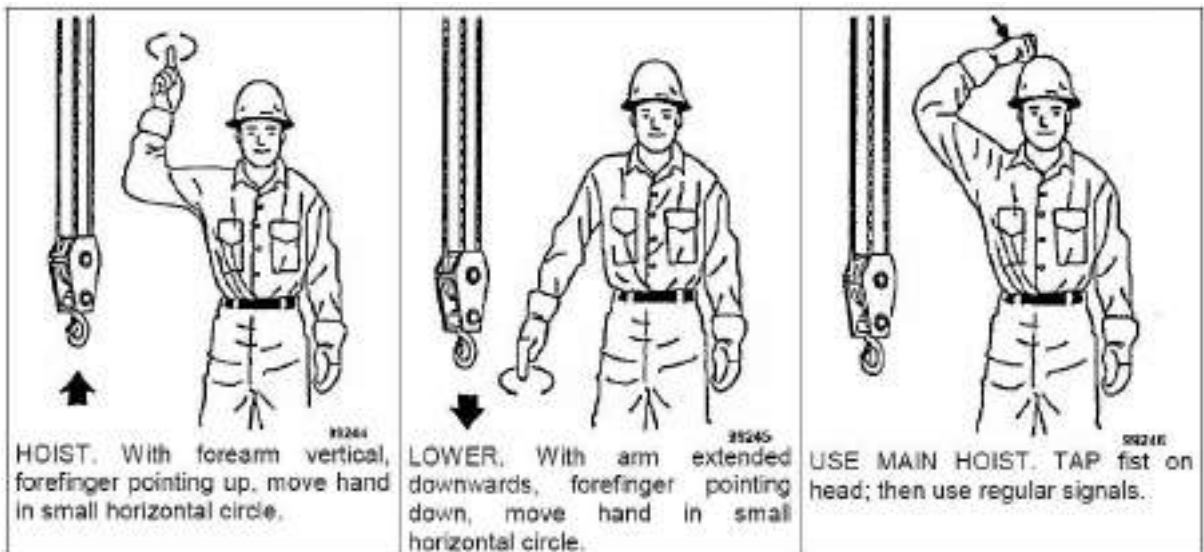

- ❖ **Hand signals and special verbal expressions must be agreed between the crane operator and his assistant and observed precisely.**
- ❖ **Any mistakes regarding the interpretation of the hand signals or verbal expressions may result in accidents.**
- ❖ **The persons giving the hand signals must always be placed so that he can see the crane operator, and keep at a safe distance from the hook or the load.**

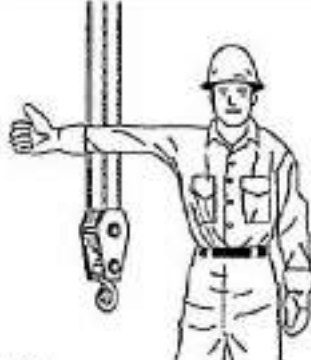
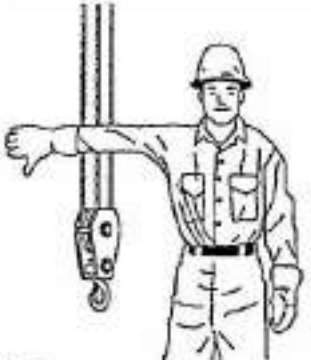
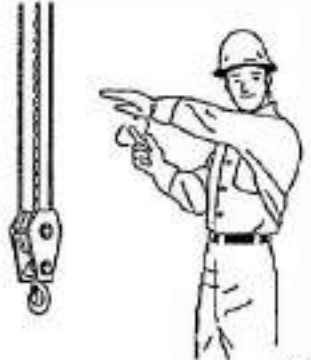
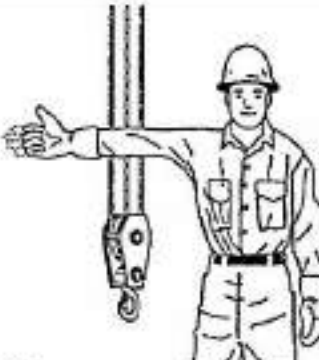
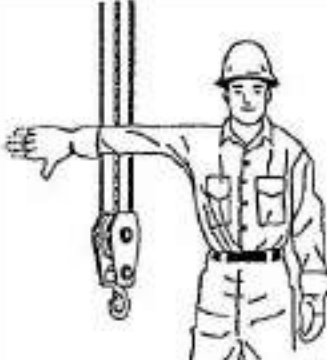

Hand signals shown are an excerpt from ASME B30.5-2011.

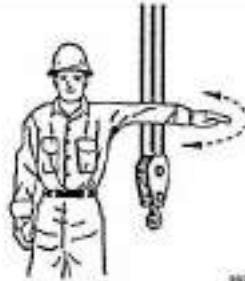



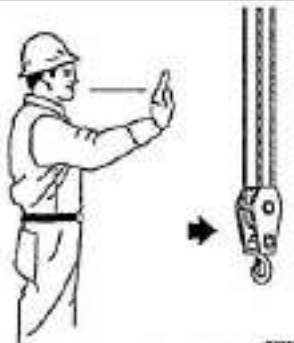

SAFETY INSTRUCTIONS

 <p>99247 USE WHIPLINE (Auxiliary Hoist). Tap elbow with one hand; then use regular signals.</p>	 <p>99248 RAISE BOOM. Arm extended, fingers closed, thumb pointing upward.</p>	 <p>99249 LOWER BOOM. Arm extended, fingers closed, thumb pointing downward.</p>
 <p>99250 MOVE SLOWLY. Use one hand to give any motion signal and place other hand motionless in front of hand giving the motion signal. (Hoist slowly shown as example).</p>	 <p>99251 RAISE THE BOOM AND LOWER THE LOAD. With arm extended, thumb pointing up, flex fingers in and out as long as load movement is desired.</p>	 <p>99252 LOWER THE BOOM AND RAISE THE LOAD. With arm extended, thumb pointing down, flex fingers in and out as long as load movement is desired.</p>
 <p>99253 SWING. Arm extended, point with finger in direction of boom.</p>	 <p>99254 STOP. Arm extended, palm down, move arm back and forth horizontally.</p>	 <p>99255 EMERGENCY STOP. Both arms extended, palms down, move arms back and forth horizontally.</p>

SAFETY INSTRUCTIONS

 <p>99290 TRAVEL. Arm extended forward, hand open and slightly raised, make pushing motion in direction of travel.</p>	 <p>99257 DOG EVERYTHING. Clasp hands in front of body.</p>	 <p>99258 TRAVEL (Both Tracks). Use both fists in front of body, making a circular motion about each other, indicating direction of travel, forward or backward. (For land cranes only).</p>
--	---	--

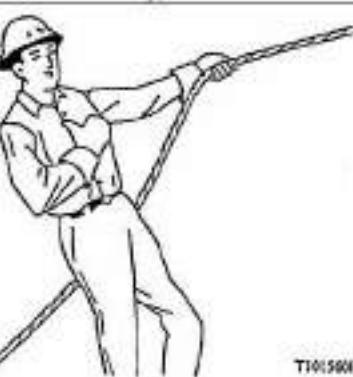
 <p>99259 TRAVEL (One Track). Lock the track on side indicated by raised fist. Travel opposite track in direction indicated by circular motion of other fist, rotated vertically in front of body. (For land cranes only).</p>	 <p>99260 EXTEND BOOM (Telescoping booms). Both fists in front of body with thumbs pointing outward.</p>	 <p>99261 RETRACT BOOM (telescoping booms). Both fists in front of body with thumbs pointing toward each other.</p>
---	---	--

 <p>T101500 EXTEND BOOM (Telescoping Boom). One Hand Signal. One fist in front of chest with thumb tapping chest.</p>	 <p>T101501 RETRACT BOOM (Telescoping Boom). One Hand Signal. One fist in front of chest, thumb pointing outward and heel of fist tapping chest.</p>
---	---

SAFETY INSTRUCTIONS

2.10 LIFTING OPERATION

- Do not lift two loads on both the boom and jib at the same time (see right figure). Loads fixed to the jib cause stress in the boom and temporarily reduce its capacity. Do not attempt such lifts even if the total load weight is within the machine's rated capacity. However, operation using two winches is possible (e.g. to position a load precisely or to turn it).
- Do not allow anyone to approach the crane or enter the swing circle of the crane structure during operation.
- The swinging structure or lifted load may hit objects or persons or create pinch points between fixed obstacles. Before starting operation, make sure that nobody is in the swing range.
- Lifting a load on the boom with the jib mounted is dangerous and should be avoided (see right figure). If conditions absolutely require it, perform the operation with the utmost care and attention.
- When the jib is mounted, using both the main and auxiliary winches simultaneously to lift a single load is dangerous and should be avoided (see right figure). If conditions absolutely require such an operation, perform the operation with the utmost care and attention.
- The crane is designed to lift a load that is completely free of any restraining forces. Do not try to lift pillars, stakes or other objects that are driven deep into the ground, or to pull loads out of mud or sand. Performing such jobs can impose unexpected stress on the crane, and cause it to be damaged or overturn.
- Do not let anyone ride on the hook block or load handling devices (see right figure). Use the crane to lift objects only.
- Never allow anyone to ride on the upper structure, crane carrier, engine compartment covering, or other crane parts during travel or for crane operations.
- Never use the boom or jib to push or pull objects. This practice can damage the boom and could lead to an accident (see right figure).

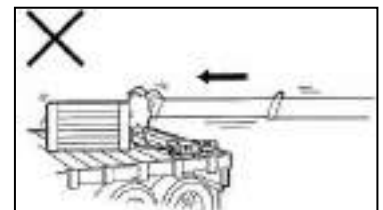
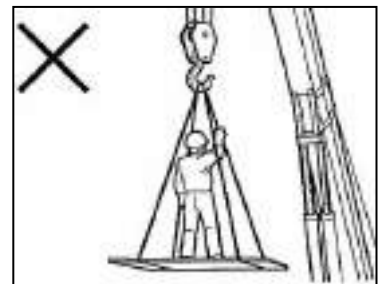
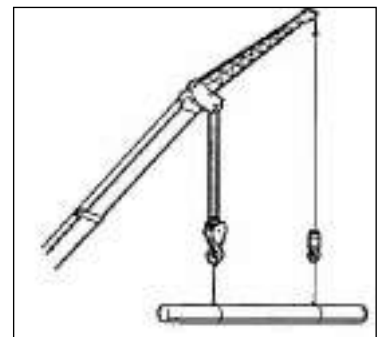
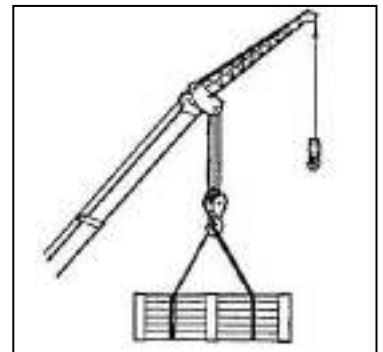
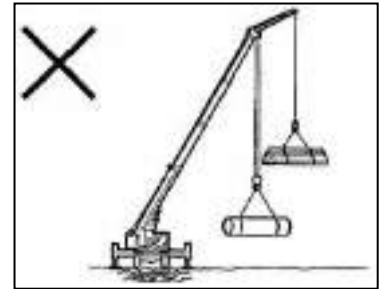

SAFETY INSTRUCTIONS

- Do not move a load, even slightly, by pulling sideways on the boom or jib. Always lift the load straight up. Pulling sideways can not only buckle or break the boom or jib, but it also damages the swing mechanism of the crane. It is especially dangerous to pull sideways on a boom raised to a large boom angle; the boom may break and overturn the machine (see right figure).

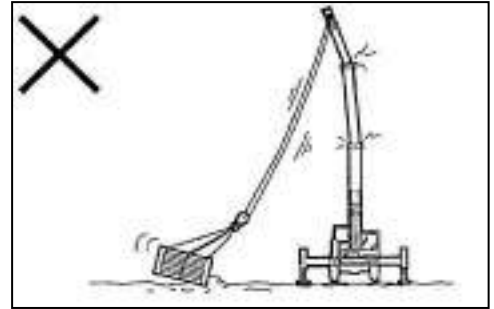

- Operate the crane from the cab only. Controlling the machine from the outside, through the cab window, is strictly forbidden and very dangerous (see right figure).

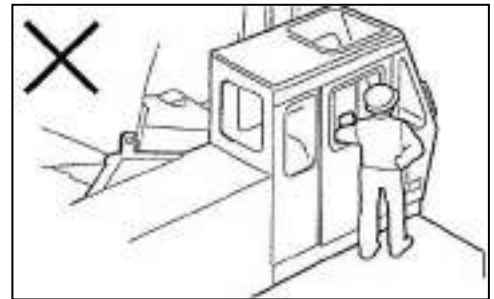

- Keep your attention on the lifted load at all times. Watch the signal person or the load when moving the load. If you are diverted or need to look elsewhere, stop operation.
- Do not move the control levers abruptly. Lift carefully so as to maintain a constant tension on the wire rope. Swing slowly, brake smoothly, and set loads on the ground gently. Moving the levers abruptly may cause the load to swing, placing a lateral load on the boom. This act could destroy the machine and possibly cause injury or death.
- Do not allow the load to hit the boom or jib. Avoid letting the boom or jib rest on or hit against a building or any other objects. Resulting dents or other damage will weaken the boom or jib, and if severe, may cause the boom or jib to collapse. Should the boom or jib hit against something, immediately halt operation and inspect. Do not continue operating the machine with a dented or otherwise damaged boom or jib. A damaged boom or jib must be repaired or replaced. Contact your nearest Tadano distributor or dealer for assistance.
- Measure the working radius before making a lift. Make allowance for increased radius due to boom deflection under load. When lifting, be careful not to let the load move outside the radius specified in the total rated load table.
- Use special care when handling a near-capacity load within the stability section of the total rated load table (where capacities are determined by the crane stability). If the load swings outward, the working radius increases. This effect considerably reduces machine stability and could result in overturning.
- Do not operate the machine in the dark or when visibility is poor due to fog, etc. Stop operation and stow the crane under such conditions (see right figure).

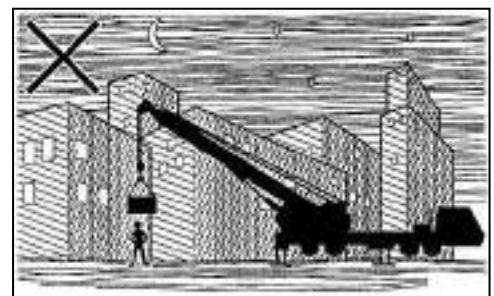

- Be careful not to let the load catch on an obstruction when it is being lifted or swung. Also, watch wire ropes and other crane parts to prevent them from getting caught on obstacles (see right figure).
- If a wire rope is slackened during reeving or other operation, make sure that the rope is properly seated in the sheaves and

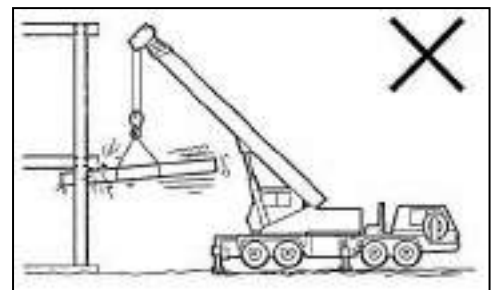

SAFETY INSTRUCTIONS

on the winch drum. If necessary, use a proper hand tool to seat the rope, being careful not to damage it. Do not try to seat the ropes directly with your hands; you may be injured.

- Be sure that the working area has been cleared of people and obstructions. Unauthorized people must not be allowed to approach the area. Rope off the job site and post a "keep out" sign.
- Pay attention to the machine and everything around it. If there is unusual wind or gusts, boom deflection, rope sway or anything abnormal, stop operation immediately to prevent accidents.
- Use the horn to signal the start of operation or warn a person approaching the machine.
- If the boom is elevated to raise a load clear of the ground, the machine will not be automatically stopped even in the case of an overload. An overloaded machine could overturn or be damaged. Use only the hoisting-up operation to raise a load clear of the ground.
- When a load is lifted, the boom deflects and may cause the working radius to increase beyond the allowable limit, creating an overload. Stop lifting when the load just clears the ground and check load conditions, as well as for any sign of overloading, before continuing.

- Be sure that the load is rigged so that it is suspended above a point just above its center of gravity. Improper rigging will cause the load to swing back and forth or sideways, which can be dangerous (see right figure).
- The winch brake must be able to hold the lifted load. Test the brake by raising the load just clear of the ground and holding it with the brake.

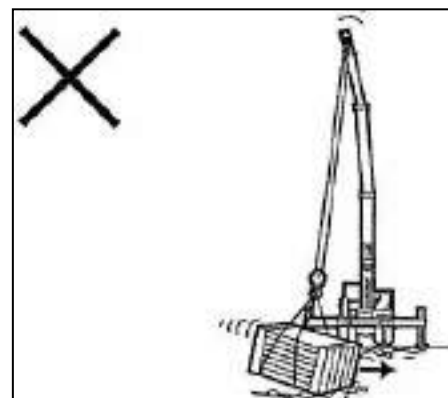

- If the load is heavy, it tends to move away from the machine just as the load clears the ground. This motion is caused by boom deflection. An outward swing of the load is not only dangerous to the people around the machine, but also increases the working radius and can overload the machine. If the load starts swinging when it is lifted, secure load control by setting it back on the ground and lifting it again.
- When the load is set on the ground, boom deflection decreases, causing the hook block to be pulled inward. Remember this when unhooking the load.
- When lifting a load submerged in water, it is important not to lift the load out all at once when it appears above the water's surface. The load may be impregnated with water and heavier than you expect. Allow to load to drain while raising it slowly. Draining may take a long time. A load lifted out of water, even when fully drained, weighs more than it did when submerged because of buoyancy effects.
- Use a number of parts of line appropriate to the length of the boom. If the number of parts is greater than specified for the boom length, the hoist line will be too short when the boom angle is increased. Also, when lowering a very light load, or the bare hook block without a load, the rope will unwind off the winch drum at a faster rate. The rope may then become improperly wound on the drum.

- At least three wraps of the rope must always be left on the winch drum (see right figure). Even with a standard number of parts of line, the wire rope may be too short if the load is lowered below ground level. Lowering of a load should be stopped whenever only four wraps of rope remain on the drum. If the entire amount of rope is let off the winch drum, the frictional anchoring force will be insufficient, permitting the rope to break or be damaged, possibly causing an accident. When the number of parts is reduced to below the standard to compensate for insufficient rope length, do not exceed the maximum lifting capacity for each part of line.

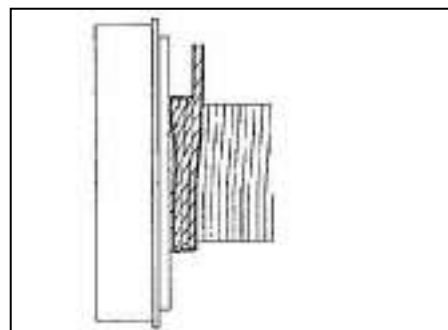

SAFETY INSTRUCTIONS

- Keep the boom length and lifting height as short as the job conditions allow. A load hung on a long wire rope may make the machine unstable when the suspended load swings, which could cause the boom to break (see right figure).
- A boom telescoped incorrectly may collapse. Be aware of an incorrect telescoping sequence when operating the machine. The total rated load table is based on correctly extending and retracting boom.
- Remember that the load lowers when the boom is retracted and rises when the boom is extended. Hoisting is required to maintain the load at a constant height during telescoping. If the boom is extended without letting the rope out, an "over-wind" or two-block condition could result. As long as the over-wind cutout device (anti two-block device) is functional, the crane will automatically stop when the hook block moves close to the boom head. But if the device is malfunctioning or is accidentally deactivated, the hook block may hit against the boom head, damaging the machine, or causing the wire rope to break and the load to drop.

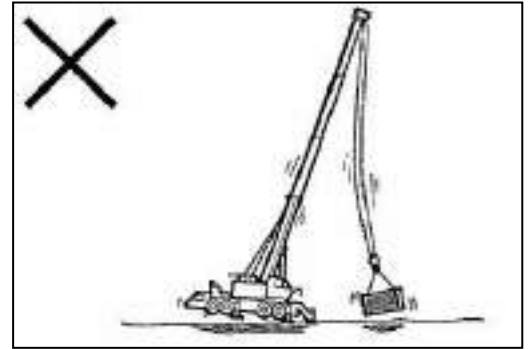

- Over-winding must also be prevented when hoisting up a load. Always be sure there is sufficient distance between the hook block and boom head (see right figure).
- Extending or lowering the boom increases the working radius.
- Be alert to any sign of overloading when performing such operations.

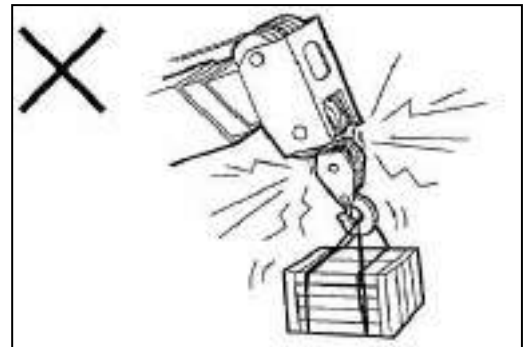

- Before moving a suspended load, ensure that there is no danger to persons in the immediate area. Passing a load over people is very dangerous and should be avoided (see right figure). Do not allow anyone to enter the area below the boom or the load.
- Move a load in the smallest possible working radius and as close to the ground as possible.

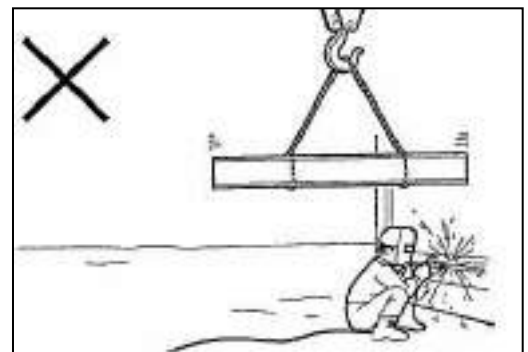

- Be careful when swinging a wide load. The load extremities may hit an obstacle or the machine. If necessary, use tethers (tag line) to control the position or movement of the load (see right figure).
- During a swing operation, the machine will not be automatically stopped even in the case of an overload. When swinging a load to a working area with a reduced capacity rating, be extremely careful not to allow the machine to be overloaded.
- Be aware of centrifugal force when swinging a load.

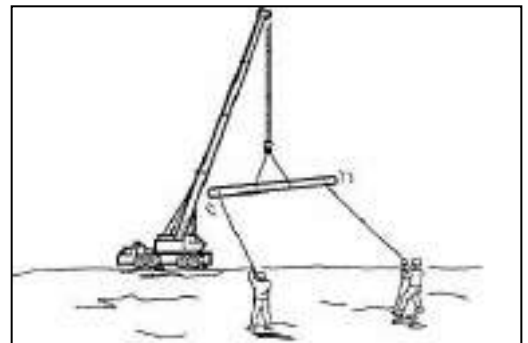

SAFETY INSTRUCTIONS

Centrifugal force works to increase the working radius. An increase in the working radius means a greater chance of overloading and resulting machine damage or overturning. Always swing slowly. If the swing is stopped suddenly, inertia will make the load over-swing, which then causes the load to rock back and forth (see right figure). Moreover, suddenly stopping a swing operation exerts a side load on the boom, which could damage the machine. Stop all swing operations slowly.

- Should the machine seem about to overturn, set the load on the ground by lowering it. Never raise or lower the boom suddenly. This action will not prevent an accident; rather it will increase the risk of overturning.
- Use sufficient care when mounting and stowing the jib. Failure to follow the specified procedure can damage the jib, or may cause the jib to drop, resulting in an accident (see right figure). Be sure to mount and stow the jib in the correct manner.
- Before leaving the cab for any reason, be sure to:
 - Lower the load to the ground and fully retract the boom
 - Place all the control levers in their neutral positions
 - Shut off the engine
 - Lock the cab door

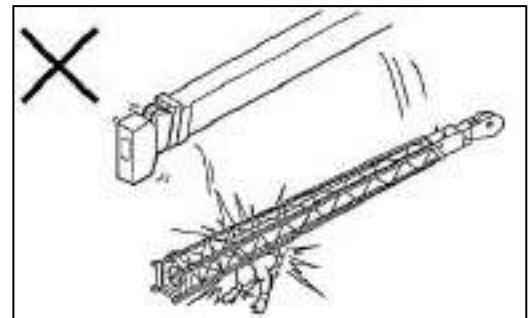
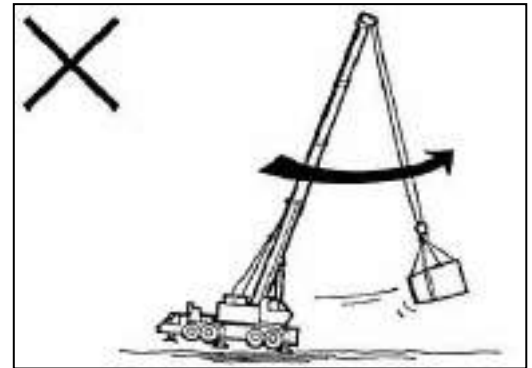

2.11 OPERATION NEAR POWER LINES

- Avoid operating near power lines. This machine has neither alarms to warn of electrical hazards nor is it equipped with insulating devices. Electric shock can result if the machine comes in contact with, or very close to, power lines, which can be fatal (see right figure).
- When traveling under power lines, make sure there is sufficient overhead clearance (minimum as required by law). Cross under power lines only when there is a sufficient distance between the lines and the top of the machine (see right figure).
- The legal regulations in force in the country where the machine is to be registered must be observed.
- The machine can be electrified in areas near radio or TV station towers. When working in any such area, carefully check the area and establish safety rules and working procedures before operating the machine.
- If operating near power lines is absolutely necessary, contact the power company to cut off the power.
- Observe the following precautions regardless of whether or not the power is cut off:
 - When an operation near power lines is planned, inform the power company well in advance.

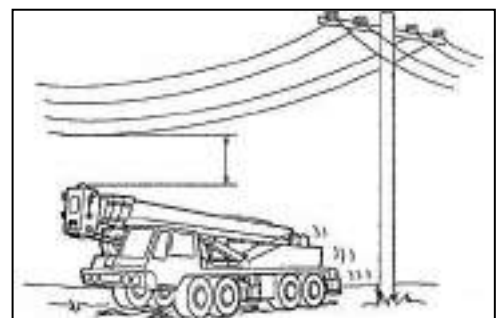
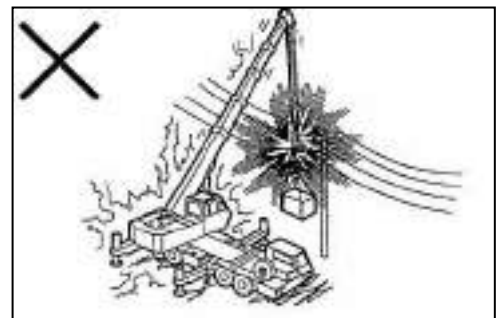

SAFETY INSTRUCTIONS

- Fence in the working area as necessary to prevent any parts of the machine or load from approaching a dangerous area near the power lines.
- Post a full-time watchperson when operating near power lines.
- Use of boom guards, insulated hook blocks, high-voltage line sensing devices, etc. does not assure safety. Boom guards cover only the head or a part of the boom, and are only partially effective in protecting the operator from electric shock (see right figure). An insulated hook block used between the boom and a load handling device has only limited insulating capabilities. A high-voltage line warning device can detect power only around the head of the boom and, therefore, does not provide warning if the wire rope or load is in close proximity to power lines. You cannot depend solely on these devices to protect you against electric shock. Failure to follow these precautions may result in serious injury or loss of life.
- Be sure to warn all personnel of the hazards involved. Allow only the personnel required for the job onto the work site.
- The victim of electric shock may be someone other than the operator. Rigging personnel and load handlers must not be allowed to touch wire ropes, load handling devices or the load, unless absolutely necessary. Remember that wire ropes and load handling devices are good conductors of electricity. Use dry fiber ropes as tethers. Electricity will circulate through ropes that are wet or soiled.
- Assume that all power lines are live, and always remember that these areas are dangerous.
- De-energizing and grounding the power lines while operating near power lines is the best method of protection and should be performed when possible. Confirm with the utility owner/operator that the power line has been de-energized and is visibly grounded at the work site.
- If de-energizing and grounding the power lines is not possible, the following precautions must be taken.
 - If voltage is unknown, clearance of 20 ft (6.10 m) must be maintained between the power lines and part of the equipment, load line, or load (including rigging and lifting accessories).
 - If voltage is known, determine the minimum clearance permitted according to the following table. The values in this table refer to the distance between the power lines and any part of the equipment, load line, or load (including rigging and accessories).



SAFETY INSTRUCTIONS

Minimum Required Clearance for Normal Voltage in Operation Near High Voltage Power Lines and Operation in Transit with No Load and Boom Lowered.	
Normal Voltage, kV (Alternating Current)	Minimum Required Clearance, m (ft) See Note 1
Operation Near High Voltage Power Lines	
To 50	3.05 (10)
Over 50 to 200	4.57 (15)
Over 200 to 350	6.10 (20)
Over 350 to 500	7.62 (25)
Over 500 to 750	10.67 (35)
Over 750 to 1000	13.72 (45)
Over 1000	(as established by the utility owner/operator or registered professional engineer who is a qualified person with respect to electrical power transmission and distribution)
Operation in Transit with No Load and Boom or Mast Lowered	
Up to 0.75	1.22 (4)
Over .75 to 50	1.83 (6)
Over 50 to 345	3.05 (10)
Over 345 to 750	4.87 (16)
Over 750 to 1000	6.10 (20)
Over 1000	(as established by the utility owner/operator or registered professional engineer who is a qualified person with respect to electrical power transmission and distribution)
<p>Note 1: Environment conditions such as fog, smoke, or precipitation may require increased clearances.</p>	

NOTE

◆ The power line safety instructions in this manual are not comprehensive. The local laws and regulations where the crane is registered stipulating the required power line clearance must be observed.

- Always keep all crane parts (boom, jib, wire rope, etc.) and load more than the required distance from power lines (see right figure). Should the crane be closer to power lines than the allowable distance, the operator may receive an electric shock that could be fatal, even if no machine part or the load is actually in contact with a power line.
- Power lines may swing in the wind and can shorten the distance between them and the machine. Be sure to take this into account and position the machine at a sufficient distance.
- Be alert to every possible danger. The primary safety rule is to operate slowly and carefully.
- Do not place a load beneath or near power lines.

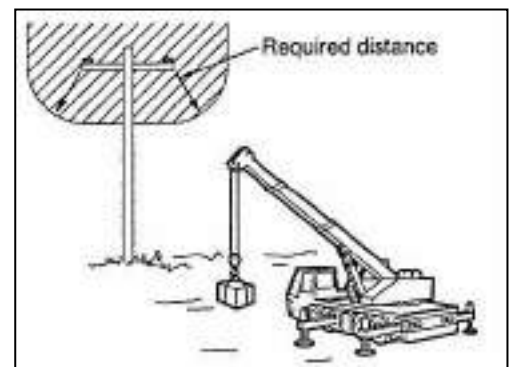

SAFETY INSTRUCTIONS

2.11.1 Grounding the Crane

Grounding the machine has little or no effect in preventing electric shock accidents. Its effectiveness varies depending on the length and thickness of the lead, condition of the ground, and intensity of the electric current and voltage. In addition, a grounded machine may produce an intense arc if it touches a power line.

Should the machine or load touch a power line, act as follows:

- Keep calm and do not leave the cab. A mistake may directly result in loss of life. Warn all personnel not to touch the machine or load, and to keep clear of them.
- If the machine is still operative, remove the crane from the danger zone by driving away or by slewing or adjusting the boom.
- Request persons outside of the danger zone to shut off the power supply.
- Break contact by moving in the direction opposite to that which caused the contact. Remember that an arc, once it has occurred, will extend over a distance much greater than expected before it breaks. Continue moving the machine, without stopping, until the arc breaks, and at least the minimum required distance is gained away from the power lines.
- If the machine is not on fire and no arc is passing through the cabin but the machine cannot be detached from the power lines, wait in the operator's seat until the power is cut off.
- If you must get out of the machine, jump directly from the cab as far as possible after making sure that the place to land on is safe. Never touch the crane and the ground at the same time. Touching other parts of the machine when you descend will cause electric shock (see right figure).
- After moving away from the power lines, carefully check the machine for possible damage. Before restarting operation, contact an authorized Tadano distributor or dealer to discuss the measures, and inspection and repairs required.

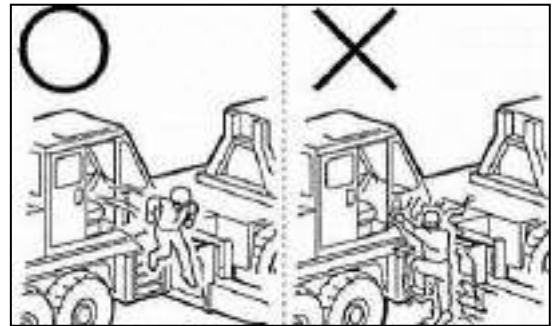

2.11.2 Inspection Measures

Inspection measures are required after an electric shock or a lightning strike.

After an electric shock or a lightning strike, check the electrical and electronic components for proper working order. Check the ball bearing slew device for damage and smooth motion.

SAFETY INSTRUCTIONS

2.12 OPERATION IN WIND AND LIGHTNING

Be sufficiently cautious when working in winds or sharp gust. Stop lifting if the maximum wind velocity exceeds 20 mph (9 m/sec). Retract and lower the boom fully, and activate the swing brake.

The table below lists wind speed ranges and the ground conditions for each range:

Wind Speed: mph	Wind Speed: m/sec	Ground Conditions
12-18	5.5-8.0	Dust is raised, paper swirls up and small branches sway.
18-24	8.0-10.8	Shrubs with leaves start swaying. Wave crests are apparent in ponds or swamps.
24-31	10.8-13.9	Tree branches move. Power lines whistle. It is difficult to open an umbrella.
31-38	13.9-17.2	Whole trees sway. It is difficult to walk against the wind.

Even a moderate wind with a maximum momentary gust velocity not exceeding 20 mph (9 m/sec) must not be underestimated. The higher above ground, the greater the wind speed is. This phenomenon is especially pronounced in city areas where high-rise buildings are clustered together.

The influence of wind on machine stability is directly proportional to the size and lifted height of the load and the length of boom. Lifting a large-area load, such as a billboard, on a windy day is dangerous because the load can strike a worker or building (see right figure). If the load is blown in a direction that increases the working radius, it may cause an overload, leading to a damaged boom or jib, or overturning of the machine.

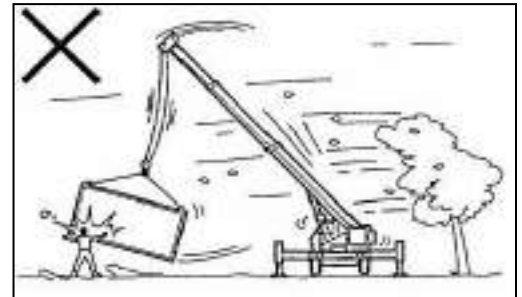

If there is a likelihood of lightning, stop operation and stow the boom.

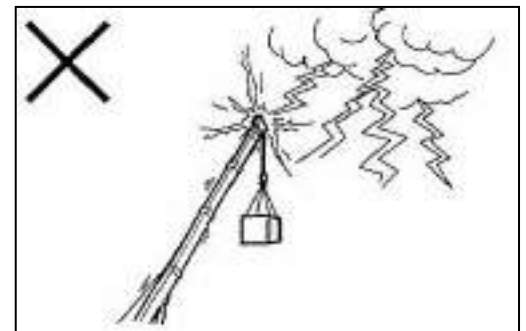

SAFETY INSTRUCTIONS

2.13 OPERATION NEAR PIPELINES



Particular caution is required in the area of exposed pipelines. Damage to such lines and any resulting leakage may have serious consequences.

Before crane work begins, make sure which fluids are transported in the supply lines. To this effect, the operating company involved must definitely be contacted.

If the lines contain substances that imply a hazard to the environment or to health, all the necessary safety measures must be stipulated in cooperation with the operating company.

Such work should only be performed with the help of assistants. If necessary, the assistant must also be familiar with all the safety precautions. Before work begins, hand signals must be defined for communication. The assistant must have full view of the entire working area, and be in constant eye contact with the operator.

2.14 OPERATION IN COLD WEATHER

- Remove snow or ice on the machine before operation; it is especially important to remove any accumulation on the boom, as it could fall and injure someone when the boom is moved.
- Before lifting in freezing temperatures, make sure that the load is not frozen to the ground or to any other object; attempting to lift a load that is frozen to the ground can result in severe overloading.
- Do not let bare skin come in contact with the machine's metallic parts when the temperature is below freezing. Skin could be frozen to the metallic surface, if any moisture is present.

2.15 LEAVING THE CRANE OUT OF SERVICE

- Never leave a load suspended from the crane when not in service.
- Always fully retract the boom and lower the boom to a horizontal position when crane is not in service.
- Remove the ignition switch key and lock the cab door when not in service to prevent accidental or unintended operation of the crane.
- A battery disconnect switch is provided inside the rear covers (engine side) to allow the battery to be disconnected from the engine to prevent unexpected or unintentional startup of the engine. It is recommended to disconnect the batteries if the crane will be unused for more than one week.

2.16 POTENTIAL CAUSES OF ACCIDENTS

The majority of the damage caused during operation of mobile cranes is due to operating errors, whereas the minority is due to inadequate maintenance of the machine.

Consequently, to avoid accidents, it is important for the operator to be thoroughly trained in the operation, application, and maintenance of the crane.

The operator must be able to recognize any risks endangering the health and safety of himself and other people, and to take the appropriate measures to avoid such risks.

2.16.1 Operation Faults That May Cause Accidents

Such causes and faults may occur during crane operation for the following reasons:

- The crane is not configured and on level ground as specified in the load chart.
- The ground conditions are not sufficient to support the weight of the crane and the load to be lifted.

SAFETY INSTRUCTIONS

- The crane is installed too close to the edge of slopes or excavations.
- The crane is driven over excessively sloped or excessively uneven ground.
- The rope becomes slack on the hoist winch.
- Loads are improperly secured.
- Errors are committed during operations (e.g. too fast braking of the load, fast slewing of the boom under load, diagonal pulling of loads, or breaking them loose).
- Excessive loads imposed on the crane.
- Excessive wind loads acting on the load and/or the crane.
- The counterweight has not been selected according to the load chart.
- The RCI is not set to the actual configuration of the crane.
- The RCI and other safety devices are faulty or not in operation.
- The admissible loads or the working radii specified in the load charts are exceeded.
- During crane work diagonal tensile stress is applied to the boom, especially in a lateral direction.
- Any obstacles impeding the crane's movements are ignored.
- The suspended load starts to swing due to negligent crane operation.
- Sudden release of lifted loads may cause the crane to tip over backwards.
- The crane operator tries to lift too heavy loads from the ground using the boom elevation. In this case, the RCI will emit an "overload" warning signal; however, the movement "boom elevation up" is not stopped, as this is a movement that tends to reduce the load moment.
- The minimum clearance from live overhead lines is no longer maintained during crane work.



If these items are not observed, there is a considerable risk of accidents. Before the operator starts work, he has to check whether the safety measures as specified above have been carried out.



❖ When there is a risk of lightning, stop crane work immediately and retract the boom.

2.16.2 Servicing Faults That May Cause Accidents

- Lack of oil, grease or anti-freeze agent in the various assemblies.
- Unspecified lubricants and oils used (not on chart of approved lubricants).
- Lack of anti-freeze agent to protect the engine in winter.
- Loosening of screw couplings; make sure that the correct tightening torques is adhered to on retightening.
- Insufficient maintenance, which may result in an unexpected malfunction of assemblies (e.g. of the braking and steering systems).
- Worn ropes that are ready for discarding and may break suddenly.

SAFETY INSTRUCTIONS

- Deficiencies in the hydraulic system (e.g. frayed hoses).
- Defective or unsatisfactorily operating safety devices (e.g. load moment limiters or hoist limit or winch limit switches).
- The steel structures, welded components, and parts subject to increased stress are not examined visually.



The operator must have undergone thorough training with the crane to be able to detect and to avoid all dangers that may occur in the course of operation. If work is not carried out in an expert manner, there is an increased risk of accidents.

2.17 FIRE, SMOKE, INFLAMMATION AND EXPLOSION HAZARDS

- Use the crane only in areas where there is no risk of explosion.
- Do not smoke when handling fuels or consumables and during maintenance work on the batteries.
- Do not handle fire or open flames on the crane.
- Due to the risk of burning, maintenance never perform work on hot machines; work only after they have cooled down.
- In the vicinity of hot surfaces, insulating or sound-absorbing mats contaminated by fuel, oil or grease have a considerable risk of fire; thus, they must be replaced by new, clean mats.

OPERATING INSTRUCTIONS

SECTION 3. OPERATING INSTRUCTIONS

3.1 LOCATION OF WARNING AND INSTRUCTION MARKINGS (US)

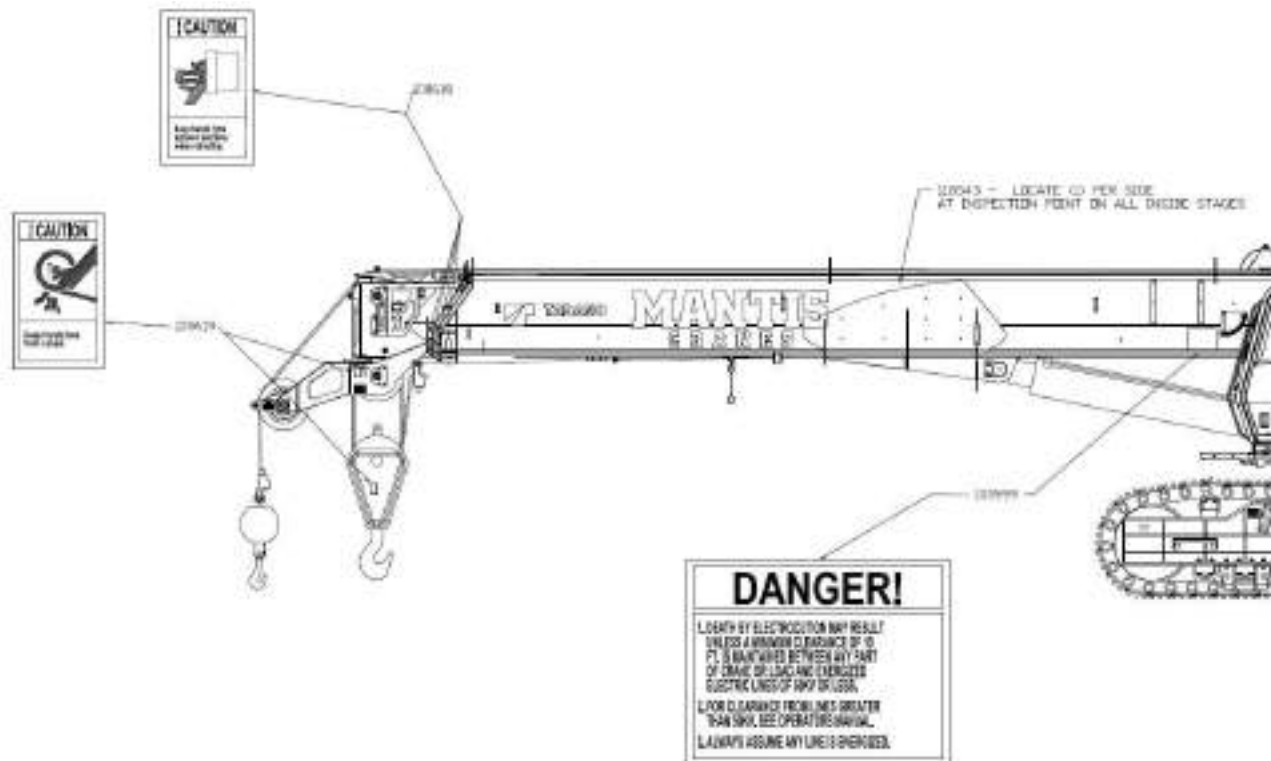



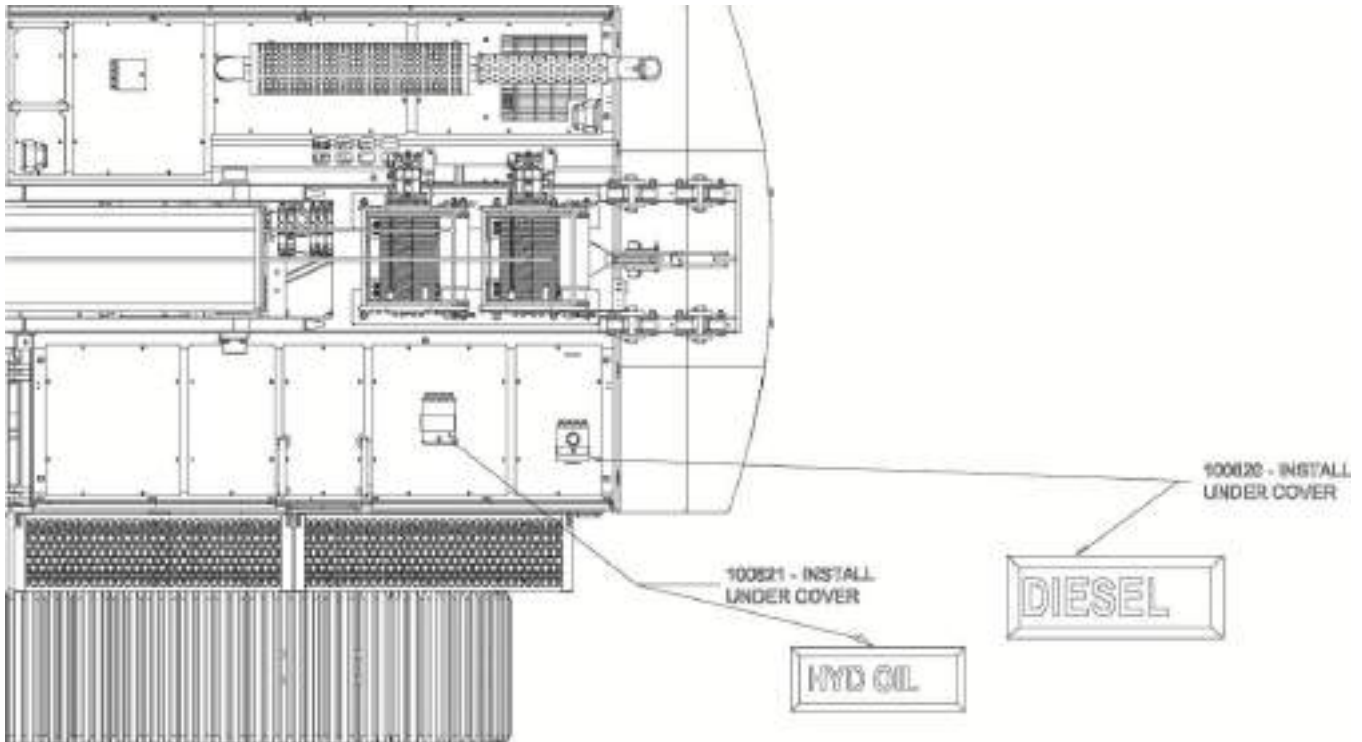
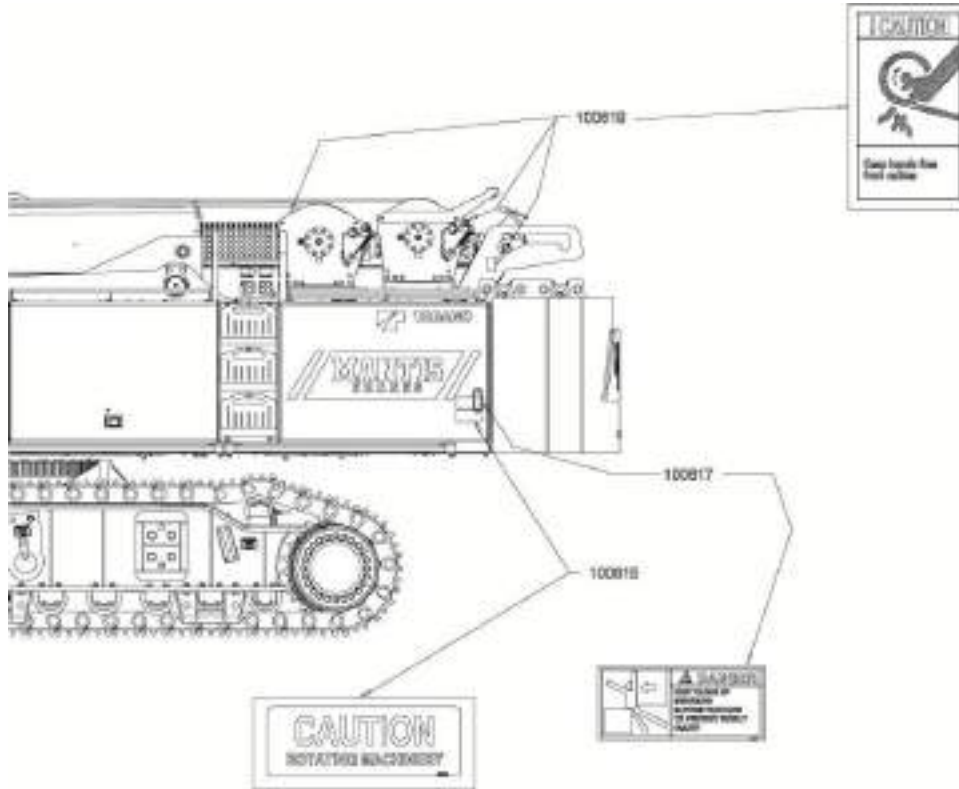

OPERATING INSTRUCTIONS

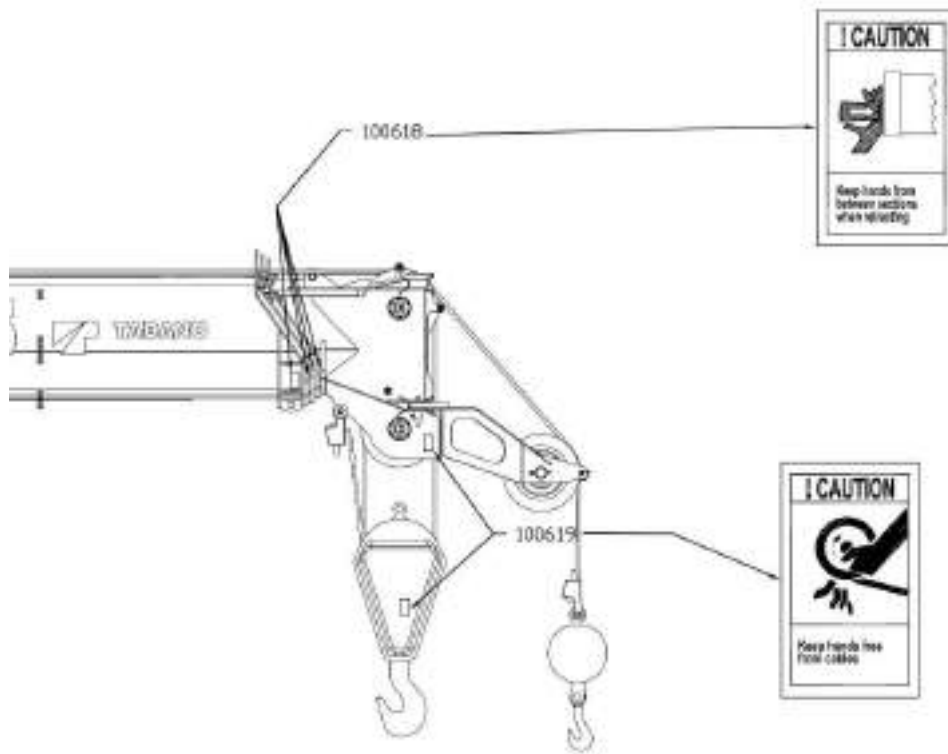
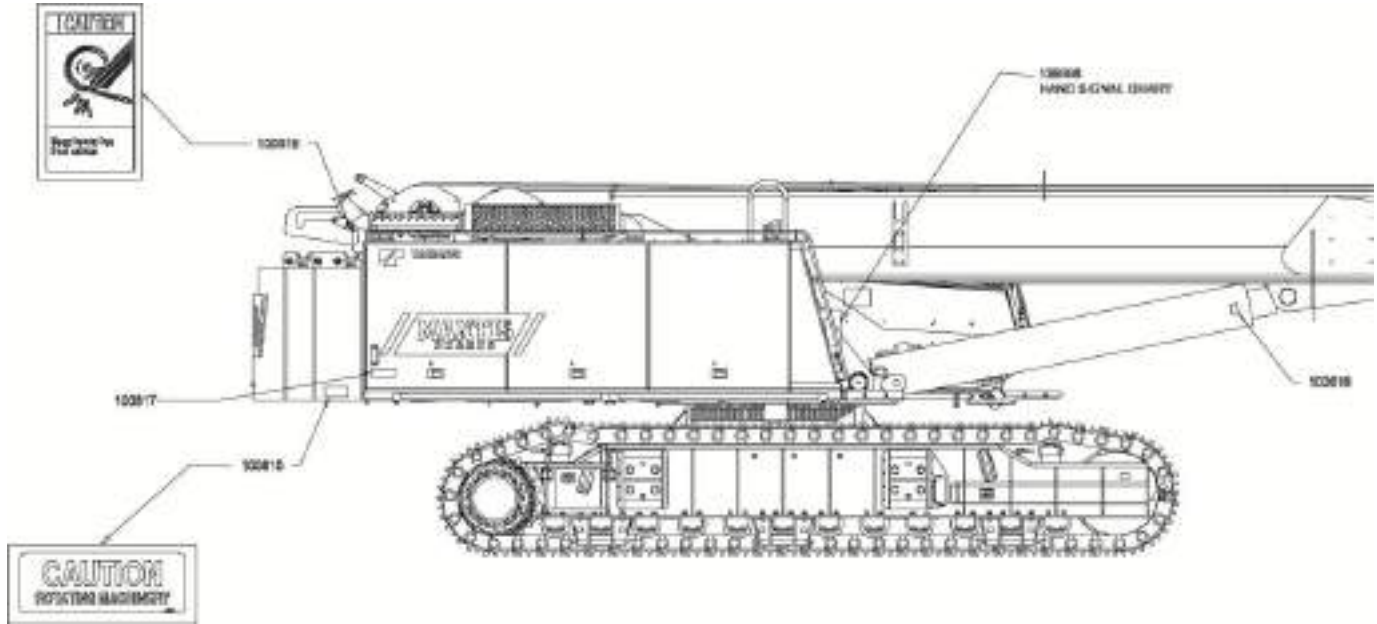



OPERATING INSTRUCTIONS



OPERATING INSTRUCTIONS





QUANTITY PER CRANE	TADANO MANTIS PART NUMBER	DESCRIPTION	GRAPHIC
1	100599	DECAL, DEATH BY ELECTROCUTION (LG)	
2	100615	DECAL, CAUTION, ROTATING MACHINERY	
2	100617	DECAL, DANGER, KEEP CLEAR OF SWINGING MACHINERY	
10	100618	DECAL, DANGER CRUSHING HAZARD	
8	100619	DECAL, DANGER CABLE PINCH POINT	

OPERATING INSTRUCTIONS







QUANTITY PER CRANE	TADANO MANTIS PART NUMBER	DESCRIPTION	GRAPHIC
1	100620	DECAL, DIESEL FUEL ONLY	
1	100621	DECAL, HYDRAULIC FLUID ONLY	
6	118543	DECAL, WARNING VISUAL INSPECTION	N/A
1	136698	DECAL, HAND SIGNAL CHART	

OPERATING INSTRUCTIONS



3.2 LOCATION OF WARNING AND INSTRUCTION MARKINGS (EXPORT)

ITEM #	QTY PER CRANE	PART #	DESCRIPTION	GRAPHIC
1	1	136529	DECAL, BATTERY DISCONNECT, CE COMPLIANT	
2	4	136616	DECAL, CG AND WEIGHT, CE COMPLIANT	
3	1	136530	DECAL, WARNING, HOT SURFACE, CE COMPLIANT	
4	11	136338	DECAL, WARNING, CRUSHING HAZARD, CE COMPLIANT	
5	8	136339	DECAL, WARNING, ENTANGLEMENT, CE COMPLIANT	

OPERATING INSTRUCTIONS

ITEM #	QTY PER CRANE	PART #	DESCRIPTION	GRAPHIC
6	8	136636	DECAL, LIFTING POINT, CE COMPLIANT	
7	2	136336	DECAL, WARNING ,KEEP AWAY FROM SWINGING STRUCTURE, CE COMPLIANT	
8	8	136600	DECAL, TIE-DOWN POINT, CE COMPLIANT	
9	8	136537	DECAL, GROUNDING LOCATION	
10	2	136658	DECAL, WARNING ELECTRICAL HAZARD, POWER LINES	
12	4	136536	DECAL, WARNING, CRUSH/PINCH HAZARD, CE COMPLIANT	

OPERATING INSTRUCTIONS

ITEM #	QTY PER CRANE	PART #	DESCRIPTION	GRAPHIC
13	2	136725	SAFETY MARKING, RIGHT HANDED, REAR CWT	 RED and WHITE Diagonal Striping per DIN 30710
14	2	136726	SAFETY MARKING, LEFT HANDED, REAR CWT	
15	1	136727	SAFETY MARKING, BOOM, FRONT	
16	1	136728	SAFETY MARKING, BOOM HEAD, RIGHT SIDE	
17	1	136729	SAFETY MARKING, BOOM HEAD, LEFT SIDE	
18	1	136674	DECAL, DIESEL FUEL, CE COMPLIANT	
19	1	136675	DECAL, HYDRAULIC OIL, CE COMPLIANT	

OPERATING INSTRUCTIONS

3.3 LOCATION OF CAB WARNING AND INSTRUCTION MARKINGS

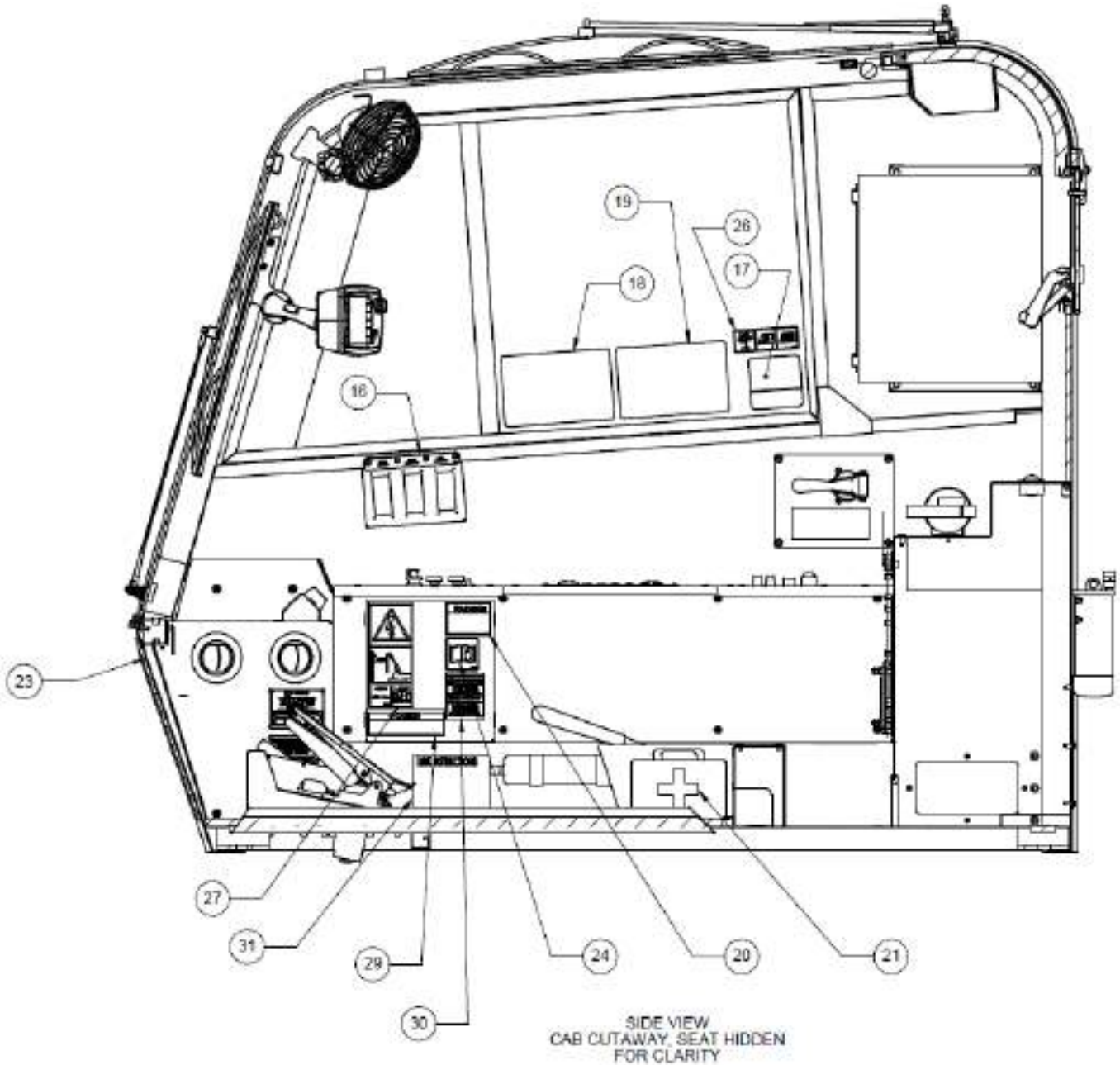

OPERATING INSTRUCTIONS

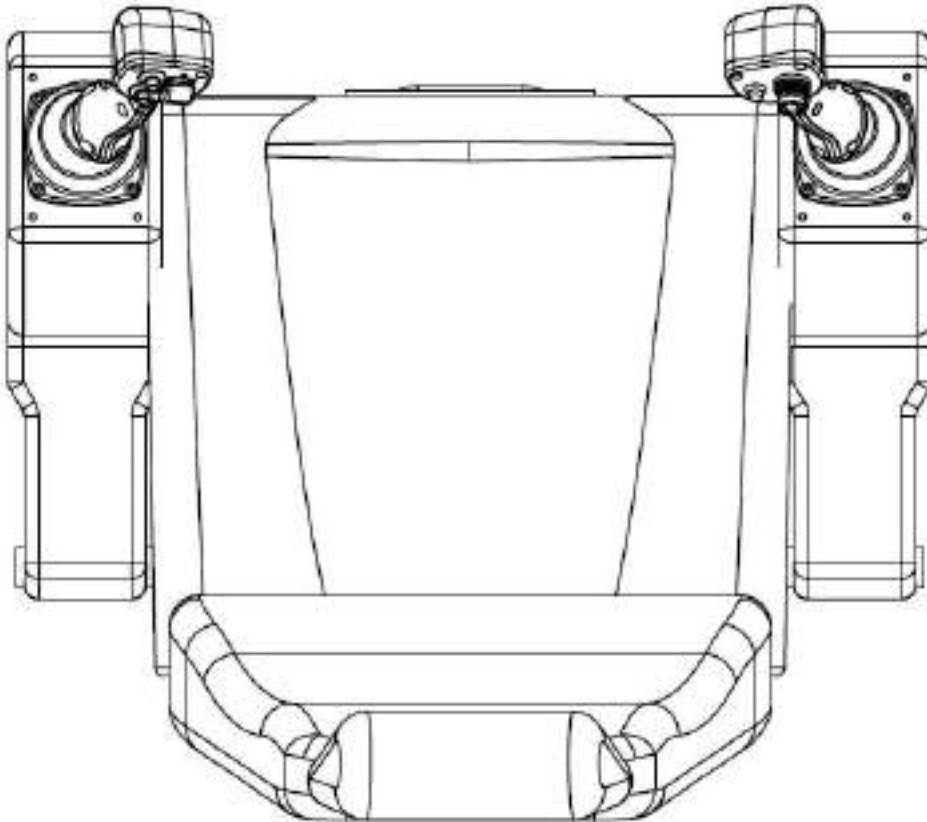
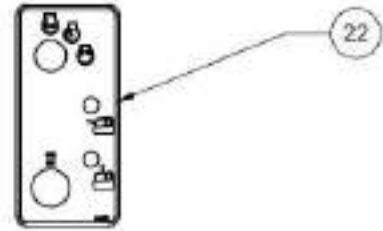

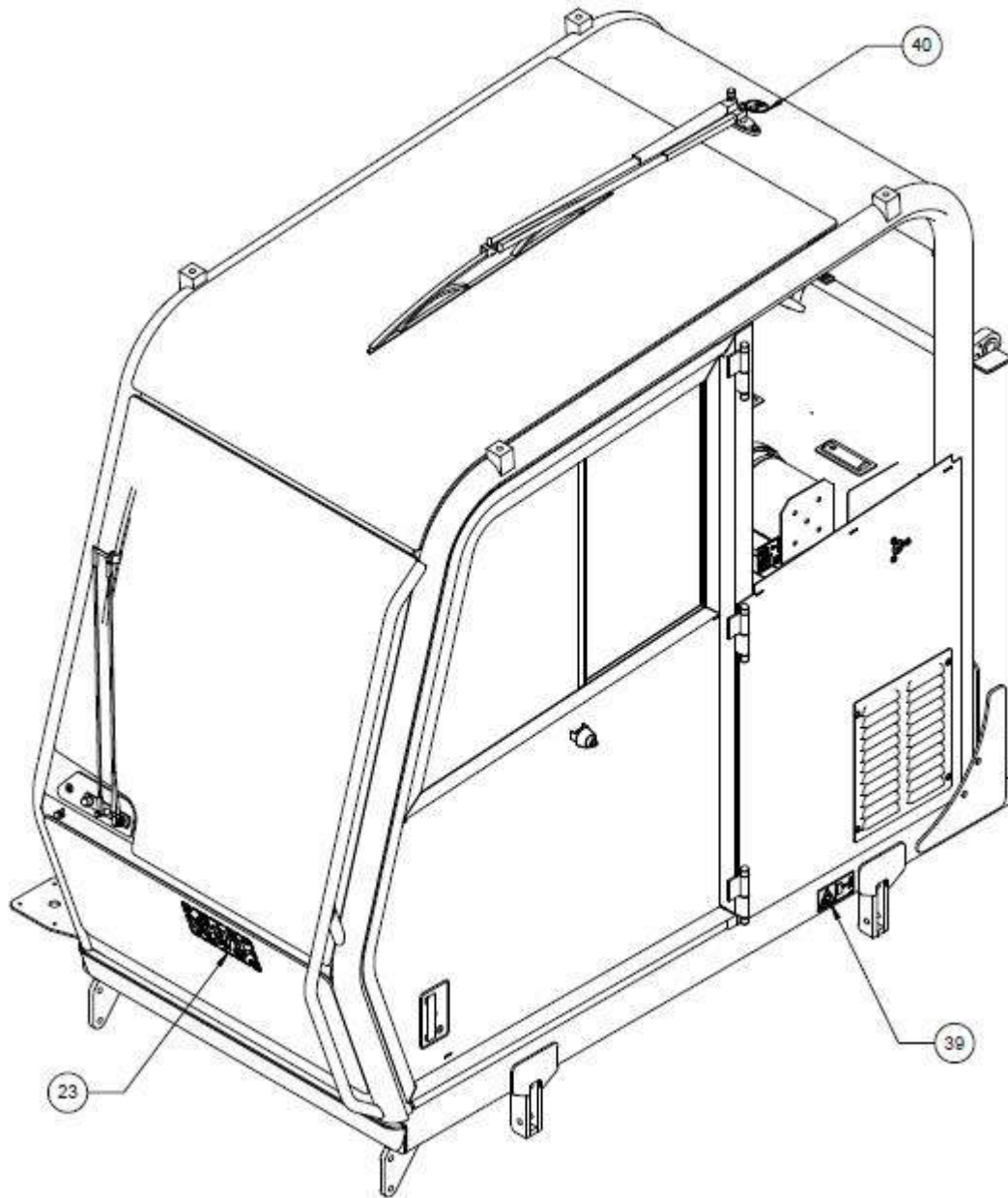

OPERATING INSTRUCTIONS





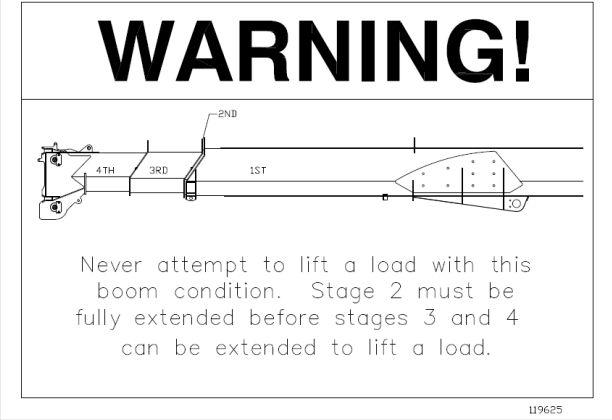

OPERATING INSTRUCTIONS

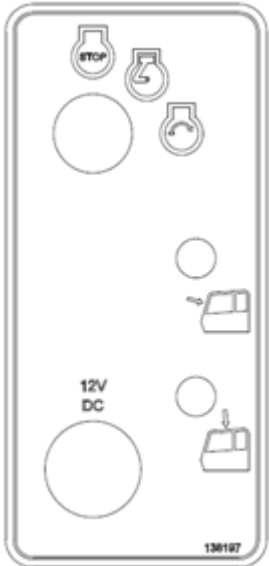
Item Number	QTY Per Crane	Part Number	Description	Graphic
16	1	132332	DECAL, WORK LIGHT CONTROL PANEL	
17	1	130184	DECAL, HEAT VALVE, ENGINE, CAB	
18	1	139322	DECAL, JOYSTICK CONTROL STANDARD MODE, OEM JOYSTICKS	
19	1	139323	DECAL, JOYSTICK CONTROL TRAVEL MODE, TRAVEL MODE	

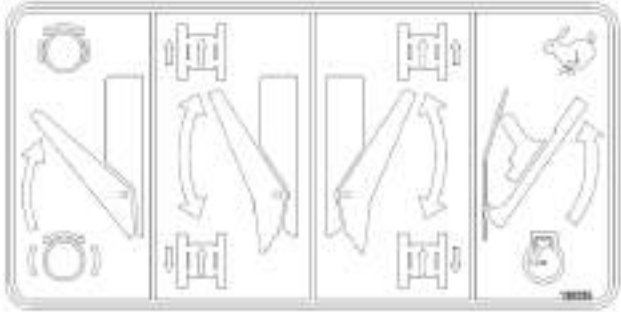

OPERATING INSTRUCTIONS

Item Number	QTY Per Crane	Part Number	Description	Graphic
20	1	119625	DECAL, WARNING NEVER ATTEMPT TO LIFT A LOAD WITH THIS BOOM CONDITION (4 STAGE BOOMS ONLY)	
21	1	136532	DECAL, FIRST AID KIT, CE COMPLIANT	
22	1	138197	DECAL, IGNITION, WIPERS, 12V, CE COMPLIANT	

OPERATING INSTRUCTIONS

Item Number	QTY Per Crane	Part Number	Description	Graphic
23	1	136335	DECAL, PEDAL CONTROLS CAN CONTROLS CE COMPLIANT	
24	1	136531	DECAL, STORAGE, OPERATOR'S MANUAL	
26	1	136577	DECAL, EMERGENCY EXIT, WINDOW, CAB	
27	1	136657	DECAL, WARNING ELECTRICAL HAZARD, POWER LINES	
30	1	103560	DECAL, WARNING DO NOT OPERATE MACHINE	

OPERATING INSTRUCTIONS

Item Number	QTY Per Crane	Part Number	Description	Graphic
31	1	100601	DECAL, LUBE INSTRUCTION	<div style="border: 1px solid black; padding: 10px; width: fit-content; margin: auto;"> <h3 style="margin: 0;">LUBE INSTRUCTIONS</h3> <p style="margin: 0; text-align: center;">ROTATE CRANE SLOWLY WHILE PUMPING ONE COMPLETE CARTRIDGE OF EP GREASE WITH MOLYBDENUM DISULFIDE. DO EVERY 2 WEEKS WHEN MACHINE IS IN SERVICE.</p> </div>
39	1	136615	DECAL, WARNING, PINCH POINT, CAB FRAME,	
40	1	136555	DECAL, DO NOT STEP, CE COMPLIANT	

OPERATING INSTRUCTIONS

3.4 LOAD MOMENT INDICATOR (AML)

Refer to Appendix A for Load Moment Indicator (AML) operating instructions.

3.5 DASH/CONTROL PANELS

The 10010MX operator controls are grouped into eight main functional groups as follows:

- Air Conditioning/Heat/Fan Controls
- Ignition/Wipers/12V Outlet
- Switch Panel
- Foot Pedals; Throttle/Swing Brake/Travel Controls
- AML-C Display
- Cab Display
- Left Hand Joystick; Swing Right/Left Controls/Auxiliary Winch Lower/Raise
- Right Hand Joystick; Telescope Out/In Control Main Winch Control/Boom Hoist Raise/Lower



Air Conditioning/Heat/Fan Controls

OPERATING INSTRUCTIONS

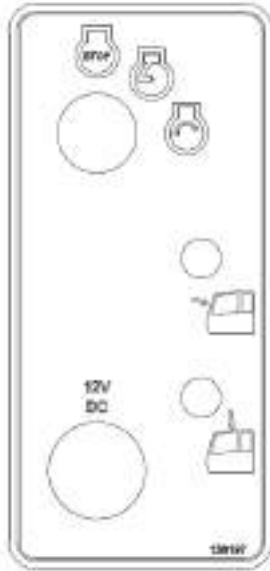

Ignition/Wipers/12V Outlet



Switch Panel



Foot Pedals

OPERATING INSTRUCTIONS



AML-C display



Left Hand Joystick



Right Hand Joystick

OPERATING INSTRUCTIONS

3.6 CAB DISPLAY

The display in the cab provides the operator with camera views and information and warnings from the engine and hydraulic system. The operator may use the display to make selections regarding engine speed, operating mode, and camera selection. Further, the display offers a service tool for adjustment of certain parameters.

This display offers three operating ranges:

1. The default is the **Engine page**, which includes gauges for engine speed, engine hours, coolant temperature, fuel level, and voltage level. From this page, the operator can view current operating mode and change the mode.
2. The next page is the **Hydraulic page**, which includes gauges for pump, pilot, and load sense pressure, hydraulic fluid level, and hydraulic fluid temperature. Both pages have a small camera view, and the next page has a large camera view. All pages show system status and warnings across the top and allow the operator to control the engine speed, select winch or rear view camera, select free swing on or off, silence alarm, or go to the service page.
3. The **Service page** allows the operator to adjust default settings, display and backlight intensity, real time clock and select US or metric units. The **Valve Adjustment page** can be accessed from this page, which allows the operator to adjust maximum function speed, start ramp, and stop ramp for each direction of each function.



Crane operation changes are significantly based on setting of the modes. Confirm status of the following modes on the display before operation.

- **Operation Mode:** Joystick function changes between “standard crane” and “travel.” Carbody jack mode enables the pendant.
- **Free Swing:** In free swing mode, when the swing park brake is released, the upper structure will freely swing based on gravity. It is recommended to always apply the swing service brake before releasing the park brake.
- **Fine Control:** All functions operate at < 50% of maximum speed.

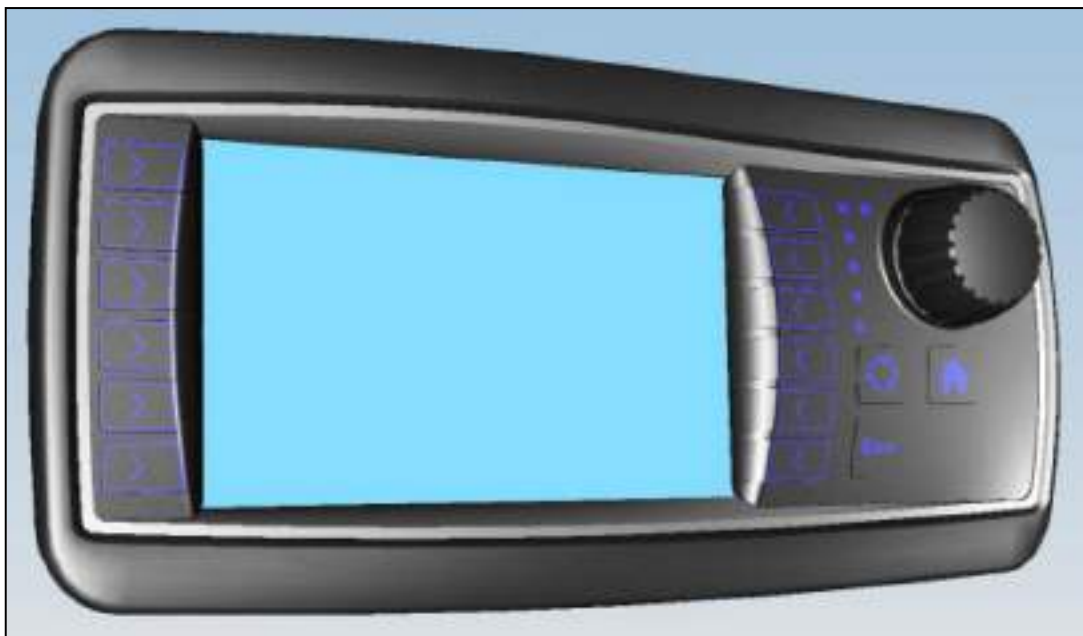

OPERATING INSTRUCTIONS

3.6.1 Operating Pages



Engine Page

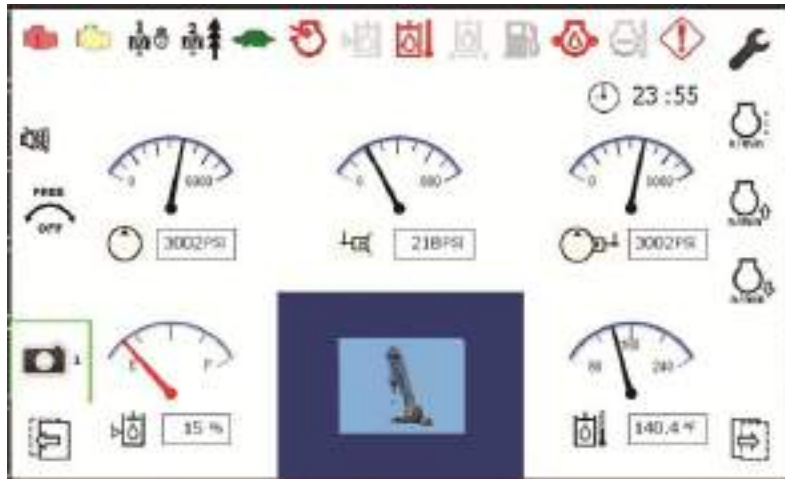

Hydraulic Page



Camera Page

OPERATING INSTRUCTIONS

3.6.2 Service Pages

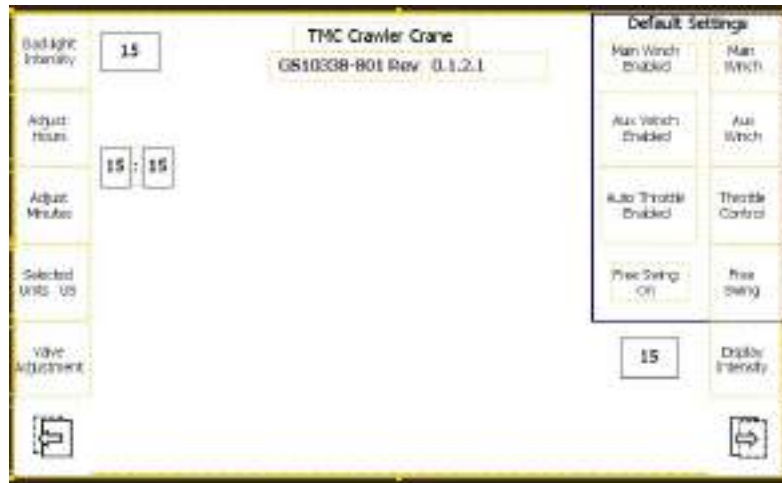

Service Page

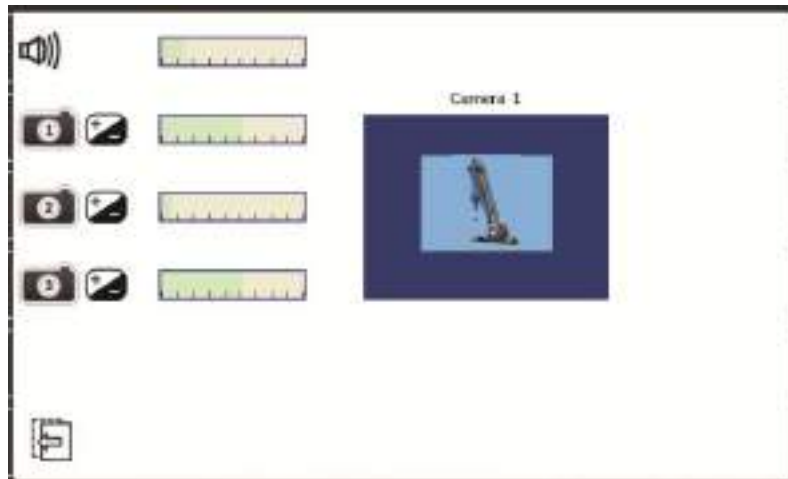











Display Service Page











Valve Adjustment Page

OPERATING INSTRUCTIONS





3.6.3 Display Icons

Icon	Description	Type
	Engine Shut Down (inactive when gray): Severe problem with engine. Return load to a safe place and shut down engine as soon as possible.	Warning
	Engine Error (inactive when gray): Minor problem with engine. Service engine soon.	Warning
	Main winch (1) status is disabled: Function is disabled in both directions due to operator selection on the display service screen.	Status
	Main winch (1) status is last wrap shutdown: Function disabled in the lower direction to keep a minimum number of wraps on the drum.	Status
	Main winch (1) status is low speed: Function status is normal; operator has selected low speed range with the button on the joystick.	Status
	Main winch (1) status is high speed: Function status is normal; operator has selected low speed range with the button on the joystick.	Status
	Auxiliary winch (2) status is disabled: Function is disabled in both directions due to operator selection on the display service screen.	Status
	Auxiliary winch (2) status is last wrap shutdown: Function disabled in the lower direction to keep a minimum number of wraps on the drum.	Status
	Auxiliary winch (2) status is low speed: Function status is normal; operator has selected low speed range with the button on the joystick.	Status
	Auxiliary winch (2) status is high speed: Function status is normal; operator has selected high speed range with the button on the joystick.	Status
	Fine control is active (inactive when gray): All functions operate at < 50% of maximum speed. Operator has selected fine control with button on left joystick.	Status







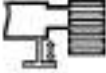

OPERATING INSTRUCTIONS

Icon	Description	Type
	Engine Air Intake Filter is restricted (not restricted when gray): Check and service air filter.	Warning
	Low hydraulic fluid level (level is normal when gray): This is associated with the hydraulic fluid level gauge. Check hydraulic fluid level in reservoir and check system for leaks. Add fluid to reservoir and repair any leaks.	Warning
	High hydraulic fluid temperature (temperature is normal when gray): This is associated with the hydraulic temperature gauge. Hydraulic fluid temperature exceeds 176°F (80°C). Check cooler operation and allow system to cool, either by shutting off engine or allow engine to run at idle with all functions in neutral.	Warning
	Hydraulic filter clog (not clogged when gray): Either the in tank return filter or the inline pilot filter is clogged. Touch the icon to verify which is clogged and replace element accordingly. Note this warning may come on during cold weather operation during higher flow functions until fluid reaches operating temperature.	Warning
	Low diesel fuel level (level is normal when gray): This is associated with the fuel level gauge. Add fuel to tank.	Warning
	Low engine oil pressure (normal when gray): Shut down engine as soon as possible to determine the cause and repair before restarting the engine.	Warning
	High engine coolant temperature (normal when gray): This is associated with the coolant temperature gauge. Shut down engine as soon as possible to determine the cause and repair before restarting the engine.	Warning
	Control system error (no error when gray): Module or component is offline or not functioning properly. Use diagnostic tools to determine problem and repair.	Warning
	Go to Control System Service Page: View page to change defaults, backlight and display intensity, time, units, or valve settings.	Soft key/ Touch screen

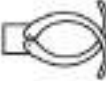
OPERATING INSTRUCTIONS

Icon	Description	Type
	<p>Cycle through preset engine speeds of low, medium, and high (900, 1800, & 2100 rpm):</p> <p>When auto-idle mode is OFF (pushbutton in side console is red) and all functions are in neutral, engine will run constantly at speed selected on display. When auto-idle mode is ON (button is green), engine will run at low idle until a function is activated, then engine will increase to selected speed. After all controls are returned to neutral, engine speed will return to low idle after a delay.</p>	<p>Soft key/ Touch screen</p>
	<p>Increase engine speed:</p> <p>A single press will step up the engine speed. If it is held, the engine speed will continue to increase up toward maximum speed until it is released. When auto-idle mode is OFF (pushbutton in side console is red) and all functions are in neutral, engine will run constantly at speed selected on display. When auto-idle mode is ON (button is green), engine will run at low idle until a function is activated, then engine will increase to selected speed. After all controls are returned to neutral, engine speed will return to low idle after a delay.</p> <p>A red "!" in this icon indicates function speed is currently limited by engine speed and the operator may wish to increase the engine speed in order to increase the function speed.</p>	<p>Soft key/ Touch screen</p>
	<p>Decrease engine speed:</p> <p>A single press will step down the engine speed. If it is held, the engine speed will continue to decrease down toward low idle until it is released. When auto-idle mode is OFF (pushbutton in side console is red) and all functions are in neutral, engine will run constantly at speed selected on display. When auto-idle mode is ON (button is green), engine will run at low idle until a function is activated, then engine will increase to selected speed. After all controls are returned to neutral, engine speed will return to low idle after a delay.</p>	<p>Soft key/ Touch screen</p>
<p>Mode</p>	<p>Scroll through available modes:</p> <p>Crane and travel are standard modes; other modes may be available based on optional equipment (i.e. Carbody Jack, Auger, Pole Claw, or Radio Remote).</p>	<p>Soft key/ Touch screen</p>
	<p>Current mode selection is Crane (default):</p> <p>Optimal for normal operation of crane functions.</p> <p>See joystick decal for control configuration.</p> <p>Push mode button to scroll through available modes.</p>	<p>Status</p>
	<p>Current mode selection is Travel:</p> <p>Optimal for long distance travel operation or straight travel.</p>	<p>Status</p>

OPERATING INSTRUCTIONS

Icon	Description	Type
	See joystick decal for control configuration. Push mode button to scroll through available modes.	
	Current mode selection is Carbody Jacks: (optional) Carbody Jack control pendant is enabled and travel is disabled. See joystick decal for control configuration. Push mode button to scroll through available modes.	Status
	Current mode selection is Auger (optional): Main Winch is disabled, Auger is enabled. See joystick decal for control configuration. Push mode button to scroll through available modes.	Status
	Current mode selection is Pole Claw (optional): Pole Claw functions are enabled. See joystick decal for control configuration. Push mode button to scroll through available modes.	Status
	Engine hours: Indicates the accumulated engine hours	Status
	Go to next page	Soft key/ Touch screen
	Go to previous page	Soft key/ Touch screen
	Scroll through available camera views	Soft key/ Touch screen
	Free swing is currently off: Press to toggle between on and off. Current status is displayed.	Soft key/ Touch screen
	Temporarily silence alarm: Alarm indicates item has gone to error state; check top row of display for details.	Soft key/ Touch screen







OPERATING INSTRUCTIONS

Icon	Description	Type
Main Winch	<p>Select default setting at startup for enable/disabling the winch: Operator can disable the winch to prevent inadvertent operation. Press to toggle selection.</p>	Soft key/ Touch screen
Main Winch Enabled	<p>Current default status: enabled or disabled</p>	Status
Aux Winch	<p>Select default setting at startup for enable/disabling the winch: Operator can disable the winch to prevent inadvertent operation. Press to toggle selection.</p>	Soft key/ Touch screen
Aux Winch Enabled	<p>Current default status: enabled or disabled</p>	Status
Throttle Control	<p>Select default setting at startup for auto idle: Operator may select based on preference. Note this is only the default; auto idle may always be turned on or off with the switch in the console panel.</p>	Soft key/ Touch screen
Auto Throttle Enabled	<p>Current default status: Enabled- crane will start up with auto idle on. Disabled- crane will start up with auto idle off.</p>	Status
Free Swing	<p>Select default setting at startup for dual mode swing: Operator may select free swing or not free swing based on preference. Note this is only the default; free swing may always be turned on or off with softkey on the display.</p>	Soft key/ Touch screen
Free Swing On	<p>Current default status: Free Swing On- crane will start up in free swing mode. Free Swing Off- crane will start up in not free swing mode.</p>	Status
Display Intensity	<p>Adjust intensity of the display: Press to select then use encode wheel to increase or decrease.</p>	Soft key/ Touch screen
Backlight Intensity	<p>Adjust backlight intensity of buttons on display and switch panel in console: Press to select then use encode wheel to increase or decrease.</p>	Soft key/ Touch screen
Adjust Hours	<p>Adjust hours for real time clock: Press to select then use encode wheel to increase or decrease.</p>	Soft key/ Touch screen

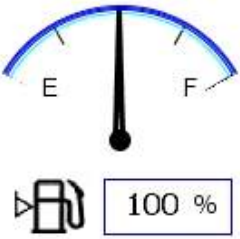
OPERATING INSTRUCTIONS

Icon	Description	Type
Adjust Minutes	Adjust minutes for real time clock: Press to select then use encode wheel to increase or decrease.	Soft key/ Touch screen
Valve Adjustment	Go to Valve Adjustment page: Service page for adjustment of max function speed, start ramp, and stop ramp.	Soft key/ Touch screen

Display Gauges

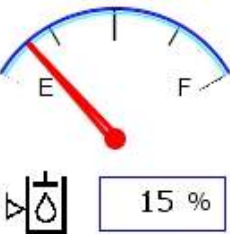
Gauge	Description	Gauge	Description
	Diesel fuel level (%) Indicate level of fuel in tank		Pump pressure (PSI or bar)
	Engine speed (rpm) Two needles: black & gray Black needle indicates actual engine speed Gray need indicates auto idle speed setting		Pilot pressure (PSI or bar)
	Coolant Temperature (°F or °C) Indicates temperature level of engine coolant		Load Sense pressure (PSI or bar) Indicates pressure of load sense signal to pump controller
	Battery voltage level (Volts) Indicates voltage level of battery and charging system		Hydraulic Fluid Level (%) Indicates level of fluid in reservoir

OPERATING INSTRUCTIONS

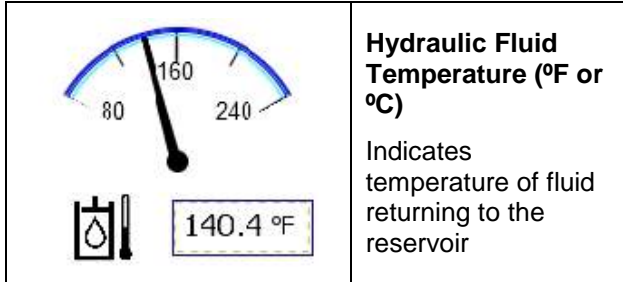



OPERATING INSTRUCTIONS







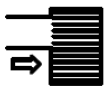



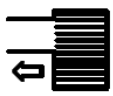

3.7 SWITCH PANEL

The switch panel located in the right console provides control for certain crane functions. The switches are backlit either green or red based on current status, and may flash to communicate crane status information. Backlight density may be adjusted through the display. Note that optional buttons may not be present based on crane configuration.



Icon	Description	Type	Standard/Optional	Red	Green	Flashing
	Std: Both Tracks Extend Opt: Left Track Extend	Momentary	Standard	Off	On	N/A
	Std: Both Tracks Retract Opt: Left Track Retract	Momentary	Standard	Off	On	N/A
	Std: N/A Opt: Right Track Extend	Momentary	Optional	Off	On	N/A

OPERATING INSTRUCTIONS

Icon	Description	Type	Standard/Optional	Red	Green	Flashing
	Std: N/A Opt: Right Track Retract	Momentary	Optional	Off	On	N/A
	Travel Enable	Maintained	Standard	Disabled	Enabled	N/A
	Overload Override	Momentary	Standard	Not Activated	Activated	Active Overload Condition
	A2B Override	Momentary	Standard	Not Activated	Activated	Active A2B Condition
	Last Wrap Override	Momentary	Optional	Not Activated	Activated	Active Last Wrap Condition
	Boom Hoist Up Override	Momentary	Optional	Not Activated	Activated	N/A
	Auto Idle On/Off	Maintained	Standard	Auto Idle Off	Auto Idle On	N/A
	Travel Speed High/Low	Maintained	Standard	Low Speed	High Speed	High Speed Disabled due to Hook Load & Boom Length
	Auger Latch Release	Momentary	Optional	Off	On	N/A
	Boom Tool Circuit On/Off	Maintained	Optional	Off	On	N/A
	Tool Circuit High Flow	Maintained	Optional	Off	On	N/A
	Tool Circuit Low Flow	Maintained	Optional	Off	On	N/A

OPERATING INSTRUCTIONS

3.8 ENGINE LEDs

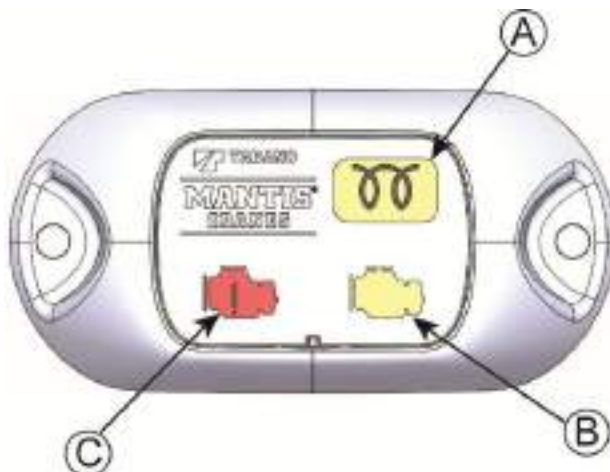

Three LEDs are located on the panel on the right hand side of the cab. If they turn on, follow the instructions below:

- A)** Wait to Start: Please wait until this light goes off before starting the engine.
- B)** Engine Error: Minor problem with engine. Service engine soon.
- C)** Engine Shut Down: Severe problem with engine. Return load to a safe place and shut down engine as soon as possible.

3.8.1 Startup Procedure

When starting the crane, two of the engine LEDs will turn on automatically, the engine error LED (B) and the engine shut down LED (C). The engine shut down LED will turn off first, followed by the engine error LED at approximately two second intervals. If one or both LEDs do not turn off automatically, this indicates a problem with the engine (see above).

OPERATING INSTRUCTIONS

3.9 IGNITION ACC./OFF/ON/START

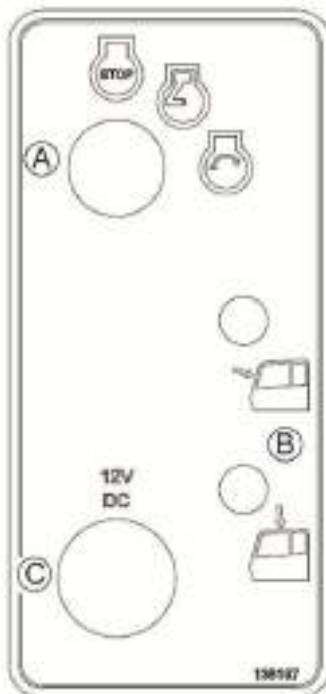

Ignition Acc/Off/On/Start

Start Switch **A**

This key-operated rotary switch controls starting and stopping of the engine. See engine operation section, for starting and stopping instructions.

Windshield Wiper & Washer Controls **B**

The rotary switch selects low or high speed operation of the windshield wiper or turns it off. Additionally there is a wiper located on the top roof glass. Pressing the switch for the front windshield will squirt fluid on it.

12V Outlet **C**

This 12V outlet is available to the operator for usage of cell phone charger, PC charger, etc.

OPERATING INSTRUCTIONS

3.10 FOOT THROTTLE

Reference Figure below. A

This pedal controls engine speed; pushing the pedal down increases speed, releasing it decreases speed.

The foot throttle pedal controls the engine speed when not in auto-idle mode (switch is red). Pushing the pedal down increases speed and releasing decreases speed. When in auto-idle mode, the foot throttle pedal does not affect engine speed.



Foot Throttle

OPERATING INSTRUCTIONS

3.11 SWING RIGHT/LEFT CONTROLS (LH JOYSTICK)

Reference Figure below.

NOTE

◆Speed of operation of the swing system is directly proportional to engine speed and control lever displacement.

Swing Control/Horn Button ^(A)

This lever controls the boom swing function. Moving the joystick left swings the upper structure left, and moving the joystick right swings the upper structure right. The trigger button at the front of this joystick sounds the warning horn when depressed.

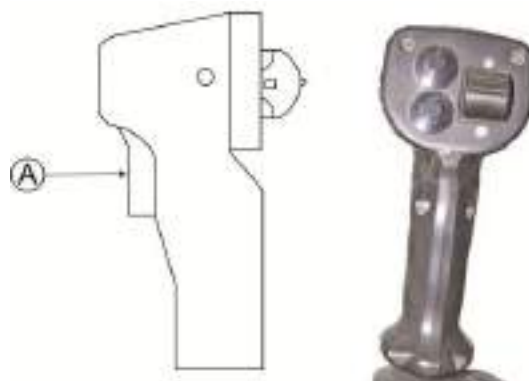

Swing Control & Horn Button

3.12 SWING BRAKE PEDAL

Reference Figure below. ^(B)

This pedal engages the swing brake when pushed forward (toe down) and releases it when the pedal is released.



Do not rest your foot on the swing brake pedal.



Swing Brake Pedal

OPERATING INSTRUCTIONS

3.13 SWING BRAKE SWITCH

Reference Figure below. ©

The switch engages and disengages the swing park brake and enables the swing function. When the switch is in the up position, the brake is engaged and swing is disabled. Flipping the switch down disengages the brake and enables swing.

It is recommended to apply the service brake (using the swing brake pedal) before releasing the park brake.

The brake will not disengage if the operator is not in the seat or the left armrest is raised. If the brake is disengaged and the operator stands up or raises the left armrest, the brake will engage. The brake will resume previous state when the operator sits again or lowers the left armrest.



Never engage the swing park brake when the swing is in motion.



Swing Brake Switch

OPERATING INSTRUCTIONS

3.14 TELESCOPE OUT/IN CONTROLS (LH JOYSTICK)

Reference Figure below.

Boom Telescope Control Lever ^(B)

The proportional slider switch on the left joystick operates the boom telescope function. Pushing the slider switch up causes the boom to extend and pushing it down causes the boom to retract.



Boom Telescope Control Lever

3.15 AUXILIARY WINCH CONTROL

Reference Figure below:

Auxiliary Winch Control Lever ^(C)

The left joystick controls the auxiliary winch control lever. Moving the joystick forward lowers the hook and pulling it back raises the hook.

Auxiliary Winch Speed Range Switch ^(D)

The bottom left button on the left joystick controls the auxiliary winch speed range. Pushing the button once switches from low to high speed. Pushing it again switches back to low speed. The current speed range is indicated on the display.

NOTE

◆ Winch line pull capacities are significantly reduced when operating in high speed.

Auxiliary Winch Rotation Indicator, “Thumb Thumper”

This crane is equipped with “thumb thumper” indicators for winch rotation. This joystick thumps whenever the auxiliary winch is rotating. Note that the thumper is in the handle.



OPERATING INSTRUCTIONS

Auxiliary Winch Disable

The auxiliary winch function may be disabled through the service page of the display. This is indicated on the display by a padlock next to the winch symbol.

3.16 MAIN WINCH/BOOM HOIST CONTROLS (RH JOYSTICK)

Reference Figure below:



Right Hand Joystick

NOTE

◆Speed of operation of the Winch and Boom Hoist Controls is directly proportional to engine speed and control lever displacement.

Main Winch/Auger Control

In standard mode, the right joystick controls the main winch. Moving the joystick forward lowers the hook block and pulling it backward raises the block.

Main Winch Speed Range

The button on the left joystick controls the main winch speed range. Pushing the button once switches from low to high speed. Pushing it again switches back to low speed. The current speed range is indicated on the display.

NOTE

◆Winch line pull capacities are significantly reduced when operating in high speed.

Winch Rotation Indicator, “Thumb Thumper”

This crane is equipped with “Thumb Thumper” indicators for winch rotation. This joystick thumps whenever the main winch is rotating. Note that the thumper is in the handle.

Main Winch Disable

The main winch function may be disabled through the service page of the display. This is indicated on the display by a padlock next to the winch symbol.

Boom Hoist Raise/Lower Control

The right joystick controls the boom hoist function. Moving the lever left raises the boom and moving it right lowers the boom.

OPERATING INSTRUCTIONS

3.17 TRAVEL CONTROLS

Reference Figure below:

Left ① /Right ② Track Forward/Track Reverse Pedals

These pedals control the track motion. Pushing either right or left pedal forward (toe down) moves its track forward; pushing either pedal backward (heel down) moves its track backward. Note the definition of “right” and “left” in Section 1.2.2 of this manual.

Travel speed is proportional to engine speed and pedal displacement. Increase engine speed to at least 1600 rpm before counter-rotating or high speed travel to avoid stalling the engine.



Travel Controls

OPERATING INSTRUCTIONS

Speed High/Low Switch A

The pushbutton selects either high or low travel speed. When the button is red, speed range is low. Pushing the button switches to high speed range and the color changes to green. Pushing the button again returns to low speed range. Note that high speed travel is only available when the AML verifies hook load is less than 5,000 lbs (2,270 kg) and the boom length is less than 73 ft (22 m). If high speed travel is not available, the button will flash red as an indication. Increase engine speed to at least 1600 rpm before counter-rotating or high speed travel to avoid stalling the engine.

Travel Brake On/Off Switch B

This pushbutton enables and disables the travel function. When the button is red, travel is disabled. Pushing the button enables travel and the color changes to green. Pushing the button again disable travel. Travel cannot be enabled if the operator is not in the seat or the left armrest is raised. If the travel is enabled and the operator leaves the seat or raises the left armrest, travel will be disabled. The button must be pressed again to enable travel.



Operator cab orientation affects the operation of the travel functions. See Section 1.2.2.



Travel Switches

OPERATING INSTRUCTIONS

Tracks Extend/Retract Switch

Reference Figure below.

On a standard crane, the left switch operates both the left and right track extend/retract function. The right switch is not present or functional. On a crane with optional carbody jacks, the left switch controls the left track and the right switch controls the right track.

Pushing and holding the front part of the switch causes the respective track(s) to extend and pushing and holding the back part causes the respective track(s) to retract. When in neutral, the switch color is red. When the switch is pushed and the output is activated, the color turns green.



Never lift loads with the 10010MX unless the tracks are fully extended (unless specifically allowed by a “tracks retracted load chart”).



The operator must ensure that no personnel are near the 10010MX's tracks before engaging the tracks extend function.



Tracks Extend/Retract Switch

OPERATING INSTRUCTIONS

3.18 AUXILIARY EQUIPMENT CONTROLS

Reference Figure below.

Tool Circuit Switch ①

This switch controls the tool circuit. When tool circuit is off, the switch is red. Pushing the front part of the switch turns high flow (10 gpm, 38 lpm) on to the optional tool connection ports, and the color changes to green. Pushing it again turns it off. Pushing the rear part of the switch turns it off. Pushing the rear part of the switch turns on low flow (5 gpm, 19 lpm), and the color changes to green. Pushing it again turns it off. It is also possible to switch between high and low flow without turning it off.

Auger Mode

If crane is equipped with optional auger, auger is enabled by changing to auger mode on the display. In auger mode, the right joystick controls the auger instead of the main winch.

Auger Latch Open/Closed Switch (Option) ②

This momentary push button disengages the latch that holds the auger in the stowed position. When the button is red, the auger latch is engaged. Pushing and holding the button disengages the auger latch, and the color changes to green. Releasing the button engages the latch again.



Auxiliary Equipment Controls

OPERATING INSTRUCTIONS

Go Lights

Reference Figure below.

Motorized lights are capable of 370° rotation and 135° degrees vertical tilt as needed for positioning. The controls are located on the right hand side of the cab and individually switched and controlled.



Go Lights

OPERATING INSTRUCTIONS

3.19 OTHER OPERATOR CONTROLS

Circulating Fan Hi/Med/Low Switch ①

(Reference Figure below) - This rotary switch selects high, medium, or low speed operation of the circulating fan motor or turns it off.

Heater/Off/AC Switch ②

(Reference Figure below) - This rotary switch selects heat, off or air conditioning operation. There are two water control valves mounted on the engine block that must be turned off/on to restrict or allow hot water to flow through the cab heater. If the A/C is on, the water flow to the heater should be turned off to achieve maximum cooling. If cab heat is desired the water flow to the heater should be turned on to achieve maximum heat.

Temperature Switch ③

(Reference Figure below) - This rotary switch is used for both the heat and air conditioning modes of operation. Turning to the "cool" position will cool down the cab in the A/C mode, whereas the "hot" position will heat the cab in the heat mode.



Fan/Heater/Air/Temp Controls

3.20 EMERGENCY BACK UP SYSTEM

In the event of system electrical or CAN BUS failure, some or all functions may be inoperable. If this occurs and it is necessary to operate the crane before the failure can be repaired, it is possible to bypass the normal control system and operate one or two functions at a time at reduced speed.



The operator is responsible for ensuring safe operation when using the emergency backup system as all normal interlocks are bypassed, including but not limited to the following: seat and armrest switch, AML & A2B, and winch last wrap indication.

3.20.1 Emergency Back Up System Procedure

1. Identify function(s) at the bulkhead plate to be operated and remove existing connector from outboard side.
2. Connect the "Y" connector harness stored next to the plate to the pendant connector.
3. Connect the "A" and/or "B" connector to the "Y" harness to the function connector(s) at the bulkhead plate.
4. Route the pendant cable through the rear cab window and sit in the operator seat.
5. Move the POWER switch to the "on" position and verify LED is "on."
6. Move the "A" and/or "B" direction switch in the required direction.

OPERATING INSTRUCTIONS

- a. Positive direction “+” is up, forward, right
 - b. Negative direction “-“ is down, reverse, left
7. Move the proportional trigger to start movement and control speed.
 8. For swing, the park brake must be released by holding the momentary brake release switch in the top left.
 9. After crane is in desired position, turn power off, disconnect “Y” harness at bulkhead plate, and reconnect normal harness.



Emergency Back Up Bulkhead



Emergency Back Up Pendant

3.21 BATTERY CUTOFF SWITCH

This switch (A), located in the battery compartment, selects the connection between the 10010MX's batteries and electrical system. The operator may connect or disconnect either or both batteries.

For normal operation, both batteries should be connected.

Whenever the crane is left unattended, the operator should turn this switch to off and lock the covers to prevent tampering with the crane.

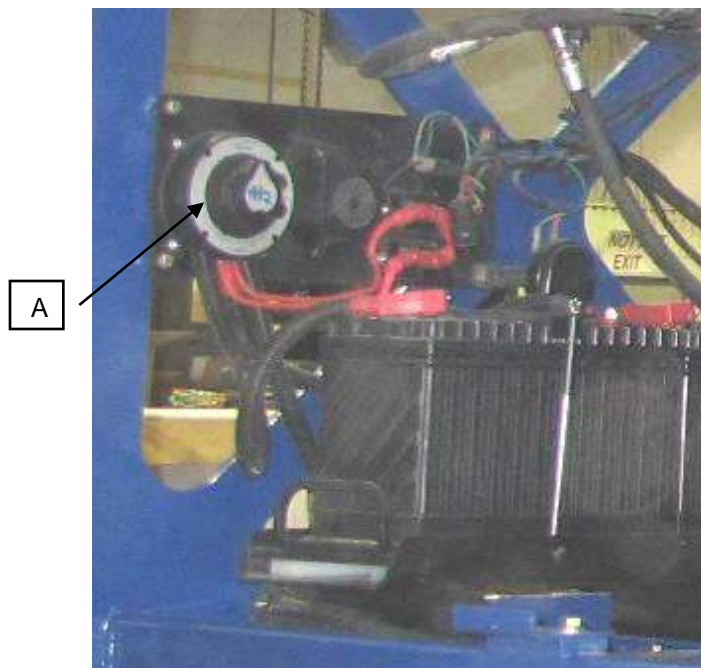

OPERATING INSTRUCTIONS

3.22 OPERATION

3.22.1 Alarm Systems

The Tadano Mantis 10010MX uses the Cummins QSB 6.7 diesel engine with an integral hydraulic pump to provide power for all machine functions. The 10010MX incorporates a number of alarm systems to protect the engine from abnormal operating conditions.

These alarm systems provide a visual warning to signal the operator that an abnormal operating condition exists. Alarms are triggered by low oil pressure or high coolant temperature. Each alarm will continue until the cause of the alarm condition is corrected.

See section 4 (dash/control panels) for a description of the 10010MX engine alarms.

3.22.2 Walk-Around Inspection

For maximum service life of your engine, make a thorough inspection before starting the engine. Look for such items as oil or coolant leaks, loose fasteners, worn fan belts, and trash build-up. Remove trash build-up and have repairs made as needed. Perform required periodic maintenance before starting the engine. Make a walk-around inspection of the equipment. A few minutes spent making minor corrections can prevent major repairs later. Wipe fittings, caps, and plugs clean before servicing.



Accumulated grease and oil on an engine or platform is a fire hazard. Remove this debris with steam cleaning or high pressure water at least monthly or whenever any significant quantity of oil (or other fluid) is spilled on or near an engine and working area.

3.22.3 Air Intake System

- Observe the air filter clogging warning and service the air cleaner when the light comes on.
- Inspect the air intake system hoses, piping, elbows and gaskets for cracks or damage. Replace items as needed. Check for loose clamps and tighten if necessary.

3.22.4 Engine Cooling System

- Inspect the cooling system for leaks and trash build-up. Clean any accumulation with compressed air or high-pressure water.
- Inspect the water pump for leaks.

NOTE

◆The water pump seal is lubricated by the engine coolant. A small amount of leakage as the engine cools down and parts contract is acceptable.

- Inspect the system hoses and crankcase breather hose for cracks and loose clamps.
- Inspect the fan and accessory drive belts for cracks, breaks, or other damage. Check for proper belt tension.
- For additional cooling system information, refer to Section 4.

OPERATING INSTRUCTIONS

3.22.5 Electrical System

Wiring must be kept in good condition, properly routed and firmly attached. Routinely inspect wiring for wear or deterioration. Loose connectors or dangling wiring must be tightened or reattached. Do not bypass fuses.

Tight connections and properly maintained cables will help prevent sparking that could cause a fire.

- Inspect the engine-to-frame rail ground strap for good connection and condition.
- Check the battery and battery cables for poor connections and corrosion.

3.22.6 Fuel and Lube Systems

- Make sure fuel lines are properly clamped and tight. Check for loose fittings or leaks.
- Drain water from the water separator.
- Check for lubrication leaks at areas such as the front and rear crankshaft seals, crankcase, oil filter, oil gallery plugs, sensors, and valve covers.

NOTE

◆ If you observe leaking fluid, find the source and correct the leak. If you suspect a fluid leak, check the fluid levels more frequently than the recommended service intervals until you either find a leak or prove to your satisfaction that there is no leak.

3.23 PRE-START CHECKS

- All guards must be in place. Repair or replace all guards that are damaged or missing.
- Measure the engine crankcase oil level. The correct oil level is between the high (H) and low (L) marks on the dipstick. Oil capacity from the low to high marks is 1.9L (2 qt.).
- Check the oil level(s) on driven equipment.

NOTE

◆ Make sure the crane is level when checking the engine oil level.

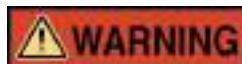

- ❖ **Diesel engine exhaust contains products of combustion that may be harmful to your health. Always start and operate the engine in a well-ventilated area, and, if in an enclosed space, vent the exhaust to the outside.**
- ❖ **Do not start the engine or move any of the controls if there is a “do not operate” or similar warning tag attached to the start switch or controls.**

Make sure no one will be endangered before starting the engine. If the engine has not been run for several weeks, fuel may have drained and allowed air into the filter housing. Also, when fuel filters have been changed, some air space will be left in the housing. In these instances, prime the fuel system.

OPERATING INSTRUCTIONS



- ❖ Do not engage the starter when the engine is turning. Do not start the engine under load.
- ❖ For starting below -18°C , use of optional cold weather starting aids is recommended. A coolant heater or extra battery capacity may be required.
- ❖ For temperature below -23°C , consult your local diesel engine dealer.

3.24 ELECTRIC STARTING

NOTE

◆ Starting ability will be improved at temperatures below -18°C by the use of a starting aid and/or use of a jacket water (coolant) heater or other means to heat the cylinder block.

Start the engine using the following procedure:

1. Make sure that all hydraulic control levers are in their neutral positions.
2. Turn the starter switch to the “start” position. Crank the engine. Release the switch as soon as the engine starts.



- ❖ Do not crank the engine for more than 30 seconds. Allow the starter to cool for two minutes before cranking again.
 - ❖ Turbocharger damage can result if the engine rpm is not kept low until the engine oil light or gauge verifies the oil pressure is sufficient.
 - ❖ Consult the engine operating manual for complete details on proper operating speeds.
 - ❖ Additional injections of ether may also be required to achieve a low idle speed.
3. If the engine fails to start within thirty seconds, release the starter switch and wait two minutes to allow the starter motor to cool before using it again.
 4. Once the engine starts, allow it to run at low idle speed for three to five minutes, or until the engine temperature gauge indicator has begun to rise. Increase engine speed to high idle only after the engine is running smoothly at low idle.
 5. Allow the white smoke to clear up and proceed with normal operation. Do not apply load to the engine or increase engine speed until the oil pressure gauge indicates normal. Oil pressure should rise within fifteen seconds after the engine starts.



If oil pressure does not rise within fifteen seconds after the engine starts, stop the engine and follow necessary troubleshooting procedures before restarting.

6. Operate the engine at low load and rpm until the engine temperature is within its normal range. Monitor all gauge readings during this warm-up period.

OPERATING INSTRUCTIONS

3.24.1 Starting With Jumper Cables



- ❖ Batteries give off flammable fumes that can explode.
- ❖ Improper jumper cable connections can cause an explosion resulting in personal injury.
- ❖ Prevent sparks near the batteries. Sparks could cause vapors to explode. Do not allow jumper cable ends to contact each other or the engine.
- ❖ Do not smoke when observing the battery electrolyte levels.
- ❖ Always wear protective glasses when working with batteries.
- ❖ Electrolyte is an acid and can cause personal injury if it contacts skin or eyes.
- ❖ Engines installed without separate engine-to-frame rail ground straps can be damaged by electrical discharge.
- ❖ To prevent electrical discharge damage, check to make sure the engine's electrical system has a separate engine-to-frame rail ground strap. For engines which have the alternator connected to an engine component, the ground strap must connect that component to the frame.
- ❖ Some engines have starter-to-frame ground straps, but many of these starters are not electrically grounded to the engine. They have electrical insulation systems.
- ❖ For this reason, the starter-to-frame ground strap may not be an acceptable engine ground.
- ❖ When boost starting, refer to the instructions that follow to properly start the engine.

NOTE

◆When using an external electrical source to start your engine, turn the start switch off and turn off all electrical accessories before attaching cables.

Your engine may be equipped with a 12- or 24-volt starting system. Use only the same voltage for boost starting. Use of a welder or higher voltage will damage the electrical system.

When using jumper cables, always connect positive (+) cable to positive (+) battery terminal, which is connected to starter solenoid, and negative (-) cable from external source to starter negative (-) terminal. If not equipped with a starter negative terminal, connect to the engine block.

Do not reverse the battery cables. The alternator can be damaged.

1. Attach the ground cable last and remove it first.
2. Connect one end of the cable to the positive (+) terminal of the battery being started. Connect the other end to the positive (+) terminal of the power source.
3. Connect one end of the other cable to the negative (-) terminal of the power source. Connect the other end to the starter negative (-) terminal or to the engine block. This prevents potential sparks from igniting combustible gases produced by some batteries.

OPERATING INSTRUCTIONS

4. Begin cranking engine to start and achieve idle speed.
5. After the engine starts, disconnect the cable from the starter negative (-) terminal or engine block. Disconnect the other end from the negative (-) terminal of the power source.
6. Disconnect the cable from the positive (+) terminal of the battery on the engine being started. Disconnect the cable from the positive (+) terminal of the power source.

3.24.2 After Starting the Engine

As soon as the engine starts, release the starter switch and reduce rpm to low idle.



Keep engine speed low until the engine oil pressure registers on the gauge or the engine oil light goes out. If the gauge does not register or the light does not go out within fifteen seconds, stop the engine and investigate the cause before starting again. Failure to do so can cause engine damage.

1. Allow a cold engine to warm up at low idle for at least five minutes. Do not apply load to the engine or increase engine rpm until the oil pressure gauge indicates normal.
2. When idling the engine for warm up, observe the following recommendations:
 - In temperatures above 0°C, warm-up requires approximately fifteen minutes.
 - In temperatures below 0°C, warm-up requires approximately thirty minutes or more.
 - In temperatures below -18°C, warm-up requires more than thirty minutes.
3. Operate the engine at low load and rpm until the engine temperature reaches its normal operating range. Check all gauges during the warm-up period.
4. After the engine is started and the cold idle operation is completed, the engine can be operated at low speed and low power. The engine will reach normal operating temperature faster when operated at low speed and low power demand than when idled at no load.
5. Maximum no-load speed for a warm engine is 2200 rpm. Exceeding this limit may cause severe engine damage.

NOTE

◆ At lower engine speeds, there may not be enough flow to operate multiple functions. To operate multiple functions simultaneously, increase engine speed.

6. Check all gauges and warning lights frequently during operation.

3.24.3 Engine Stopping



Stopping the engine immediately after it has been working under load can result in overheating and accelerated wear of the engine components. Follow the stopping procedure outlined below to allow the engine to cool. Excessive temperatures in the turbocharger center housing could cause oil coking problems.

Make sure that you understand the engine stopping procedure before operating the engine.

OPERATING INSTRUCTIONS

Manual Stop Procedure:

1. Reduce engine speed to low idle.
2. Remove load from engine by ceasing all hydraulic-powered operations.
3. Increase engine speed to no more than half full load (rpm) speed for two minutes to cool the engine.
4. Reduce engine speed to low idle for five minutes to cool the engine and prevent oil coking problems in the turbocharger center housing.
5. Stop the engine by turning the ignition switch to “off.”

3.24.4 After Stopping the Engine

1. After the engine cools, fill the fuel tank to prevent accumulation of moisture in the fuel.
2. Water-cooled engines only:
3. Maintain the cooling fluid levels to ½ in (13 mm) from bottom of the fill pipe.
4. If you expect freezing temperatures, allow the engine jacket water cooling system to cool, and then check the coolant for proper antifreeze protection. The system must be protected against freezing to the lowest expected outside temperature.
5. Add a coolant mix of antifreeze and water.
6. Check the engine crankcase oil level. The correct oil level is between the high (H) and low (L) marks on the dipstick. Oil capacity from the low to high marks is 1.9 L (2 qt.).

NOTE

◆ Make sure the crane is level when checking the engine oil level.

7. Always wait at least five minutes after shutting off the engine before checking the oil level to allow oil to drain back into the oil pan.
8. Repair any leaks, perform minor adjustments, tighten loose bolts, etc.
9. Observe the service meter reading. Perform periodic maintenance as indicated in the maintenance chart.
10. If the crane will be left unattended for an extended period of time (e.g. overnight or over a weekend), turn off and lock the battery cutoff switch. This will help prevent unauthorized use of the crane and/or accidental battery discharge.

3.24.5 Horn

A horn button is located on the front of the left hand joystick for alerting anyone in the vicinity of the crane. This horn button is always powered and should be used to sound alert prior to starting the crane engine.

OPERATING INSTRUCTIONS

3.25 COLD WEATHER OPERATION

Diesel engines can operate effectively in cold weather. Engine operation in cold weather, however, is dependent on the type of fuel used and how well the fuel moves through the fuel-related components. The purpose of this section is to explain some of the problems and steps that can be taken to minimize fuel problems during cold weather operation when the engine area is colder than 5° C.

3.25.1 Fuel Selection

During cold weather operation, you may need to use No. 2 diesel fuel since quantities of No. 1 diesel fuel are limited and generally are only available during the winter months and in the colder climates.

The two major differences between No. 1 and No. 2 diesel are No. 1 diesel has a lower cloud point and a lower pour point.

The **cloud point** is the temperature at which a cloud or haze of wax crystals begins to form in the fuel and cause fuel filters to plug. The **pour point** is the temperature at which diesel fuel begins to thicken and becomes more resistant to flow through fuel pumps and lines.

Be aware of these fuel values when purchasing your diesel fuel and anticipate the average outside (ambient) temperature for the area where your Tadano Mantis crane will be operating. Engines fueled in one climate may not operate satisfactorily if moved to another because of problems that result from cold weather.

NOTE

◆The average No. 1 diesel fuel has a lower heat content (kJ or BTU) rating per unit volume of fuel than the average No. 2 diesel fuel. When using No. 1 diesel fuel, you may notice a drop in power and fuel efficiency, but you should not experience any other operating effects.

Before troubleshooting for low power or poor performance in winter months, check the type of fuel you are using.

The use of starting aids, engine oil pan heaters, coolant heaters, fuel heaters, and fuel line insulation also provide some means of minimizing starting and fuel problems in cold weather when No. 2 fuel is used.

3.25.2 Fuel Heaters

Fuel heaters prevent plugging of the fuel filters due to waxing in cold weather. Tadano Mantis cranes intended for use in cold climates are equipped with suitable fuel heaters and control circuitry. See the Maintenance Manual for your crane for details.

Make sure that the fuel heater is deactivated in warm weather. A loss of engine power can occur if the fuel supply temperature exceeds 30°C.

3.25.3 Fuel Filters

Tadano Mantis diesel-powered cranes are equipped with a water separator between the fuel tank and the engine-mounted fuel filter. The micron rating and location of the water separator are chosen for proper operation in cold weather. The water separator and its fuel supply line are the components most commonly affected by cold fuel.

3.25.4 Engine Compartment Temperature

Maintaining as high a temperature as possible in the engine compartment can be very helpful in avoiding cold weather problems in your Tadano Mantis crane.

Always keep all engine covers and access panels closed in cold weather to retain as much engine heat as possible.

Depending on the options you specified, your crane may have a radiator shutter, winter front, and/or thermostatically controlled (clutch-type) fan to minimize warm-up times.

At coolant temperatures below 160°F (71°C) the clutch fan should be off; at temperatures 205°F (96°C) the fan should operate. If your engine will not maintain proper operating temperature, check the fan for proper operation.

OPERATING INSTRUCTIONS

3.26 WINCH OPERATION

3.26.1 Main Winch

The joystick mounted in the right hand console controls the main winch raise/lower function.

To raise a load, the joystick is pulled rearward; to lower a load, the joystick is pushed forward. As with all other functions, speed is directly proportional to engine speed and control displacement.

Main Winch Speed Range:

The button on the right joystick controls the main winch speed range. Pushing the button once, switches from low to high speed. Pushing the button again switches back to low speed. The current speed range is indicated on the display. The winch may be shifted from high to low or from low to high at any time during operation.

3.26.2 Auxiliary Winch

The joystick mounted in the left hand console controls the aux winch raise/lower function.

To raise a load, the joystick is pulled rearward; to lower a load, the joystick is pushed forward. As with all other functions, speed is directly proportional to engine speed and control displacement.

Auxiliary Winch Speed Range:

The bottom left button on the left joystick controls the auxiliary winch speed range. Pushing the button once switches from low to high speed. Pushing the button again switches back to low speed. The current speed range is indicated on the display. The winch may be shifted from high to low or from low to high at any time during operation.

3.26.3 Winch Warm-Up Procedure

Performing a warm-up procedure is recommended at each startup and is essential at ambient temperatures below 4°C.

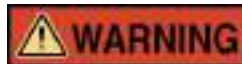

Failure to properly warm up the winch, particularly in low temperatures may result in temporary brake slippage. Such operation will create a hazardous situation that may result in serious injury, death and/or equipment damage.

To properly warm up the winch, run the 10010MX diesel engine at its minimum recommended rpm with the hydraulic winch control lever in its neutral position.

Once the engine has reached operating temperature, operate the winch with no load at low speeds, forward and reverse, several times to prime all lines with warm hydraulic oil and to circulate gear lubricant through the planetary gear sets.

3.26.4 Anti-Two-Block Control

The winch functions employ an A2B operator aid to prevent a “two-block” situation. When the hook block or overhaul ball trips the anti-two block switch or a RCI/A2B system error, the microcontroller will disable the main and auxiliary winch function in the raise direction. The A2B override switch located in the right console is available for rigging and set up.



When the override switch is used, the winch will not stop, even in an overwind condition.

OPERATING INSTRUCTIONS

3.26.5 Overload Control

The winch functions employ a RCI/Overload operator aid to prevent an overload condition. When the actual load is 100% or more of the rated load or a RCI system error occurs, the microcontroller will disable the main and auxiliary winch function in the raise direction. The overload override switch located in the right console may be used to stow the boom in the event of a RCI system error.



Pushing the override switch cancels the stop function of the RCI and crane control system. Using this switch during normal operation is extremely dangerous. Do not use this switch during normal operation. Use the switch only when operation has been disabled due to failure of the RCI system.

3.26.6 Last Wrap Control

The winch functions employ a last wrap operator aid to maintain a minimum amount of rope on the drum. When the last wrap is reached on the main or auxiliary winch, the microcontroller will disable the respective winch function in the lower direction. If the rope is removed, replaced, fully wound on the drum, or any time the winch is operated when the rope is not reeved, the last wrap indicator must be reset. The last wrap override switch on the right console may be used to allow removal of the rope from the winch.



If the last wrap indicator is not properly set, there will not be a warning when the limit is approached, and the function will not be blocked when the limit is reached. The operator is responsible for verifying the warning and shutdown are working properly. Failure to comply may result in serious injury, death, and/or equipment damage.



When the override switch is used, the winch will not stop, even in an underwind condition.

OPERATING INSTRUCTIONS

3.27 BOOM CONTROLS

3.27.1 Boom Hoist

The joystick mounted in right hand console controls the boom up/down function. This function consists of a manifold-mounted directional control valve, which is connected to a single double-acting cylinder. The cylinder is fitted with an integral counterbalance valve that holds the cylinder in the extended position until pressure is applied to the retract port, unlocking the valve and allowing the cylinder to lower the boom. To raise the boom, the joystick is moved left, to lower the boom the joystick is moved right. As with all functions, the speed is directly proportional to engine speed and control displacement.

3.27.2 Boom Telescope

The boom telescope function is controlled by the telescope out/in proportional slider switch located in the left joystick. The four-stage boom is operated by a combination of hydraulic cylinders, cables, and sheaves. The second stage will extend to its maximum position before the third and fourth stages start to extend. As further hydraulic pressure is applied, the third and fourth stages will begin to extend proportionally. Conversely, when retracting the boom, the third and fourth stages will retract proportionally and fully prior to the second stage retraction. The boom telescope cylinder is equipped with an integral counterbalance valve that hold the boom in the extended position until pressure is applied to the retract port, unlocking the counterbalance valve and allowing the cylinder to retract. As with all other functions, retract boom telescope speed is directly proportional to engine speed and control displacement.

3.27.3 Anti-Two-Block (A2B) Control

The boom functions employ an A2B operator aid to prevent a “two-block” situation. When the hook block or overhaul ball trips the anti-two block switch or a RCI/A2B system error, the microcontroller will disable the boom function in the down direction and the boom telescope function in the extend direction. The A2B override switch located in the right console is available for rigging and setup.



When the override switch is used the boom will not stop, even in an overwind condition.

3.27.4 Overload Control

The boom functions employ a RCI/Overload operator aid to prevent an overload condition. When the actual load is 100% or more of the rated load or a RCI system error occurs, the microcontroller will disable the boom function in the down direction and the boom telescope function in the extend direction. The overload override switch located in the right console may be used to stow the boom in the event of a RCI system error.



Pushing the override switch cancels the stop function of the RCI and crane control system. Using this switch during normal operation is extremely dangerous. Do not use this switch during normal operation. Use the switch only when operation has been disabled due to failure of the RCI system.

3.27.5 Backward Stability Control

The boom functions employ a backward stability operator aid. In the event of a backward stability condition or a RCI system error occurs, the microcontroller will disable the boom function in the up direction and the boom telescope

OPERATING INSTRUCTIONS

function in the retract direction. The overload override switch located in the right console may be used to stow the boom in the event of a RCI system error.



Pushing the override switch cancels the stop function of the RCI and crane control system. Using this switch during normal operation is extremely dangerous. Do not use this switch during normal operation. Use the switch only when operation has been disabled due to failure of the RCI system.

3.27.6 Swing Controls

The swing function is controlled by the left joystick. The swing system consists of a directional control valve, dual mode swing valve, hydraulic motor, a spring applied/hydraulically-released park brake with an integral spring-released hydraulically-applied service brake, and a gear reducer mounted to the upper structure of the crane. The console-mounted control lever controls the directional control valve, which routes pump flow to the swing motor, which through the brake, causes the reducer to turn the shaft-mounted pinion gear, meshed with the slew ring and upper structure. To swing left, the control lever is moved left; to swing right, and the lever is moved right. As with all functions of the crane, speed is directly proportional to engine speed and control lever displacement.

3.27.7 Dual Mode Swing Valve

The swing mode is controlled by the soft key on the display. In free swing mode, when both swing park brakes are released, the upper structure is free to move based on gravity or inertia. When not in free swing mode, the upper structure is hydraulically held in position by counterbalance valves, unless the swing function is activated by the joystick.

3.27.8 Swing Park Brake

The park brake is controlled by the swing park brake on/off switch. The park brake is used to hold the upper structure in position for extended periods of time.



Never use the park brake to stop the swing motion of the upper structure under any circumstances.

3.27.9 Swing Service Brake

The service brake is controlled by the floor-mounted foot pedal (far left) and is used to slow and stop the swing motion of the crane upper structure.

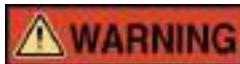

Never rest your foot on the swing brake pedal during swing operation; even slight pressure will cause excessive wear on the swing brake mechanism.

OPERATING INSTRUCTIONS

3.28 TRAVEL CONTROLS

3.28.1 Tracks Forward/Reverse

In **Standard Mode** the travel function is controlled by two floor mounted foot pedals, which provide a CAN BUS signal to the microcontroller which in turns provides an output to the manifold-mounted directional valves. In the forward direction (boom over the idler end) the left pedal controls the left track and right pedal controls the right track.

Pushing the pedal(s) toe-down, moves the crane forward. For reverse travel, push the pedals heel down, which will move the crane backward. The speed of travel, as with all other functions, is directly proportional to engine speed and control displacement.

In **Travel Mode**, the travel function is controlled by the right joystick. Moving the lever forward moves the cranes forward and moving it backward moves the crane back. Counter-rotation is achieved by moving the joystick left or right, depending on the desired direction.

To skid steer, the joystick is moved to an intermediate position (i.e. to the corner).

The travel brake on/off pushbutton switch disables the travel pedals. The travel brake switch must be set off before travel can be initiated. Also connected to the travel brake switch is the motion alarm, which is sounded any time travel brake switch is turned off. This alarm will alert all personnel that travel can occur at any time. The track drive motors are two-speed and are shifted by pilot pressure through a solenoid valve controlled by a dash-mounted pushbutton switch marked travel speed high/low.



DO NOT shift between travel speeds while the crane is in motion.

Maximum effort is realized with the motors in low speed, the engine at top speed, and maximum pedal displacement.

3.28.2 Tracks Extend/Retract

The 10010MX track extend/retract function powers the crawler frames in or out. Independent right and left track frame extension/retraction functions are actuated by the dash-mounted tracks (extend/retract rocker switches). The carbody directional control valve is fitted with integral cross-flow check valves to prevent the cylinders from drifting in or out unless pressure is applied.



- ❖ **NEVER operate the crane without first fully extending the crawler frames.***
- ❖ **Attempting to lift loads with the crawler frames retracted would very likely cause overturning, which will result in serious injury, death and/or equipment damage.***

*Unless operations are within parameters specifically allowed by the "tracks retracted load chart" for this model.

OPERATING INSTRUCTIONS

3.29 AUGER OPERATION (OPTIONAL)

The Mantis 10010MX may be equipped with an optional auger. The auger is controlled by:

- a) The system control display, which is used to enable the auger and switch the joystick to auger mode
- b) The RH joystick (the main winch is not used in this mode, instead the joystick controls auger direction and speed by pushing forward or pulling back)
- c) A switch on the RH side control panel, which opens the auger latch

3.29.1 Digging with the Auger

The optional auger circuit utilizes the winch control level to control the direction and speed of auger rotation. The operator selects auger operation by enabling the auger mode on the system control display. Use the following steps to prepare the auger for digging:

1. Set the crane mode to “auger” on the display and remove the safety pin from the auger storage latch.
2. Slowly push the winch/auger control joystick forward to be sure the wind-up cable is supporting the auger.
3. Open the latch by pressing the auger latch open/close switch.
4. With the latch open, slowly pull the control lever rearward to lower the auger out of the latch until the wind-up cable swings clear. Releasing the auger latch open/close switch will automatically close the latch.

With auger in digging position, push the winch control lever forward to dig and pull it rearward for reverse. As with all other functions, auger rotation speed is directly proportional to engine speed and control lever displacement.

Lower the auger into the earth by pushing the boom hoist joystick right; raise the auger by pushing the joystick left. The operator must determine proper digging and lowering rates depending on soil conditions.

3.29.2 Stowing the Auger

When digging is complete, return the auger to the stowed position in the storage latch using the following steps:

1. Attach the wind-up cable to the auger shaft.
2. Push the winch/auger control joystick forward to draw the auger into the latch.
3. After the auger shaft contacts the torque limiting valve and the motor stops rotating, the latch will open automatically when the shaft hits it. Install the safety pin. Next pull the control lever rearward, lowering the auger shaft to the latch plunger.

When not in use, the auger may be left in the digging position with the auger mode off, if desired, to prevent spending excessive time in storing and rigging the auger.



Do not use the boom hoist function to force the auger into the ground. The boom is not designed for large upward loads, therefore damage to the machine, or bodily injury could occur.

3.29.3 Tool Circuit Operation

The crane may be equipped with the optional tool circuit for operating hydraulic impact wrenches, tampers, etc. The tool circuit is designed to deliver either 5 gpm (19 lpm) or 10 gpm (38 lpm) @ 2500 psi (176 bar) to the reel-mounted hose at the front of the right side of the crane. Hoses on the reel are fitted with quick-disconnect couplings to attach the desired tool. The tool circuit is activated by the dash-mounted tool high/ off/low rocker switch.

OPERATING INSTRUCTIONS

3.30 REEVING

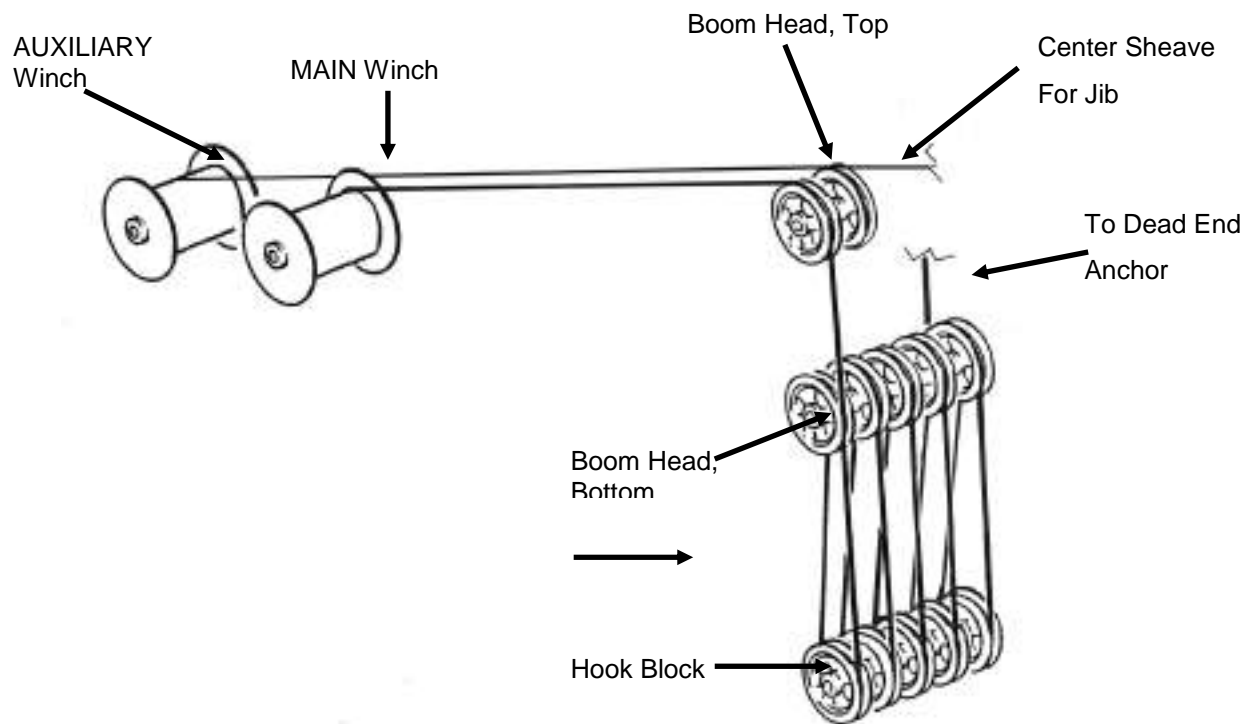

The reeving diagram below illustrates the correct reeving procedure.



The following table shows the standard parts of line. Select the number of parts of line that ensures the most efficient operation, taking into consideration boom length, radius, load mass, hoisting speed and other considerations such as winch drum wire rope capacity.

Number of parts of line	10	8	7	6
Reeving pattern				

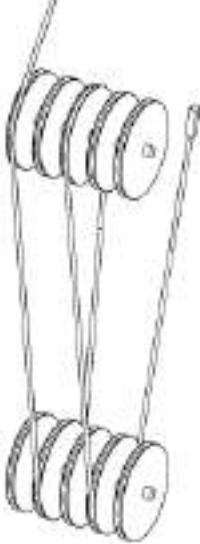
OPERATING INSTRUCTIONS

Number of parts of line	5	4	3
Reeving pattern			



DO NOT exceed the manufacturer's specified maximum reeving of 10 parts of line. 10-Part reeving is required for full capacity lifting.



When attaching the wedge socket to one of the internal boom structural members, do not configure the wire rope in such a way that it will hit the dead end pin at high boom angles. To avoid this situation, select a dead end position further away from the line falls.

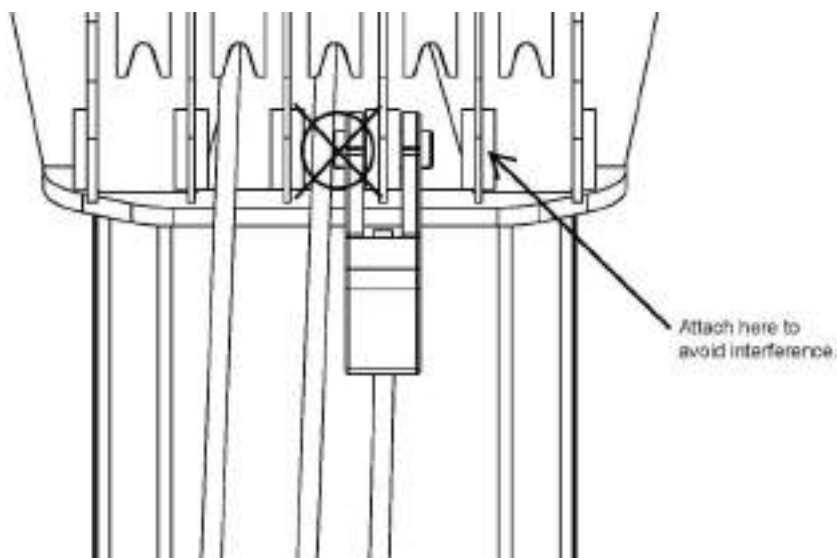

OPERATING INSTRUCTIONS

3.31 PREPARATION FOR SHIPPING

Due to the weight and overall width of the Tadano Mantis 10010MX cranes, it may be necessary to remove certain components from the machine for transport in your area. The procedures in the following sections will guide you through disassembly and reassembly of your crane if the need arises.



When installing or removing any component of a Tadano Mantis crane, use the same safety procedures that you use when making any other lift with the crane.

NOTE

◆ The disassembly and reassembly of crane components will be much easier if performed on a smooth, stable, level surface.

The easily-removed components are:

- Counterweight(s)
- Lattice jib and extension

Disassembly or reassembly of any of these parts of the crane will require a crane or other lifting machine of rated capacity to handle the components to be removed.

10010MX REMOVABLE COMPONENT WEIGHTS AND DIMENSIONS		
COMPONENT	Lb	kg
Counterweight	20000	9070

3.32 COUNTERWEIGHT REMOVAL/INSTALLATION

The counterweight of the 10010MX is installed or removed by using the crane's boom telescope out/in control with special counterweight handling rigging installed.



When installing or removing the counterweight, use the same safety procedures that you use when making any other lift with the crane.

NOTE

◆ Installing or removing the counterweight is much easier if the crane is on a level surface. If you cannot level the crane completely, select a position that levels it from side to side.

3.32.1 Installing the Counterweight

1. Set the counterweight on level ground behind the crane, directly below its installed position.
2. Install the counterweight handling sheave in the sheave bracket slot. The rear edge of the sheave should be directly above the counterweight lifting lug.
3. Lower the boom fully and attach one end of the counterweight handling pendant to the upper boomhead lug. Run the pendant cable over the sheave installed in step 2 and attach the free end to the counterweight lifting lug.
4. Raise the boom far enough so that the pendant cable clears both the main and auxiliary winches.

OPERATING INSTRUCTIONS

5. Using the boom telescope control, extend the boom until the counterweight support lugs align with the mounting lugs on the 10010MX.
6. Install the counterweight support pins; release the tension on the pendant cable by retracting the boom.
7. Lower the boom fully; detach the counterweight handling pendant from the counterweight and boomhead lugs.
8. Install the two bolts that secure the lower edge of the counterweight to the crane body.

3.32.2 Removing the Counterweight

1. Remove the two bolts that secure the lower edge of the counterweight to the crane body.
2. Install the counterweight handling sheave in the sheave bracket slot. The rear edge of the sheave should be directly above the counterweight lifting lug.
3. Lower the boom fully and attach one end of the counterweight handling pendant to the upper boomhead lug. Run the pendant cable over the sheave installed in step 2 and attach the free end to the counterweight lifting lug.
4. Raise the boom far enough so that the pendant cable clears both the main and auxiliary winches.
5. Using the boom telescope control, extend the boom until the pendant cable is taut and supports the counterweight. The counterweight support pins should now be bearing no weight.
6. Remove the counterweight support pins; lower the counterweight to the ground by retracting the boom.
7. Lower the boom fully; detach the counterweight handling pendant from the counterweight and boomhead lugs.

OPERATING INSTRUCTIONS

3.33 JIB/EXTENSION REMOVAL/INSTALLATION



When installing or removing the jib/extension, use the same safety procedures that you use when making any other lift with the crane.



- ❖ To prevent damage to the jib/extension when removing it from the main boom, always use nylon slings of rated capacity to handle the load.
- ❖ Sling only around the main chords of the jib and/or extension. Applying the sling to lattice work will damage the jib or extension.

See the figures for placement of slings to attain the best balance of components. It is advisable to have the jib and extension in the stowed position and remove both as a unit, since both components are supported by the storage brackets on the main boom.

LIFTING POINTS FOR JIB ALONE, EXTENSION ALONE, AND JIB & EXTENSION TOGETHER

CENTER LIFTING AROUND THE POINTS INDICATED

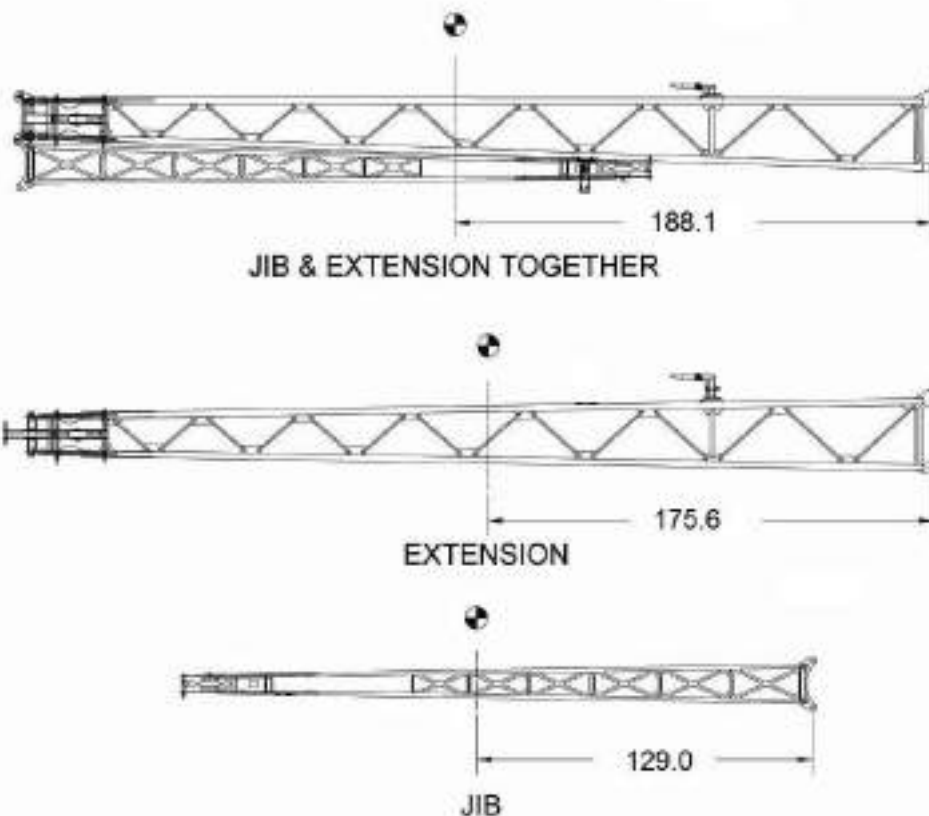

OPERATING INSTRUCTIONS

3.33.1 Removing the Jib and Extension

To remove the jib and extension as a unit, follow the steps outlined below.

1. Lower the main boom to a level position.
2. Attach slings at the locations shown in the figure. Attach tag lines to each end of the load.
3. "Snug up" on the slings to be sure the load is secure. Do not lift the load at this time. Check to be sure all rigging is secure.
4. Remove the pin from the extension storage bracket at the rear of the boom and remove the pins at the extension attachment to the main boom head.
5. Using the tag lines to maneuver the load, slowly lift the jib/extension off the support brackets and move it away from the main boom. Lower the jib/extension to the ground, clear of the work area, and set it on supporting blocking.



**DO NOT set the jib/extension directly on the ground;
damage to lattice work may occur.**

6. Store all attachment hardware in the crane storage box located under the hydraulic tank.

3.33.2 Installing the Jib and Extension

To install the jib and extension as a unit, follow the steps outlined below.

1. Lower the main boom to a level position.
2. Attach slings to the jib/extension at the locations shown in the figure. Attach tag lines to both ends of the load.
3. Using the tag lines to maneuver the load, slowly lift the jib/extension off the supporting blocking and move it toward the main boom.
4. Align the attachment lugs on the extension with the corresponding lugs on the boom head. Install the pins through the attachment lugs and secure them.
5. Install and tighten the nut at the extension tip sheave location storage bracket
6. Release tension on the lifting slings and disconnect them from the extension.

OPERATING INSTRUCTIONS

3.34 EXTENSION/JIB ERECTION & RIGGING

The 10010MX crane may be equipped with the optional 9.1m (30 ft) lattice extension and 6.1m (20 ft) lattice jib. The extension may be used alone or with the jib. The jib is used only with the extension.

When the extension is used alone, it is rigged either 1-part with an overhaul ball or 2-part with a hook block. When the extension and jib are used together, rigging is 1-part with an overhaul ball. The extension and jib are stowed alongside the main boom when not in use.

NOTE

◆ All left and right directional references are as viewed from the crane operator's seat.



Parts of this procedure require the use of the crane's power. Never activate any of the crane's control while personnel are in contact with any part of the boom, extension, or jib.



- ❖ Crane should be on firm and level ground before erecting and/or rigging the extensions and/or jib.
- ❖ Make sure the area around the crane is free of objects that may obstruct the path of the extension and/or jib during mounting or stowing.

3.34.1 Erecting and Rigging the Extension

Follow the steps below to erect the extension alone from its stowed position. See the figures below and on the following pages for location of the details mentioned in this procedure.

NOTE

◆ When rigging with the 30 ft extension alone, the jib must be completely removed from the extension assembly and set safely aside.

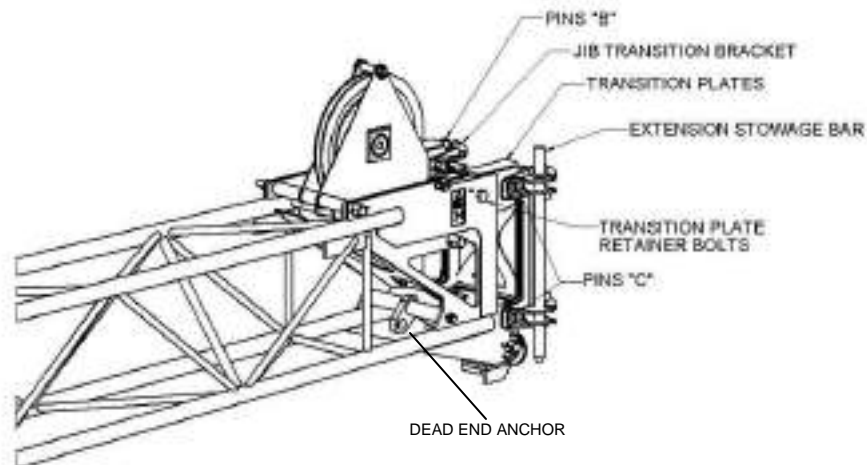

OPERATING INSTRUCTIONS

1. Retract the boom fully and lower it to a horizontal position.
2. The two far right pin bosses on the boom head should be aligned with the pin bosses on the extension. Insert two pins "A" into the two aligned holes of the boom head and extension and install retainers on them.
3. With the jib assembly carefully supported by, and secured to a fork lift, release the jib-to-extension retainer pin. Remove the two pins "B" that connect the jib to the jib transition bracket in the stowed position.
4. Carefully remove the jib assembly and set it safely to the side for temporary storage until reassembled for use with the extension.
5. Remove the stowage bar retainer. Extend the boom slowly until the extension slider pins clear their mating pockets and the extension hook clears the extension alignment ramp. Remove the stowage bar.
6. Use a tag line to swing the extension into alignment with the main boom. The four remaining pin bosses on the boom head should now be aligned with the pin bosses on the extension. Insert four additional pins "A" into the four aligned pairs of bosses on the boom head and extension. Install retainers on all pins "A". If needed to aid with alignment of the 4th pin, a forklift or other appropriate equipment may be used to lift the extension slightly. Select a lifting point near the extension head. Lift from the lower main structural members using nylon slings or padding between lifting device and extension to avoid damage.
7. Rigging with the extension only does not require the jib transition bracket or the ratchet plates. Remove the two lower pins "C" securing the jib transition bracket to the extension tip and the two ratchet bolts retaining the ratchet plates and remove the jib transition and ratchet plates.
8. Install the extension lower sheave (removed from the jib tip). Route the wire rope from the auxiliary winch drum over the top wire rope guide in the boom head and over the extension upper and lower sheaves. Make sure the upper and lower wire rope guide pins are in place.



Do not route the wire rope under the top guide in the boom head.

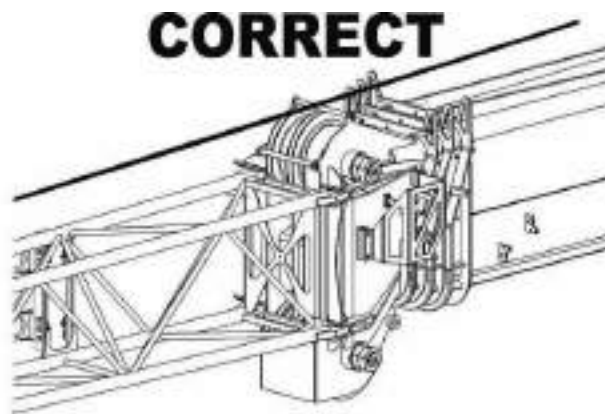
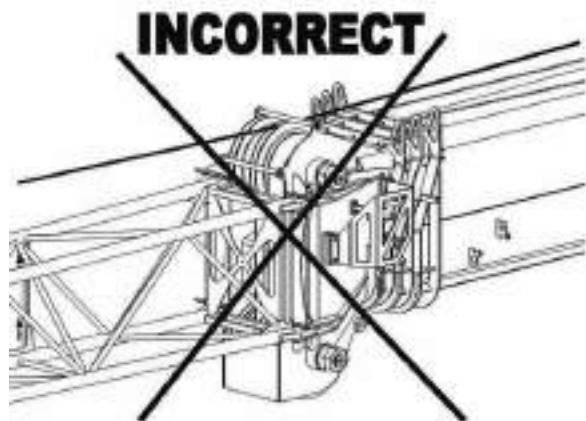

9. For 1-part rigging, install the wedge and socket (becket) and overhaul ball.
10. For 2-part rigging, route the wire rope end around the hook block sheave. Install the becket and attach it to the dead end anchor point on the extension tip.

OPERATING INSTRUCTIONS

11. Install the A2B jumper cable between the boom head and extension. Plug the male connectors into the female receptacles. Install the A2B switch on the end of the wire rope retainer pin and plug it into its receptacle.



Use caution to insure that the A2B wiring does not become damaged during setup, use, or stowage of the extension. Damage to the wiring can cause the A2B shut-down feature to malfunction, which could result in damage to the equipment and/or injury to the operator.

3.34.2 Stowing the Extension

1. Retract the boom fully and lower it to a horizontal position. Remove the wire rope guides and retainers at the upper and lower extension sheaves.
2. Remove the becket and overhaul ball; retract the wire rope onto the auxiliary winch drum and secure it. Remove the extension lower sheave.
3. Unplug the A2B switch at the pivot location near the extension lower sheave and remove it from its pivot location. Remove the A2B jumper cable between the boom head and extension.
4. Install the jib transition bracket and the two lower pins "C," securing it to the extension tip. Install the ratchet plates and ratchet plate retainer bolts, making sure that the bolts are seated in the 0° offset position.
5. With the jib assembly firmly restrained, use a forklift to lift the jib assembly into place. Reinstall the jib assembly by inserting the two connection pins "B," which connect the jib to the jib transition bracket in the stowed position. Reinsert the jib-to-extension retainer pin to fully support the jib assembly.
6. Extend the boom approximately 3 ft (1 meter). Remove all but the two far right pins "A" from the extension and main boom bosses. Swing the jib and extension back alongside the main boom.

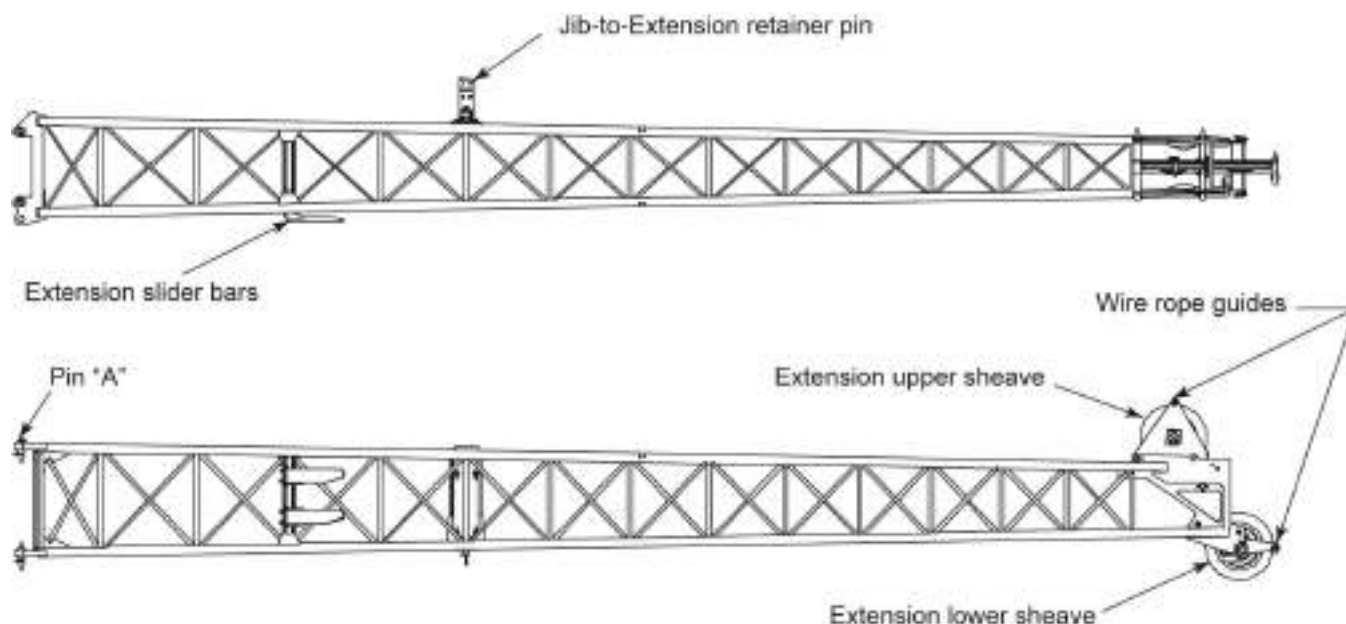

OPERATING INSTRUCTIONS

7. Raise the boom to approximately 30° above horizontal, or until the extension settles fully on its stowage brackets. Lower the boom to horizontal and install the extension stowage bar and retainers at the extension slider pin locations on the main boom.
8. Remove the pins “A,” attaching the extension to the far right pin bosses on the boom head. Stow these pins and their retainers in the stowage bracket provided for them at the base of the extension weldment.

3.34.3 Erecting and Rigging the Extension and Jib

Follow the steps below to erect the extension and jib from their stowed position.

1. Retract the boom fully and lower it to a horizontal position.
2. The two far right pin bosses on the boom head should be aligned with the pin bosses on the extension. Insert two pins “A” into the two aligned holes of the boom head and extension and install retainers on them.
3. Attach a tag line to the lower chord of the extension near the butt end of the main boom. Remove the retainers from the extension stowage bar.
4. Raise the boom to a position slightly above horizontal. Extend the boom slowly until the extension slider pins clear their mating pockets and the extension hook clears the extension alignment ramp. Remove the stowage bar.
5. Lower the boom to a full horizontal position. Use the tag line to swing the extension and jib into alignment with the main boom. The four remaining pin bosses on the boom head should now be aligned with the pin bosses on the extension. Insert four additional pins “A” into the four aligned pairs of bosses on the boom head and extension. Install retainers on all pins “A.”. If needed to aid with alignment of the 4th pin, a forklift or other appropriate equipment may be used to lift the extension slightly. Select a lifting point near the extension head. Lift from the lower main structural members using nylon slings or padding between lifting device and extension to avoid damage.
6. Install the jib tip sheave if it is not already in place.
7. Attach a tag line to a lower chord of the jib tip. Unlock the jib-to-extension retainer pin and swing the jib into alignment with the extension. The two remaining pin bosses on the jib transition bracket should now be aligned with the pin bosses on the jib. Insert two additional pins “B” into the two aligned pairs of bosses on the transition bracket and jib. Install retainers on all pins “B.”
8. If needed, the offset adjustment hook can be used to assist in alignment for inserting the final pin “B.” Route wire rope as described in steps 9, 10, and 12. Winch up slowly to aid in alignment of holes.
9. Route the wire rope from the auxiliary winch drum over the top wire rope guide in the boom head and over the extension upper sheave and over the jib tip sheave. Install the wire rope guide at the top extension sheave and the two guides at the jib tip sheave. Check to see that all pins and retainers are properly installed and secured.

OPERATING INSTRUCTIONS



Do not route the wire rope under the top guide in the boom head.

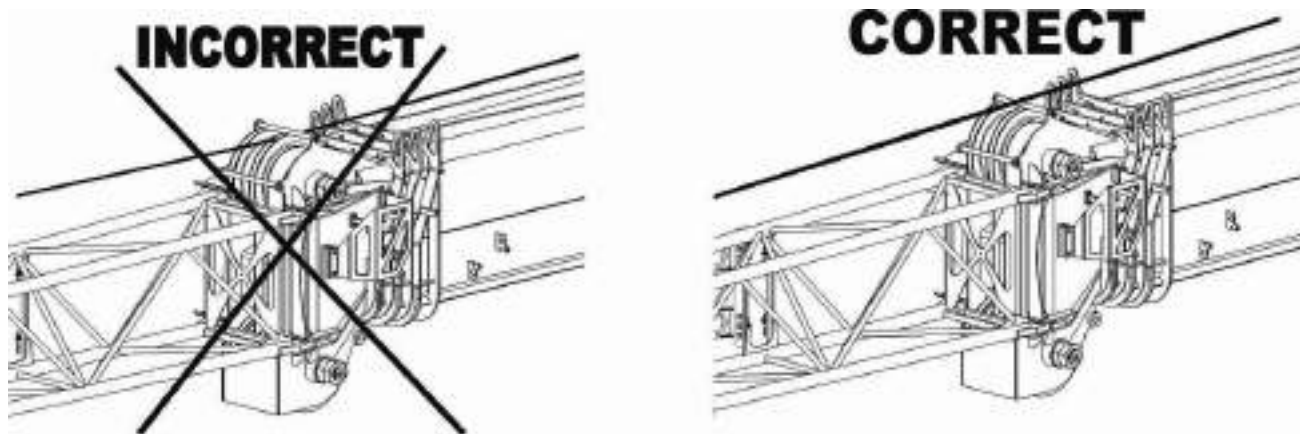

10. Install the wedge and socket (becket) on the end of the wire rope.
11. To offset the jib to 15° or 30° positions, proceed with Step 12. Otherwise skip ahead to Step 15.
12. Connect the becket to the offset adjustment hook on the bottom of the jib.

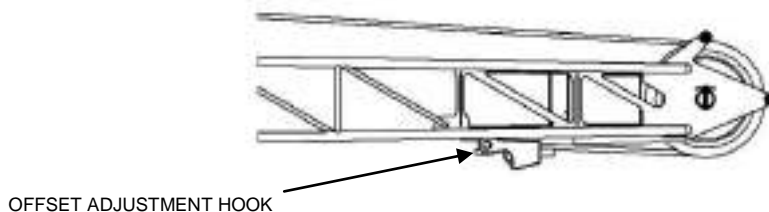

13. Retract the wire rope until there is no pressure on the ratchet bolts and the ratchet plate can swing free of the bolts.

NOTE

◆ Do not remove the offset ratchet bolts to perform this operation.

OPERATING INSTRUCTIONS

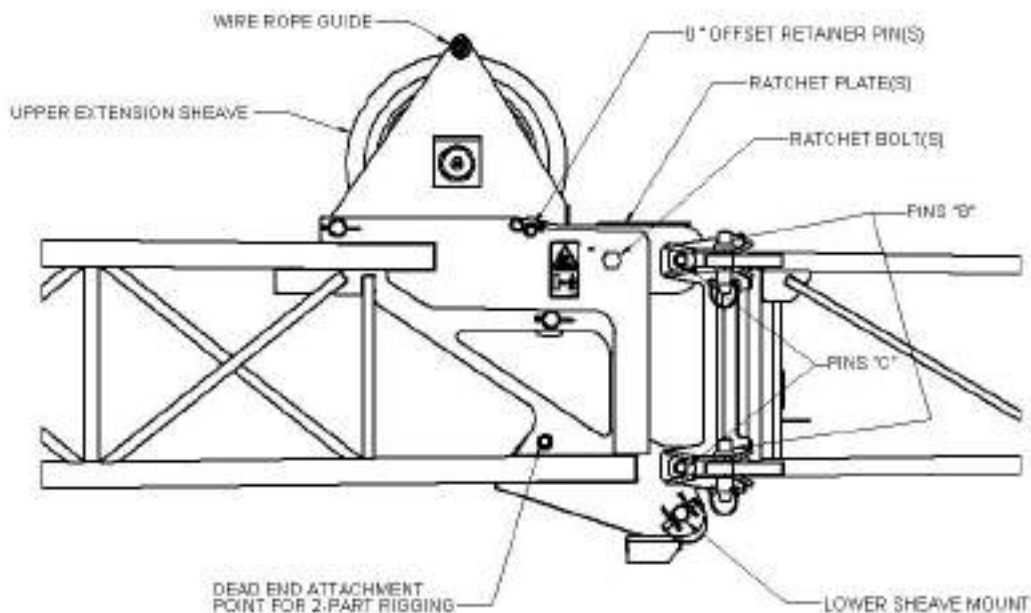

14. Using a pry bar, lift the ratchet plates and hold them clear of the ratchet bolts. Extend the wire rope slowly. When the ratchet bolts begin to slip into the proper notch (2nd notch = 15° offset, 3rd notch = 30°) in the ratchet plates, remove the pry bar. Continue extending the wire rope slowly until the weight of the jib has been transferred from the wire rope to the ratchet bolts and the rope becomes slack.



DO NOT lift the ratchet plates with your hands; always use a pry bar and keep your hands completely clear of all pinch points.

15. Install the overhaul ball.
16. Install A2B jumper cables between the boom head and extension and between the extension and jib. Plug the male connectors into the female receptacles. Install the A2B switch on the LH end of the wire rope retainer pin (T) and plug it into its receptacle.



Use caution to insure that the A2B wiring does not become damaged during setup, use, adjustment, or stowage of the jib or extension. Always make sure that the main cables and A2B jumper cables do not become stretched or pinched, especially at the transition joint between the jib and extension. Damage to the wiring can cause the A2B shut-down feature to malfunction, which could result in damage to the equipment and/or injury to the operator.

OPERATING INSTRUCTIONS

3.34.4 Stowing the Extension and Jib

1. If the jib is in the 15° or 30° offset position, proceed with Step 2. Otherwise skip ahead to Step 5.
2. Retract the boom fully and lower it to a horizontal position. Remove the overhaul ball and attach the becket to the offset adjustment hook on the bottom of the jib.
3. Retract the wire rope until the jib is returned to the 0° offset position and the ratchet bolts slip into the 0° notches of the ratchet plates and become firmly seated. Extend the wire rope until the rope becomes slack and install and secure the 0° offset retaining pins. Return the boom to the horizontal position.
4. Remove the wire rope guide and retainer at the top extension tip sheave and the two guides and retainers at the jib tip sheave.
5. Remove the becket and overhaul ball; retract the wire rope onto the auxiliary winch drum and secure it. Remove the jib tip sheave.
6. Attach a tag line to a lower chord of the jib tip. Remove the two pins “B” and their retainers from the right side bosses on the jib transition bracket. Swing the jib back alongside the extension until the jib-to-extension retaining pin locks the jib and extension together.
7. Extend the boom approximately 3 ft (1 meter). Remove all but the two far right pins “A” from the extension bosses. Swing the extension and jib back alongside the main boom.
8. While holding pressure on the tag line to force the jib and extension toward the boom, slowly retract the boom. Watch to make sure that all hooks, slider pins, and corresponding mounts are engaging properly. Retract the boom as far as it will go.
9. Raise the boom to approximately 30° above horizontal, or until the extension and jib settle fully on their stowage brackets. Lower the boom to horizontal and install the retainers onto the extension stowage bar.
10. Recheck all pin retainers; make sure that the jib-to-extension retaining pin is securely set.
11. Remove the pins “A” attaching the extension to the far right pin bosses on the boom head. Stow these pins and their retainers in the bracket provided at the base end of the extension.

MAINTENANCE

SECTION 4. MAINTENANCE

4.1 LUBRICATION AND MAINTENANCE

Proper and timely lubrication and maintenance are essential for satisfactory performance of the 10010MX. Refer to the sections on lubrication and service in this manual.

Tighten all nuts, bolts, and hydraulic and electrical connectors on the crane after the first 100 hours of operation, and then periodically re-inspect them to make sure that everything remains tight.

At least once a month, do a thorough walk-around inspection of the crane. Finding and correcting minor problems before they become serious can prevent considerable downtime.

Before removing inspection covers, panels, filler caps, etc., from any part of the crane, clean away all dirt around the opening. Keep all fuel and lubricants clean; use only fuel and lubricants that you know are clean. Keep all filler caps in place except when you are actually adding fluid and then replace them promptly.

If you experience any operating or service problems, contact your Tadano Mantis dealer or the factory immediately.

4.2 MAINTENANCE INTERVALS

The maintenance intervals depend on the vehicle's operating conditions; the next maintenance will be due after a certain number of operating hours or a defined period of time.

NOTE

◆The value that is reached first shall be decisive.

The number of operating hours is indicated in the hour meter on the system monitor.

Maintenance work performed earlier than the regular maintenance work, or in a different fashion, is indicated in the maintenance schedule in the column "Initial maintenance after" (e.g. commissioning of the machine or replacement of components). After these maintenance works have been completed, the column "Regular maintenance every 50/100/200/500/1000/2000 operating hours" shall apply.

Maintenance work performed daily or before commissioning the vehicle has been marked by an "X" in the column "Daily, before startup."

Once the number of operating hours has been reached, the specified maintenance work that needs to be performed repeatedly have been marked by an "X" in the columns "Regular maintenance every 50/100/200/500/1000/2000 operating hours" (e.g. "Every 500 operating hours, after 500, 1000, 1500, etc. operating hours have been reached or "Every 2000 operating hours, after 2000, 4000, 6000, etc. operating hours have been reached).

NOTE

◆The maintenance intervals apply for machines that are subject to normal operating and environmental conditions. If the machines are used in particular applications, adapt the maintenance intervals to the prevailing operating conditions.

NOTE

◆Whenever major maintenance work is performed, also perform maintenance work to be done at shorter intervals that coincides with this date.

NOTE

◆In the inspection and maintenance plans, the maintenance works are shown in terms of assemblies.

MAINTENANCE

Assemblies / Maintenance Work and Inspections	Reference	Initial Maintenance After	Regular Maintenance Every						Minimum Intervals	Remarks	
			Daily; Before Start-up	50/ Weekly	100	200	500	1000			2000
			Operating Hours								
Engine	4.3										
Check oil level	4.3.1		X							Check at dipstick	
Check for leaks			X							Repair, See Capacities & Specifications Chart	
Change oil and filter	4.3.2					X			Every 6 months	See Manufacturer Maintenance manual	
Clean crankcase breather					X						
Cooling System	4.5										
Check coolant level	4.5.1		X							Check "cold," add as required	
Check for leaks and hose clamp tightness			X							Repair, See Capacities & Specifications Chart	
Flush system and replace coolant	4.5.2							X	Every 2 years		
Clean radiator	4.6					X					
Fuel System	4.4										
Check fuel level			X							Fill at end of each day	
Drain fuel/water separator	4.4.3		X								
Drain dirty fuel				X						Drain until clean fuel evident	
Replace fuel filter	4.4.4				X					See Engine Manufacturer Maintenance manual	
Drain water/sediment	4.4.1				X						
Clean fuel inlet & screen	4.4.2				X						
Air Supply	4.7										
Clean air pre-cleaner			X								
Hydraulic System	4.9										
Check hydraulic oil level	4.9.1		X							Check for "desired level" at tank sight gage, all cylinders fully retracted and oil at operating temperature. Add as required, see Capacities & Specification Chart.	
Check filter condition indicator			X								
Check for leaks	4.9		X							"Walk around" inspection of entire machine, repair as required.	
Clean hydraulic tank										Clean with solvent.	
Change hydraulic oil	4.9.3							X	Every 2 years	Drain, clean, and refill. See Capacities & Specification Chart. Analyze an oil sample with each oil change.	
Change hydraulic filters	4.9.2	100 hrs					X		Once per year	Change as required, or at least every 1000 hours.	
Replace hydraulic hoses									Every 6 years		
Clean oil cooler fins	4.9.7				X						
Check fan for proper operation	4.9.7						X				

MAINTENANCE

Assemblies / Maintenance Work and Inspections	Reference	Initial Maintenance After	Regular Maintenance Every					Minimum Intervals	Remarks		
			Daily; Before Start-up	50/ Weekly	100	200	500			1000	2000
			Operating Hours								
Engine	4.3										
Travel/Tracks											
Check track drive reducers	4.17.1			X					Check level at "level" plug with "fill" and "drain" plugs in vertical alignment. Add as required. See Capacities & Specification Chart.		
Check/Adjust track tension	4.17.2			X							
Clean/Grease extend beams	4.17.3			X							
Inspect undercarriage	4.17.4						X				
Winches	4.15										
Mounting Bolts	4.15	100 hrs						X	Every 6 months		
Check oil level	4.15.1						X		Every 3 months		
Check for leaks			X						Repair as required		
Change oil	4.15.2	100 hrs						X	Every 6 months		
Check wire rope	4.19.1		X								
Inspect winch drum	4.19.4						X		Before installing new winch rope.		
Boom											
Grease sheaves	4.20.1			X					Inspect for damage, replace as required. See Capacities & Specifications Chart.		
Grease extend sheaves	4.20.1			X					Align holes in second, third, and fourth sections to grease extend sheaves. Inspect for damage, replace as required. See Capacities & Specifications Chart.		
Grease boom bearing pads	4.20.1			X					Inspect for damage, replace as required. See Capacities & Specifications Chart.		
Grease boom pins	4.20.1			X					Inspect for damage, replace as required. See Capacities & Specifications Chart.		
Swing System	4.14										
Check for leaks	4.14.1		X								
Check for proper operation			X						Once per year		
Inspect swing drive reducer visually	4.14		X						Every 3 years		
Check swing drive reducer oil level	4.14.1				X				Once per month		
Check fasteners on slew ring and swing drive for tightness.	4.14.3 4.14.9	100 hrs					X		Comply with recommended torque values.		
Change swing drive reducer oil	4.14.2	200 hrs						X	Once per year		
Change swing brake oil	4.14.4							X			
Inspect swing brake	4.14.6							X			
Grease slew ring race	4.14.9			X					Grease while rotating until grease is visible at seal. See Capacities & Specifications Chart.		
Grease slew ring teeth	4.14.8			X					Check for damage, replace as required.		

MAINTENANCE

Assemblies / Maintenance Work and Inspections	Reference	Initial Maintenance After	Regular Maintenance Every						Minimum Intervals	Remarks	
			Daily; Before Start-up	50/ Weekly	100	200	500	1000			2000
			Operating Hours								
Electrical equipment	4.12										
Check the batteries	4.12.1				X						
Check the starter	4.12.4							X			
Check display and indicator lamps for operation/damage	4.12.6		X								
Check load moment indicator for proper operation			X								
Check load moment indicator							X			Check with calibrated weights and adjust if necessary.	
Crane Cab	4.20										
Lubricate all joints, pins, hinges, and movable components.	4.20				X				Every two weeks	And after every crane cleaning with pressure washer.	
Treat door locks								X	Once per year		
Air conditioning system	4.20.1							X	Once per year	Perform inspection.	
Clean wiper blade elements	4.20.3					X			Once per month	More frequently if necessary.	
Replace wiper blade elements	4.20.3							X	Once per year	Or if damaged.	
Check washer fluid level	4.20.3					X				More frequently if necessary.	
Check/Clean/Replace air filter	4.20.2					X					
Auxiliary Generator (Option)											
Check oil level					X						
Change oil					X						
Replace air cleaner element						X				Clean cooling air flow path.	
Clean fins						X					
Other lubrication points	4.21										
Lubricate all joints, pins, hinges, and movable components.	4.21				X				Every two weeks	And after every crane cleaning with pressure washer.	
Cab Instrumentation											
Check for proper operation			X							Repair or replace as required.	

MAINTENANCE

4.3 ENGINE



When handling fuel or consumables, do not smoke or do not use open flames.



Perform maintenance work only while the engine is stopped.



Depressurize systems such as the radiator and expansion vessels before opening them.

The following are general inspection, servicing and maintenance operations of the engine:

- Check engine oil level
- Change engine oil
- Replace lubricating oil filter
- Replace fuel filter cartridges
- Inspect v-belt for good condition
- Inspect valve clearance
- Check engine for leakage at regular intervals

Troubleshooting has been described in the operating manual of the engine manufacturer that is supplied with the machine.

4.3.1 Inspecting Oil Level

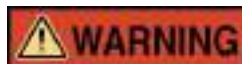

Never operate the engine with oil level below the L (low) mark or above the H (high) mark on the engine dipstick. Poor engine performance or engine damage can occur.

1. The engine *must* be level when checking the oil level to make sure the measurement is correct.
2. Shut off the engine for an accurate reading.
3. Wait at least fifteen minutes after shutting off the engine to check the oil level. This allows time for the engine to drain into the oil pan.

MAINTENANCE

4.3.2 Changing Oil/ Replacing the Oil Filter

NOTE

◆ Oil change and oil filter replacement should take place every 500 operating hours; at least, however, *once per year*. The specifications of consumables of the engine manufacturer must be complied with.

Some sources have determined that used engine oil can be carcinogenic and cause reproductive toxicity. Avoid inhalation of vapors, ingestion, and prolonged contact with used engine oil.

If not reused, dispose of oil in accordance with local environmental regulations.

To reduce the possibility of personal injury, avoid direct contact of hot oil with your skin.

For detailed oil change procedures, refer to engine manufacturer instructions.

For lubrication oil specifications and capacities refer to capacities and specifications table at the end of the maintenance section of this manual.



4.3.3 Inspecting Hose Clamps of the Charge Air Hoses

NOTE

◆ The hose clamps of the charge air hoses are equipped with cup springs on the threaded housing. When re-tightening the hose clamps, do not over-tighten.

Check the hose clamps of the engine charge air hoses for tight fit according to the maintenance schedule.

4.4 FUEL TANK

4.4.1 Draining Condensation Water from Tank

Under extreme weather conditions, condensation may form in the fuel tank. Operate the vehicle until the fuel level is low (< 1/8 tank); unscrew the drain plug from the tank bottom and drain condensed water into an appropriate vessel. Leave the drain port open until clean fuel flows out.

4.4.2 Cleaning Fuel Strainer in the Filler Cap

The filler cap for fuel is located on the cab side behind the hydraulic tank, under the fuel access door.

- Open the fuel tank access door, remove the fuel strainer, and clean it in a clean vessel using a cleaning agent or diesel fuel; check and replace, if necessary.
- Subsequently, blow the fuel strainer out using compressed air.
- Reposition the fuel strainer and shut fuel tank access door.

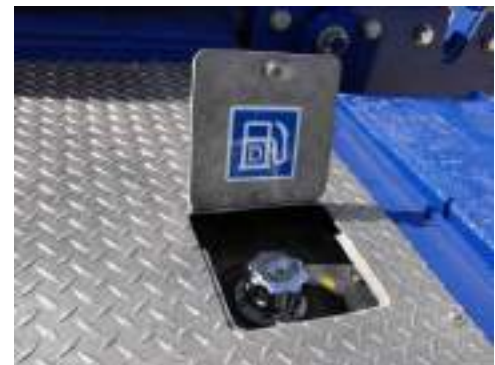

MAINTENANCE

4.4.3 Draining Condensation Water from Separator

Open the drain valve of the fuel/water separator and allow the collected condensation water to drain into an appropriate vessel.

4.4.4 Replacing Fuel/Water Separators

1. Drain the entire filter contents of the fuel/water separator.
2. Disconnect the electrical connector from the bottom of the filter.
3. Disconnect the filter from the filter top together with the filter base.
4. Grease new sealing elements with diesel fuel and insert them into the gaskets.
5. Screw-fasten filter base by hand to the new filter cartridge to filter top.
6. Tighten all components securely and reattach the electrical connector.
7. Bleed system.



4.5 WATER-COOLED ENGINE COOLING SYSTEMS

- Inspect the cooling system for leaks and trash buildup. Clean any accumulation with compressed air or high-pressure water.
- Inspect the water pump for leaks.

NOTE

◆The water pump seal is lubricated by the engine coolant. A small amount of leakage as the engine cools down and parts contract is acceptable.

- Inspect the system hoses and crankcase breather hose for cracks and loose clamps.
- Inspect the fan and accessory drive belts for cracks, breaks, or other damage. Check for proper belt tension.

NOTE

◆The cooling system filler cap is located on top of the radiator and can be accessed through the fluids access door on the engine-side covers.

4.5.1 Coolant Level



Do not remove the pressure cap from a hot engine. Wait until the coolant temperature is below 50°C before removing the pressure cap. Heated coolant spray or steam can cause personal injury.

- Check the coolant level with the engine stopped and cold. Remove the filler cap slowly to relieve pressure gradually.
- Maintain the coolant level to within ½ in (13 mm) of the bottom of the fill pipe. Install the filler cap.

MAINTENANCE



To prevent engine damage, never add coolant to an overheated engine. Allow the engine to cool first.

- The 10010MX engine is equipped with a variable speed cooling fan, allowing the engine to match the cooling capacity with the loads and conditions under which it is operating. At startup, the fan will be fully engaged until the engine rpm reach sufficient speed to disengage the fan's slip clutch--at this point significant decrease engine noise will be observed. After this, the engine ECM will control the fan speed based on load and conditions.
- After starting, operate the engine at slow speed until it reaches operating temperature. Check the coolant level and add coolant if necessary. Check for any obvious cooling system leaks or loose connections. Inspect the water pump for evidence of leaks.
- Inspect the fan and accessory drive belts for cracks, breaks, or other damage. Check for proper belt tension.

4.5.2 Draining Coolant

NOTE

◆Before the coolant is replaced, open the vehicle's warm water heating.

Drain the cooling system by opening the drain valve on the radiator and removing the plug in the bottom of the water inlet. A drain pan with a capacity of nineteen liters will be adequate in most applications.

Check for damaged hoses and loose or damaged hose clamps. Replace as necessary. Check the radiator for leaks, damage, and buildup of dirt. Clean and replace as necessary.

1. Install the drain plug and pour in coolant mix via the overflow tank.
2. Start the engine and make it run at various speed levels for approximately one minute.
3. Stop the engine and check the coolant level in the overflow tank; top off, if necessary.

NOTE

◆Dispose of coolant in an environmentally responsible fashion.

NOTE

◆For instructions on how to drain the entire coolant from the engine, refer to the engine manufacturer's operating manual.

4.6 CLEANING THE RADIATOR

Depending on the dust collected, clean the cooler fins of the charge air and water cooler by flushing with compressed air or using a clean paint brush.

MAINTENANCE

4.7 AIR CLEANER



Service the air cleaner only while the engine is not running.
Switch battery main switch off.



Do not start the engine while the cleaner element is not installed.

NOTE

◆ In addition to the normal replacement intervals, the air cleaner cartridge need only be replaced if the “engine air inlet clogging” error is displayed on the A6 cab display while the engine is running. At the same time, clean the air cleaner housing.



4.7.1 Removing / Installing the Filter Cartridge

1. Remove the cover from the filter housing.
2. Pull the air cleaner out of the filter housing.
3. Clean the filter housing and the sealing surfaces of the filter housing and the cover carefully using a lint-free piece of cloth.
4. Insert new filter cartridge carefully into the housing. Make sure that the sealing surfaces are in perfect condition.
5. Mount the cover.

During assembly, make sure the filter cartridge and housing cover fit perfectly.

MAINTENANCE



Do not blow-clean using compressed air. Make sure that no dust can enter the engine's air intake system while the air cleaner housing is being cleaned.

4.7.2 Filter Cartridge

Check *new* filter cartridge before installation.



On no account may a filter cartridge be used that shows visible damage (dents, deteriorated filter surface, etc.). Replace damaged filter cartridges immediately.

Filter Maintenance Instructions

- Filter servicing requires absolute precision and reliability; inappropriate filter servicing may damage the engine.
- Do *not* perform maintenance depending on the result of the visual inspection of the cartridge. If a filter cartridge is functioning properly, it must look dirty.
- Never clean the filter cartridge by:
 - Knocking
 - Washing
 - Blowing
 - Other cleaning procedures

Filter cartridges must be disposed of normally and never be incinerated.

4.7.3 Air Intake Pipes and Hoses

- Check all hose connections between the filter and the engine and the charge air hoses for tight fit. Use screw-type hose clamps only.
- Check hoses and pipes for porosity and cracks.

4.7.4 Inspecting Air Inlet Vacuum Switch

- If the “engine air inlet clogging” error does not go on despite the air cleaner being contaminated, check the electric vacuum switch for proper working order.
- Monitor the air cleaner for proper working order.
- Once the engine is running, reduce air cleaner intake opening *gradually* by covering it (e.g. using cardboard or sheet metal), until the air cleaner pilot lamp goes on.



After “engine air inlet clogging” error is shown on the display, do not reduce the intake opening further without risking damage.

MAINTENANCE

4.8 EXHAUST SYSTEM

The exhaust system does not require any particular service or maintenance.

4.9 HYDRAULIC SYSTEM



Perform work on the hydraulic system only while engine is stopped.

- Check and retighten the screw couplings of the hydraulic assemblies and pipes.
- Check hydraulic system for leakage at regular intervals.



Close the shut-off valves only in case of repair work (e.g. at the hydraulic pumps).

4.9.1 Inspecting Oil Level

NOTE

◆ Check the oil level on the gauge on the display.

NOTE

◆ Check the oil level while the engine is stopped and while the telescope cylinders and the boom elevation cylinder are retracted.

Superstructure in transport position / oil temperature is approximately +20°C.

- Unscrew the filter-breather and pour in the oil through the port.
- Check cover seal and replace if necessary.
- Re-position and fasten the cover.
- Close servicing lid again.



Make sure that only new oil is poured in from clean vessels.

MAINTENANCE

4.9.2 Replacing Filter Cartridges



Replace the filter cartridges only while the engine is stopped.

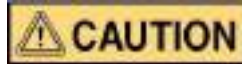

- ❖ The individual components installed in the valves, pumps and hydraulic motors have deliberately narrow tolerances. Even very small impurities penetrating the hydraulic system may cause malfunctions.
- ❖ Replace the filter cartridge during every oil change to the hydraulic system, when the “pilot filter clogging” or “return filter clogging” warnings come on and according to the maintenance schedule. Do not attempt to clean the filter cartridge.

Prior to filter cartridge replacement, retract the boom hoist, boom extend, and track extend cylinders.

- Release the securing bolts and remove the cap assembly with bypass valve.
- Remove the filter cartridge; allow the residual oil to drip.
- Check the cap o-ring seal and replace if necessary.
- Clean the sealing surfaces using a lint-free cloth.
- Make sure that the seal fits correctly.
- Install the cap assembly and secure in place with the mounting bolts.
- If the filling strainer is contaminated or clogged, open the ventilation filter and clean the filling strainer.

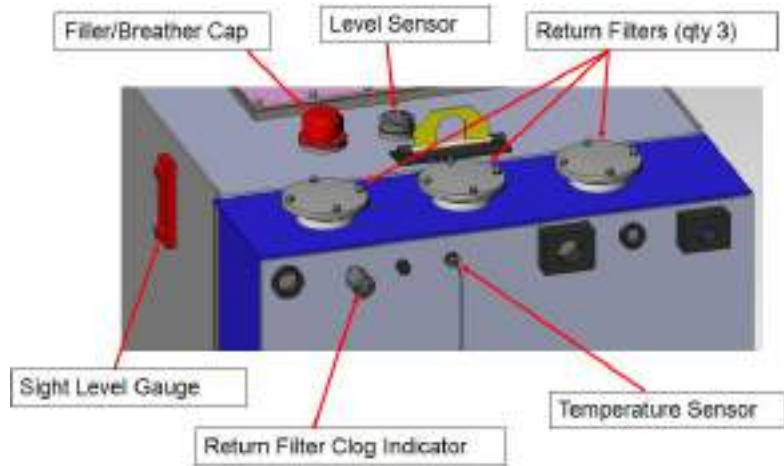

MAINTENANCE

4.9.3 Changing Oil



Perform oil change only while the engine is not running.

Prior to an oil change, retract the boom hoist, boom extend, and track extend cylinders.

- Close the butterfly valves in the suction ports of the hydraulic tank.
- Remove the drain plug and drain the oil completely into an appropriate tank.
- Once work is finished, clean the sealing surfaces; clean, check, and if necessary replace the sealing element, then close the oil tank by means of the drain plug.
- Replace the filter.
- Pour in new oil.
- Remove any impurities that might be present.
- Re-open the butterfly valves in the suction ports of the hydraulic tank.



Before starting the engine, ensure the butterfly valves in the hydraulic tank suction ports are open.

NOTE

◆It is recommended to have oil analyzed by the oil supplier before carrying out a scheduled oil change, or at regular intervals, to see if an oil change is necessary.

Pour in only clean oil on an oil change. Depending on the degree of contamination and the thermal load the hydraulic oil is subject to, shorter oil change intervals than those specified in the maintenance schedule may be required.

Dispose of filters and used oil in an environmentally responsible fashion.

4.9.4 Changing Oil Type

The hydraulic system can be converted to biodegradable oils according to VDMA 23568.



When changing over the hydraulic system from oils based on mineral oil to biodegradable oils, make sure to comply with the directives of VDMA 24569.

MAINTENANCE

4.9.5 Hydraulic Fittings

- Check piping systems for leakage according to the maintenance schedule.
- In case of leakage of the adjustable screw couplings and assemblies, proceed as follows:
 - Release cap nuts on the piping systems or hose pipes
 - Tight the adjustable screw couplings in the assemblies safely
 - Fasten the cap nuts of the piping systems and hose pipes
- Perfectly sealing condition is only ensured if the above sequence of operations is observed and compiled with.
- In case of leakage at the cap nuts of the piping systems, check cap nuts for tight fit; if necessary replace the screw coupling.

4.9.6 Checking Fittings

Release the cap nut and check whether the gap between the packing ring and the retaining ring is closed.

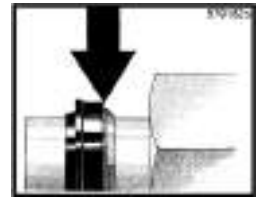

4.9.7 Oil Cooler

- Clean cooler fins with compressed air, depending on dust accumulated.
- Check fan and thermostatic valve for proper working order.

4.9.8 Maintenance Instructions for Hydraulic Cylinders

- Before commissioning, bleed the hydraulic cylinders.
- Bleeding may only be finished when no more bubbles appear.
- Bleeding must be repeated whenever hydraulic components or pipelines have been assembled or disassembled.
- When machines are operating outdoors, bleed the hydraulic cylinders at regular intervals.

MAINTENANCE

4.10 SPEEDS OF HYDRAULIC FUNCTIONS

The table indicates the specified speed set-point of the working hydraulics, at the specified engine speed, for testing purposes.

NOTE

◆Precise measurements are only possible after air has been bled from the hydraulic system. The hydraulic pumps must be bled properly and the hydraulic temperature should be approximately 30–40⁰ C (86–104⁰ F).

4.10.1 Speed Set-points of the Hydraulic System

Function	Setting	Speed Set-Point
Main Winch	High	98 rpm
	Low	49 rpm
Aux Winch	High	98 rpm
	Low	49 rpm
Boom Telescope	Extend	51 s
	Retract	1 min 6 s
Boom Hoist	Raise	44 s
	Lower	47 s
Swing		27 s/rot.
Travel Speed	High	1.5 mph (2.4 km/hr)
	Low	0.9 mph (1.5 km/hr)

4.10.2 Speed Setting Tolerances

NOTE

◆A general setting tolerance of -5% / +10% in relation to the set-point applies to all the indicated time and speed-values.

4.11 HYDRAULIC SYSTEM PRESSURE CHECKS

In the case of an operating malfunction of the hydraulic system, the set-point pressures of the various pressure ranges can be checked by connecting hydraulic pressure gauges to the pump, load sense, and pilot pressure port in the test port manifold.

Pressures are checked by dead-heading the function (blocking the ports and/or checking cylinders at fully retracted or fully extended conditions) and reading pressure from the load sense test port.

NOTE

◆Precise measurements are only possible after air has been bled from the hydraulic system. The hydraulic pumps must be bled properly and the hydraulic temperature should be approximately 30–40⁰ C (86–104⁰ F).

Bleed the hydraulic pumps before the pressure setting. The system is bled properly when the hydraulic oil escapes by taking appropriate measures; after completing bleeding and setting, clean the components, removing residual oil.

MAINTENANCE

4.11.1 Hydraulic System Pressure and Flow Settings

10010MX PRESSURE & FLOW SETTINGS		
CRANE FUNCTION	NOMINAL PRESSURE SETTING	NOMINAL FLOW SETTING
Main Winch Raise/Lower	4300/2900 PSI 296/200 BAR	35 gal/min 132 L/min
Aux Winch Raise/Lower	4300/2900 PSI 296/200 BAR	35 gal/min 132 L/min
Boom Tele Extend/Retract	2500/3000 PSI 172/207 BAR	52/17 gal/min 196/64 L/min
Boom Hoist Extend/Retract	2750/3000 PSI 190/207 BAR	50/25 gal/min 189/95 L/min
Swing	3000 PSI 207 BAR	30 gal/min 114 L/min
Track Drive	4800 PSI 331 BAR	50 gal/min 189 L/min
Track Extend	3000 PSI 207 BAR	10 gal/min 38 L/min
Auger (Optional)	2500 PSI 172 BAR	40 gal/min 151 L/min



TEST PORTS

4.11.2 Hydraulic System Pressure Setting Tolerances

Pressure Setting	Lower Tolerance	Upper Tolerance
75 psi to 150 psi (5 bar to 10 bar)	-0	+15 psi (+1 bar)
150 psi to 600 psi (10 bar to 40 bar)	-15 psi (-1 bar)	+15 psi (+1 bar)
600 psi to 3600 psi (40 bar to 250 bar)	-30 psi (-2 bar)	+50 psi (+3 bar)
3600 psi to 5000 psi (250 bar to 400 bar)	-30 psi (-2 bar)	+75 psi (+5 bar)

MAINTENANCE

4.12 ELECTRICAL EQUIPMENT



- ❖ When working on the electrical equipment of the crane, the current circuit must be interrupted by disconnecting the negative terminal “-“cable from the batteries (marked with a minus sign [-] on the battery).
- ❖ Never disconnect the batteries while the engine is running. This might destroy electronic components.

4.12.1 Batteries



- ❖ When checking the acid level, do not smoke or have open flames in the vicinity. Due to chemical reactions, batteries emit highly explosive hydrogen gas. Spilled battery acid must not touch the skin, clothes or the vehicle's paint. Battery acid may cause injuries. Wear protective glasses.
- ❖ If acid contacts skin or the eyes, wash these areas immediately with ample quantities of tap water; if necessary, contact a doctor.

The batteries are located in front of the rear bulkhead plate under the engine-side covers. If the crane operates under normal conditions, the batteries required only little maintenance.

A well-charged battery helps improve the starting process and has a longer service life.

- Check the acid level at regular intervals.
- Fill only with distilled or de-mineralized water. After replenishing, wait approximately thirty minutes, then check the acid.
- Measure the acid density in the individual cells using an acidimeter.

NOTE

◆When the vehicle is to be used under tropical climate conditions, it is essential to take the fluctuations of the acid density into consideration. During the charging process, monitor the acid temperature continuously.

- During the cold season, make sure the batteries have a good charging condition. If the vehicle is standing for an extended period of time, re-charge the batteries.
- The charging current must not exceed 1/10 of the battery capacity.
- Grease the connecting terminals with acid-free and acid-resistant grease (e.g. Vaseline).
- Due to the danger of short circuits, do not place parts conducting electrical current, such as tools, on the batteries.
- A battery-charging pilot lamp that does not go out at increased speed indicates that the batteries are not charged. Find out the reason immediately (e.g. governor or alternator).
- Disconnect any battery chargers that are not protected against the high current drain created when the electric starter engages.

MAINTENANCE

4.12.2 Installing New Batteries

- When installing new batteries, first connect the positive cable (+), then the negative cable (-).
- For removal, reverse the sequence above.

4.12.3 Starting the Engine with Jumper Cables



- ❖ Batteries give off flammable fumes that can explode.
- ❖ Improper jumper cable connections can cause an explosion resulting in personal injury.
- ❖ Prevent sparks near the batteries. Sparks could cause vapors to explode. Do not allow jumper cable ends to contact each other or the engine.
- ❖ Do not smoke when observing the battery electrolyte levels.
- ❖ Always wear protective glasses when working with batteries.
- ❖ Electrolyte is an acid and can cause personal injury if it contacts skin or eyes.
- ❖ Engines installed without separate engine-to frame rail ground straps can be damaged by electrical discharge.
- ❖ To prevent electrical discharge damage, check to make sure the engine's electrical system has a separate engine to frame rail ground strap. For engines that have the alternator connected to an engine component, the ground strap must connect that component to the frame.
- ❖ Some engines have starter-to-frame ground straps, but many of these starters are electrically grounded to the engine. They have electrical insulation systems.
- ❖ For this reason, the starter-to-frame ground strap may not be an acceptable engine ground. When boost starting, refer to the instructions that follow to properly start the engine.

NOTE

◆When using an external electrical source to start your engine, turn the start switch off and turn off all electrical accessories before attaching cables.

- Your engine may be equipped with a 12 or 24-volt starting system. Use only the same voltage for boost starting. Use of a welder or higher voltage will damage the electrical system.
- When using jumper cables, always connect the positive (+) battery cable to the positive (+) battery terminal, which is connected to starter solenoid. Connect the negative (-) cable from external source to the starter negative (-) terminal. If not equipped with a starter negative terminal, connect to the engine block.
- Do not reverse the battery cables. The alternator can be damaged.
- Attach the ground cable last and remove it first.

MAINTENANCE

1. Connect one end of the cable to the positive (+) terminal of the battery being started. Connect the other end to the positive (+) terminal of the power source.
2. Connect one end of the other cable to the negative (-) terminal of the power source.
3. Connect the other end to the starter negative (-) terminal or to the engine block. This prevents potential sparks from igniting combustible gases produced by some batteries.
4. Begin cranking engine to start and achieve idle speed.
5. After the engine starts, disconnect the cable from the starter negative (-) terminal or engine block. Disconnect the other end from the negative (-) terminal of the power source.
6. Disconnect the cable from the positive (+) terminal of the battery on the engine being started. Disconnect the cable from the positive (+) terminal of the power source.

4.12.4 Starter

Refer to the instructions of the engine manufacturer.

4.12.5 Circuit Breaker Panel

The circuit breaker panel is installed in the rear of the right side wall in the operator's cab.

4.12.6 Lamps and Lights

Important machine status and warning information is shown on the display in the cab. If the display is not functioning properly, immediate service is required.

4.13 RATED CAPACITY INDICATOR (RCI)

The rated capacity indicator must be serviced exclusively by qualified service staff.

Every time before the operator puts the machine into operation, he must make sure that:

- RCI is not restricted in its functionality by external destruction
- Anti two-block switch, its weight and chain are correctly mounted
- Electrical cable connections are inserted
- Cables are correctly wound up and tensioned in the electrical cable reel
- Cables are neither damaged nor any strands are broken
- The systems is checked with calibrated weights according to the legal regulations.
- If an essential difference compared to the original setting is detected, re-adjustment must be performed by a specialist.

Tampering with the electronic system of the RCI by unauthorized persons is prohibited.

MAINTENANCE

4.14 SWING MECHANISM



- ❖ Perform work on the swing mechanism only when it is stopped and not subject to load.
- ❖ Before starting work, take precautions to prevent unintended startup.
- ❖ Before starting the vehicle after maintenance or repair works, make sure that there is no one within the danger zone.
- ❖ To enhance safety, check the swing mechanism visually (inside and outside) at intervals of three years.

4.14.1 Checking Correct Oil Level and Leakage

- Check the swing mechanism for leakage at regular intervals, according to the maintenance schedule.
- Defective seals may affect the service life of the swing mechanism considerably.
- Loss of oil or an insufficient oil level in the gearbox may result in damage.
- Check the swing mechanism for leakage at regular intervals, according to the maintenance schedule. If a gearbox becomes leaky or if the oil level is too low, this may result in premature damage.
- Check oil level with the dipstick at regular intervals according to the maintenance schedule, while the gearbox is not moving and after the oil has cooled down.
- The gearbox must be filled with oil; if necessary, pour in an appropriate amount of oil using a funnel or a hose.



Different oil types—even if from the same manufacturer—must not be mixed. Mineral and synthetic oil also must not be mixed.

MAINTENANCE

4.14.2 Changing Oil



Risk of scalding.

Drain oil via the drain port by removing the oil drain plug.

For Trasmittal Bonfiglioli type swing drive reducers, the lube oil is filled at port 1 and the oil level is checked at port 2. Port 2 is equipped with a dipstick to properly measure the capacity. The oil level is required to be between the two marks on the dipstick.

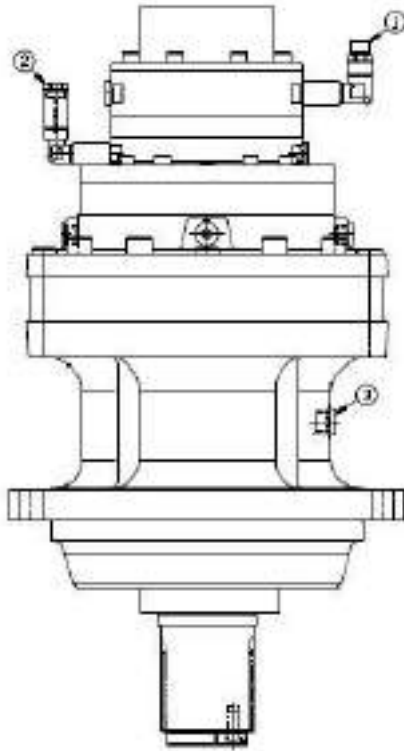

PORT	DESCRIPTION
1	Breather and Oil Fill Port
2	Oil Level Port
3	Drain Port

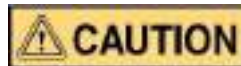

- ❖ Check oil for foreign matter whenever an oil change is performed. Drain oil when it has reached its service temperature.
- ❖ If coarse impurities are detected, they may be due to excessive stress or improper operation. Determine the cause and eliminate it. Dismantle the gear reducer, and check it for damage. If necessary, have the manufacturer perform a general overhaul. Check oil for possible blackening and foreign matter; if necessary, reduce oil change intervals.

MAINTENANCE

4.14.3 Inspecting the Swing Mechanism



Before or after any extended continuous operation, and in case the maximum load is reached frequently, check the screws and bolts located within the load path for proper torque.

Check all screw couplings for proper torque.

Check swing mechanism for abnormal sounds.

4.14.4 Changing the Hydraulic Oil of the Swing Drive Brake



- ❖ **Always engage the swing house lock pin before performing service or maintenance work on the swing brake.**

The swing brake is a “wet” brake and has a sump that should be filled with oil. At the service interval, the brake should be removed, drained of oil, and filled with clean oil. To drain the oil, remove either of the SAE -6 plugs on the side of the brake and drain until empty. After reassembly, the brake should be mounted on the reducer and filled through the top per the Lubrications Specification Table.

4.14.5 Bleeding the Swing Brake

Bleed the service brake after repairs to the hydraulic components of the service brake circuit, before putting the gearbox into operation again (bleed air from brake via bleeder screws).

NOTE

- ◆ Maximum pressure to brake is 3000 psi.

4.14.6 Inspection of the Swing Brake



- ❖ **Always engage the swing house lock pin before performing service or maintenance work on the swing brake.**

Check for proper working order and leakage during operation. When the brake is removed to change the oil, it should also be disassembled to check the internal parts for wear. If the brake is worn or damaged, repair the brake or replace with a new brake. Please do not hesitate to contact your Tadano Mantis Customer Support in case of queries or problems.

4.14.7 Tooth Face Backlash (Swing Motor Gearbox Drive Shaft)

No excessive tooth face backlash is admissible. After the running-in period, the tooth faces show a smooth, bright surface in case of normal wear. If there are other phenomena, such as scrub marks, seizing, pits, flaking, blistering, cracks and plastic deformations, replace the gear wheels. Please do not hesitate to contact your Tadano Mantis Customer Support in case of questions or problems.

MAINTENANCE

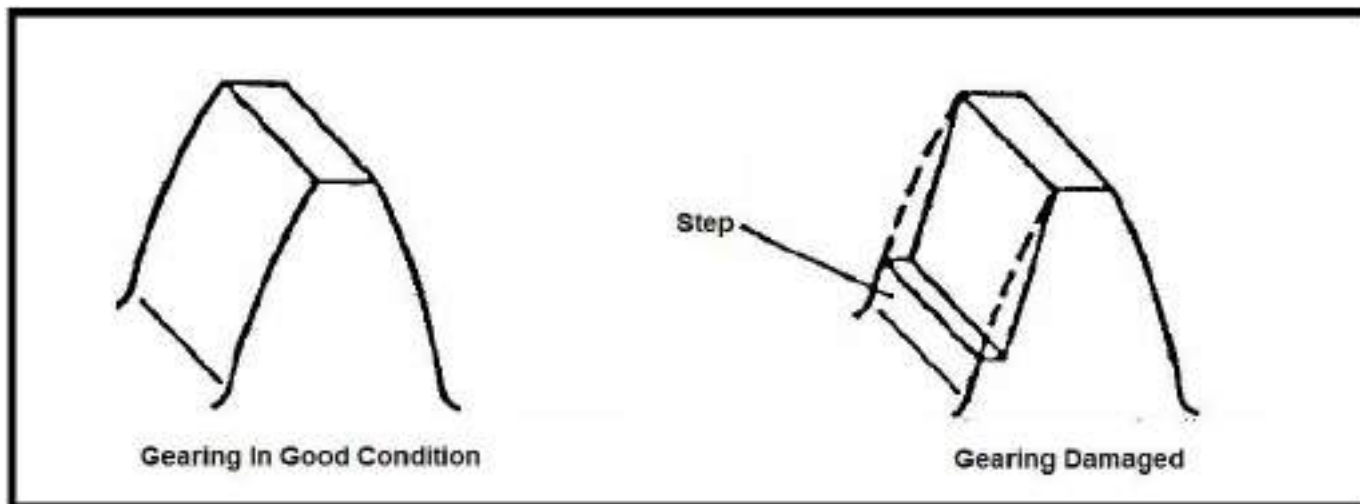

4.14.8 Greasing Slew Ring Gear and Pinion

The lubrication intervals depend on the slewing frequency. Apply the Texaco 'Crater' 2X or 5X grease to the gearing using a paint-brush or a spray gun. Make sure no blank areas are left on the tooth faces.

NOTE

◆ After each cleaning operation of the machine—especially after using a steam-jet unit—check the lubrication of the ring gear and pinion of the swing mechanism. The ring gear and the pinion must always be supplied with lubricant.

4.14.9 Greasing the Slew Ring

Rotate crane slowly while pumping one complete cartridge of EP grease with molybdenum disulfide. Lubricate slew ring at least every two weeks when machine is in service.

- Shorter lubricating intervals may be required in tropical areas, at a high relative humidity, under ambient conditions entailing lots of dust or dirt, and in the case of significant temperature fluctuations.
- Before the crane is put out of operation for an extended time, and before it is restored to operating condition, re-greasing is essential.
- Caution when cleaning the crane—make sure that no water enters into the raceways.
- Once cleaning is finished, lubricate the crane thoroughly.
- The grease filling is to prevent friction, to seal and to protect the assembly against corrosion.
- Use sufficient amounts of grease, so that a grease bead forms around the whole circumference of the bearing grooves.



During slew operation nobody is allowed to stay on the tracks or undercarriage.

MAINTENANCE

4.14.10 Checking Slew Ring Fasteners

Check the slew ring, hydraulic swivel, and swing drive assembly bolts for tight fit according to the maintenance schedule; if necessary, re-tighten.

NOTE

◆ It is essential to use a torque wrench for checking or re-tightening the screws and bolts.

Coarse Thread Size	SAE Grade 8			
	FT. LB.		Newton-Meter	
	*1	**2	*1	**2
1/4-20	9	12	12	16
5/16-18	18	25	25	33
3/8-16	33	44	44	59
7-16-14	52	70	71	94
1/2-13	80	106	108	144
9/16-12	115	154	156	208
5/8-11	159	212	215	287
3/4-10	282	376	382	510
7/8-9	455	606	617	822
1-8	682	909	924	1233
1 1/8-7	966	1288	1309	1746
1 1/4-7	1363	1817	1848	2464
1 3/8-6	1787	2382	2423	3231
1 1/2-6	2371	3162	3215	4288
1 3/4-5	3117	4157	4227	5637
2-4 1/2	4688	6251	6356	8477
2 1/4-4 1/2	6855	9142	9296	12397
2 1/2-4	9375	12503	12713	16953
2 3/4-4	12710	16950	17235	22985
3-4	16791	22391	22768	30364

Coarse Thread	Property Class 10.9		Nominal Wrench Size	
	FT-LB	Newton – Meter	H" Hex Cap Screw "	Wrench Size
	*1 - **2	*1 - **2		
M3	1.0 – 1.4	1.4 – 1.9	M3	5
M4	2.4 – 3.2	3.2 – 4.3	M4	7
M5	4.9 – 6.5	6.6 – 8.8	M5	8
M6	8.3 – 11.0	11.2 – 15.0	M6	10
M8	20.2 – 27.0	27.4 – 36.6	M8	13
M10	40.2 – 53.6	54.5 – 72.6	M10	15
M12	70.2 – 93.6	95.2 – 127	M12	18
M14	112 – 150	152 – 203	M14	21
M16	176 – 234	238 – 318	M16	24
M18	277 – 370	376 – 502	M18	
M20	343 – 458	466 – 621	M20	30
M22	471 – 627	638 – 850	M22(HH)	36
M24	594 – 791	805 – 1073	M24	36
M27	875 – 1167	1187 – 1583	M27(HH)	46
M30	1184 – 1579	1606 – 2141	M30	46
M33	1806 – 2408	2449 – 3265	M33	
M36	2075 – 2767	2814 – 3752	M36	55
M39	3047 – 4062	4131 – 5508	M39	

*1: Torque for threaded parts that are clean, free of rust and contamination, and are well lubricated with 30 weight motor oil.

*2: Torque for threaded parts that are clean, free of rust and contamination, and dry.

NOTE

All plated (yellow galvanized) bolts are to use the *1 (lubricated) columns for torque wrench setting and hydraulic torque wrench settings. You may clean the threads but do not apply the actual lubricant. The plating is the lubricant.

MAINTENANCE

4.14.11 Checking Slew Device for Wear

During the many years of operation, the wear of the raceway system, and consequently the backlash of the slewing device increases.



If an increase of the backlash or advanced wear is suspected, please contact Tadano Mantis Customer Support personnel.

4.15 WINCHES



- ❖ **Perform work on the winch or on the auxiliary winch only when the crane is stopped and in no-load condition.**
- ❖ **Before beginning the work, take precautions to prevent unintended startup. Before starting the crane after maintenance or repairs, make sure that there is no one within the danger zone.**

4.15.1 Checking Winch Oil Level

1. Check the gear oil level every 1000 operating hours or six months, whichever occurs first.
2. To check the oil level, remove the plug located in the drum support. The oil should be level with the bottom of this opening. If additional oil is needed, refer to “Capacities & Specifications” table at the end of the maintenance section of this manual.

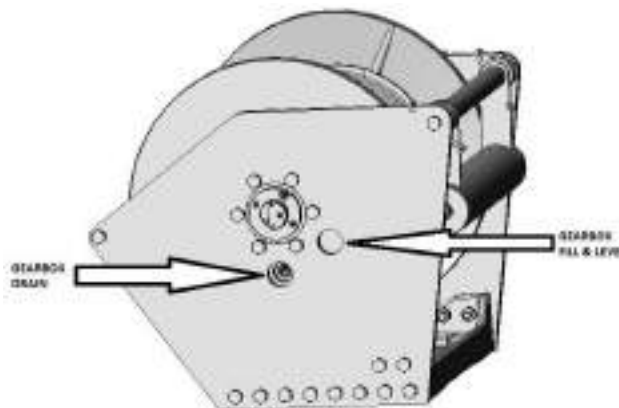

4.15.2 Changing Winch Oil

1. Perform the oil change at regular intervals according to the maintenance plan. Do not perform the oil change until the system has reached operating temperature.



Risk of scalding.

NOTE

◆ Check oil for foreign matter whenever an oil change is performed. Drain oil when the hydraulic system has reached normal operating temperature. If coarse impurities are detected, they may be due to excessive stress or improper operation. Determine the cause and eliminate it.

Dismantle the hoisting gear, check it for damage. If necessary, have the manufacturer perform a general overhaul. Check oil for possible blackening and foreign matter; if necessary, reduce oil change intervals.

2. Change the gear oil after the first one hundred hours of operation, then every 1,000 operating hours or six months, whichever occurs first.

MAINTENANCE

3. Change the gear oil to remove wear particles that impede the reliable and safe operation of the brake clutch and erode bearings, gears and seals. Failure to change gear oil at these suggested minimum intervals may contribute to intermittent brake slippage, which could result in property damage, severe personal injury or death.
4. Also change the gear oil whenever the ambient temperature changes significantly and an oil from a different temperature range would be more appropriate. Oil viscosity with regard to ambient temperature is critical to reliable brake clutch operation. Our tests indicate that excessively heavy or thick gear oil may contribute to intermittent brake clutch slippage. Make certain that the gear oil viscosity used in your winch is correct for your prevailing ambient temperature. Failure to use the proper type and viscosity of planetary gear oil may contribute to brake clutch slippage, which could result in property damage, severe personal injury or death. Refer to "Capacities & Specifications" table at the end of the maintenance section of this manual for additional information.



Different oil types—even if from the same manufacturer—must not be mixed. Mineral and synthetic oil also must not be mixed.

5. The vent plug is located in the drum support as shown. It is very important to keep this vent clean and unobstructed. Whenever gear oil is changed, remove vent plug, clean in solvent and reinstall. Do not paint over the vent or replace with a solid plug.
6. Procedure for changing gearbox and brake oil:
 - a. Gearbox oil is drained by first removing the drain plug (Item 33) by rotating the drum so that the plug is visible through the lower hole in the side plate (See Fig 1). Screw in a piece of 1" pipe to allow the oil to drain, and then with a hex wrench remove the drain plug located inside of the 1" pipe (See Fig. 2). Examine the used oil for signs of significant metal deposits and then dispose of it in a proper manner. Remove the 1" pipe.
 - b. Rotate the drum so that the port is visible through the upper hole in the side plate. With a hex wrench, remove the fill plug (Item 33) located in the center of the output shaft. Install a 1" pipe with elbow through the hole in the output shaft. Fill the gearbox with 1.00 quart of EP-90 oil according to the expected ambient temperature range. From -10°F to 130°F (-23° to 54°C), SAE 90W AGMA 4 EP is recommended. From -40°F to 110°F (-40° to 43°C), MOBIL SHC 75W90 is recommended. Remove the pipe and elbow then replace the plugs.
 - c. Drain the brake section by removing the drain plug (Item 40) under the motor along with the vent (Item 31) above the motor (See Fig. 4). Inspect the oil for signs of metallic particles and/or burning and reinstall the drain plug. Fill with ¼ quart of non-EP oil according to the expected ambient temperature range. From -10°F to 130°F (-23° to 54°C), SAE 20W20 is recommended. From -40°F to 110°F (-40° to 43°C), either MOBIL 1 SYNTHETIC ATF or MOBILE SHC 524 is recommended. Reinstall the vent (Item 31).

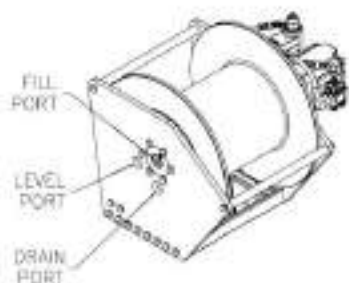

FIG 1

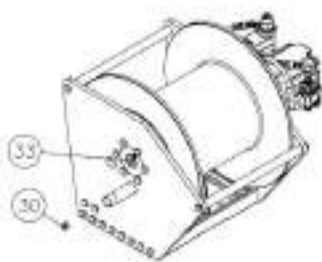

FIG 2



FIG 3

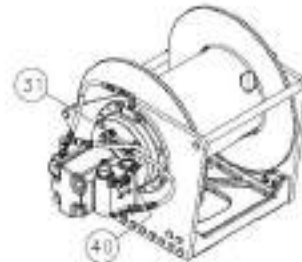

FIG 4

MAINTENANCE

4.15.3 De-commissioning the Winch

If the machine is to be decommissioned for an extended time, preservation of the winch is recommended. Drain the used oil and pour in half the quantity of preservative oil.

- Actuate the hoisting gear for approximately five to ten minutes, winding and unwinding the rope without load, using a high number of rope falls.
- On re-commissioning the machine, drain the preservative oil and pour in the specified oil type.
- Only such types of preservative oil may be used as emulsify with the lubricating oil, according to the oil manufacturer's specifications (use the recommended oil types).

4.15.4 Inspecting the Winch Brake

Check the winch brake for wear once per year. The hydraulic multi-disc brake of the hoisting gear is subject to a certain wear. For inspection, unscrew the hoisting gear flange together with the engine. In case of wear, replace the complete set of brake discs. At the same time, check the freewheeling (if equipped) of the winch brake.

To this effect, proceed as follows:

To check the freewheeling, pick up a load that amounts to 125% of the maximum rope pull force via the boom elevation using the short boom, and suspend it just above the ground. The distance that now exists between the lifted load and the ground must not change within fifteen minutes.

However, it must be taken into consideration that the angle included by the boom elevation cylinder does not change due to temperature influences. If the load moves down, replace the freewheeling.

4.16 ANTI-TWO BLOCK (A2B) SWITCH

The winch functions employ an RCI/A2B operator aid to prevent a "two-block" situation. When the load block or overhaul ball trips the anti-two-block switch, the switch actuates a solenoid valve, which blocks control (pilot) pressure to the function.

The boom down, boom telescope out, and boom lower functions employ the RCI/A2B operator aid to prevent a "two-block" situation. When the load block or overhaul ball trips the anti-two-block switch, the switch actuates a solenoid valve, which blocks control (pilot) pressure to the function.

The auxiliary winch also employs an RCI/A2B operator aid, in the "raise" direction, to aid the operator in preventing a two blocking situation when the weight at the boom, standoff, extension or jib tip is raised by the hook block or overhaul ball.

- Lift the bottom block carefully, until the releasing weight is lifted and trips the limit switch. When the limit switch is tripped, the boom down, boom telescope extend, and winch up functions should be deactivated.
- Lower the bottom block until the releasing weight is suspended freely; now all crane movements are possible again.

MAINTENANCE

4.17 TRAVEL SYSTEM

4.17.1 Track Drive Reducers

- The track drive reducer should be checked for any obvious signs of leakage before startup.
- Check oil level every fifty hours in accordance with the maintenance schedule.
- Change the oil in the track drive reducer every 1000 hours in accordance with the maintenance schedule.
- For additional information on lubricant types and quantities, refer to the capacities and specifications table.
- The track drive lubricant should be flush with the filler plug (1). If not, add oil to this level.
- Refer to capacities and specifications table. If leakage is found or any other damage is suspected, immediately check oil level in order to avoid damages to the mechanical parts. Loosen and remove the drain plug for oil draining (2).

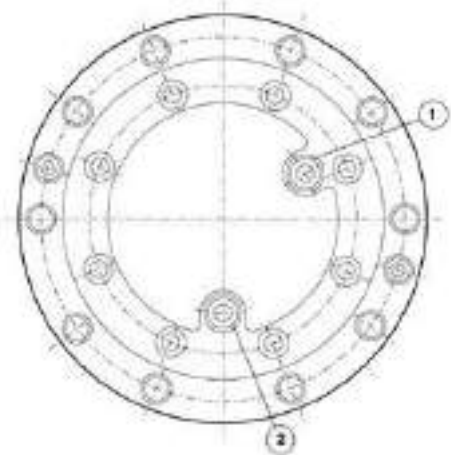

4.17.2 Track Tension

Track tension should be checked weekly and corrected as necessary.

4.17.3 Extend Beams

Extend beams should be cleaned and re-greased weekly to prevent excessive wear. Remove all debris and re-grease extend beams in accordance with maintenance schedule.

4.17.4 Undercarriage

Inspect undercarriage for any premature wear or damage in accordance with maintenance schedule. See lubricant specifications for information on track roller and idler lubrication. Contact Tadano Mantis Customer Support with questions or concerns.

MAINTENANCE

4.18 LAST WRAP INDICATOR

The last wrap indicator should be set to ensure a minimum of five wraps of cable on the drum.

- Extend the boom and wind off the rope until at least **five** rope windings remain on the drum.
- When the winch unwinds to the fourth wrap, activating the limit switch, the winch function must shut off.
- In order to remove the rope, use the last wrap indicator override switch located on the rocker switch panel in the operator cab.
- Before winding up the rope, check the rope drum for wear. While spooling up, check the rope for damage and if necessary, grease it.
- See Appendix B (Drum Rotation & Last Layer Indicator) for detailed information on resetting the shutdown point.



If the last wrap indicator is not properly set, there will not be a warning when the limit is approached, and the function will not be blocked when the limit is reached. The operator is responsible for verifying the warning and shutdown are working properly. Failure to comply may result in serious injury, death, and/or equipment damage.

4.19 WINCH ROPE

NOTE

◆The winch rope servicing and maintenance operations must be performed for both the main and auxiliary winches.

4.19.1 Inspecting the Rope

The rope must be checked visually before and after each application.

- Ropes must be discarded if one of the following deficiencies occurs: breakage of a rope, breakage of a strand, stepping up, bruising, traces of corrosion, wear, reduction of the rope diameter, lasting deformation, etc.
- The ropes must be checked along their whole length, even at the fastening devices.

4.19.2 Cleaning and Lubrication of the Rope

To prolong the service life of the ropes, wash severely soiled ropes down with clear water at regular intervals, and grease them after drying. To protect the ropes against humidity and corrosion, grease them at regular intervals using adhesive grease.

- It is not sufficient to grease the rope only on the outside. The lubricant must penetrate into the rope.
- Use the recommended types of lubricants.

NOTE

◆To increase the rope's service life, keep it tidy; do not drag it over the ground.

4.19.3 Replacing Rope

1. Place the bottom block on the ground.
2. Detach the rope socket from its bolt-fastening devices and remove it.

MAINTENANCE

3. Remove the winch rope from the hoist limit switch weight and detach the rope falls from the bottom block and the guide pulleys.
4. Wind off the winch rope until the rope limit switch shuts off.
5. Loosen the residual rope windings.
6. Detach the rope end by hammering the rope key (1) out of the drum; remove the winch rope.

4.19.4 Inspecting Rope Drum

Before placing a new rope of the same type (refer to crane inspection booklet), check the rope drum.

- Clean the drum thoroughly, removing dirt, old paint and foreign matter.
- Check the rope drum grooves for wear.
- If necessary, perform an oil level inspection via the inspection plug.

4.19.5 Installing New Rope

NOTE

◆The service life of a rope depends essentially on the way how it is handled on positioning. For replacement, make sure that only metallic ropes of the same type, strength and diameter are used.

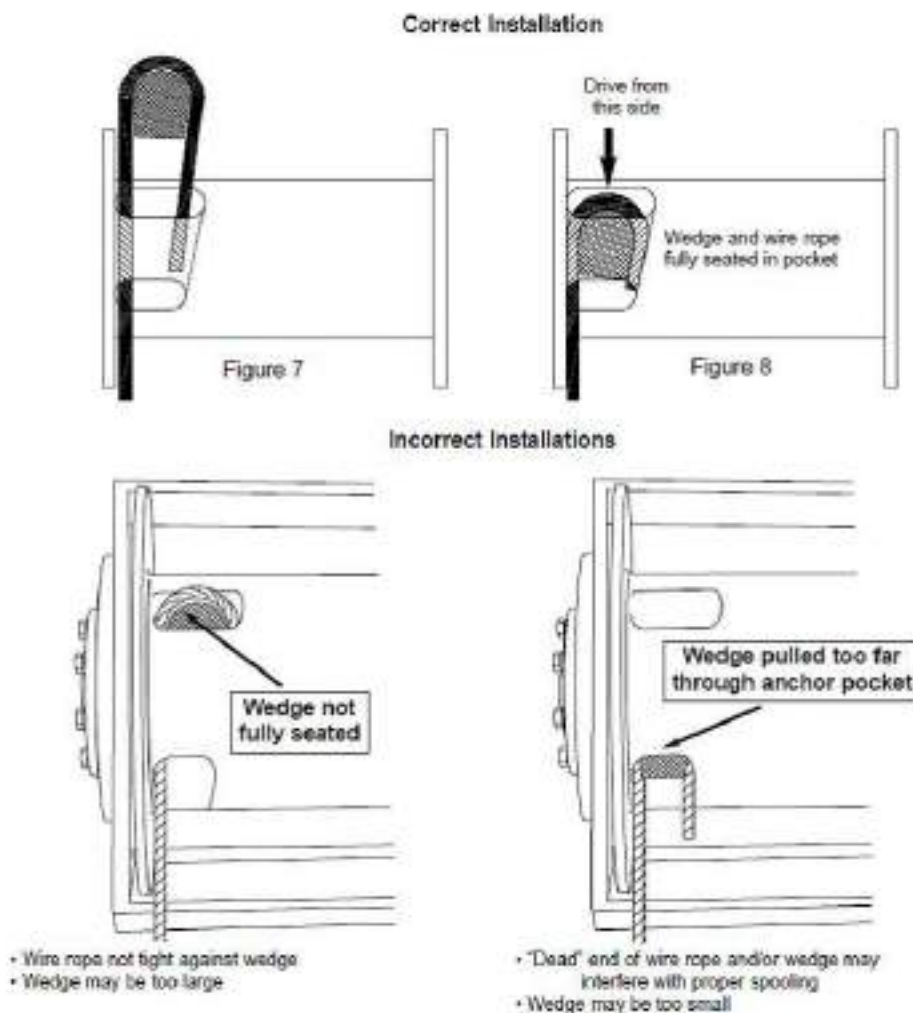

MAINTENANCE

1. If possible, place a reel stand below the boom head when performing this work.
2. The rope is only wound up properly on the drum when the correct turn directions are selected.
3. When winding up the rope, make sure that it is under tight tension (if necessary, grease the rope).
4. Route the rope through the weight in the hoist limit switch, reeve the various rope falls in the bottom block, and fasten the rope to the rope socket.

NOTE

◆Initially, the new rope may only be moved under moderate load and the load must be increased gradually to its maximum rating, so that the rope is allowed to run in, to settle, and to lengthen.

4.19.6 Winch Rope Care

- Regular care to the rope helps ensure safety during crane operation and is essential for enhancing the rope's service life considerably.
- Re-grease metallic ropes at regular intervals, depending on the operating conditions (especially important in the bending areas at the drum and the pulleys). The agents used for re-greasing must be compatible with the original rope lubrication.
- Under identical test conditions, well-greased ropes provide four times the fatigue strength under reversed bending stress than non-greased ropes.
- Metallic ropes that are subject to severe dirt accumulation should be cleaned at regular intervals, best done using a brush and washing with clear water.
- If the lower rope layers on the drum are nearly not used or not used at all, unwind them from time to time and re-position under pre-load. A rope will operate with optimum economic efficiency if its entire length is always used. Therefore, it is recommended to use a rope length suitable for the work to be performed if crane operation will take an extended period of time.
- Check the rope visually at regular intervals, especially during the first time after placing. Check it also after extraordinary stress, in case of supposed, but not visible damage, or if there are first signs of damage at the rope.
- If the same hoisting movement is executed frequently, the winch rope may be dislocated longitudinally from time to time.

4.20 CRANE CABIN

Grease joints, pins, and all movable components with lubricating oil. Make sure that these parts move unrestrictedly and are easy to operate.

The mechanical components of the door lock also require regular care. Treat the closing cylinder with a graphite agent, preferably before the cold season begins. It is most useful to treat door seals and other rubber components with acid-free grease or French talc before the cold season begins.

4.20.1 Heat, Ventilation, & Air Conditioning

Any work on the heating, ventilation, and air conditioning system must only be performed in an authorized workshop by qualified personnel.

NOTE

◆Work on the air conditioner requires specific extraction and filling stations, recovery stations, electronic leak detectors, and special tools only available in specialist workshops. Correct disposal of fluids is also only ensured in a specialized workshop.

MAINTENANCE

4.20.2 Air Intake Filter

The intake air filter for the fan and the air conditioning is located on the left exterior wall of the crane cab. If the air filter is visibly clogged by relatively big particles, it must be replaced. The replacement intervals depend greatly on the crane's application. The filter is a disposable pleated paper filter and must not be washed. Do not use compressed air to clean the filter.

4.20.3 Wiper-blade Elements/Washing System

Clean the wiper-blade elements at regular intervals to work properly. For safety reasons (good visibility), it is recommended to replace the wiper-blade elements immediately if their cleaning effect decreases. Replace the wiper-blade elements at least once per year.

The tank of the windshield washing system is located inside the crane cabin behind the seat.

4.21 POINTS OF LUBRICATION, MAINTENANCE

4.21.1 Boom

- Grease the boom head sheaves, bearing pads, and boom hoist cylinder pins at regular intervals, according to the maintenance schedule (use recommended grease types).
- When greasing the boom, also apply grease to the extend sheave bearings on the inside of the boom. The second, third, and fourth stages of the boom have access holes to allow for lubrication of the extend heave. Extend the boom until holes in the second, third, and fourth stages are aligned. Apply grease at regular intervals, according to the maintenance schedule.
- Grease the basic boom bearings via the lubrication port on the left and right of the basic boom at regular intervals, according to the maintenance schedule.

NOTE

◆Whenever the crane has been cleaned, especially using a steam jet cleaning unit, check the lubrication of the boom bearing pads, etc. of the telescoping sections.

These components must always be provided with a sufficient lubrication.



When extending the boom to grease the telescoping sections the crane should be on firm and level ground. Also, full counterweight must be installed, tracks must be fully extended, and the boom angle must be set to 0°.

4.21.2 Boom Hoist Cylinder

Grease the top and bottom boom hoist cylinder pins at regular intervals, according to the maintenance schedule.

4.21.3 Hook Block

The hook block sheaves must be greased at regular intervals, according to the maintenance schedule. The lubricating intervals depend on the number of operating hours and the operating conditions; under extreme conditions, lubrication may have to be effected earlier than specified in the maintenance schedule.



Do not weld on any components of the hook block.

MAINTENANCE

4.21.4 Jib and Extensions

Grease all lubrication points according to the maintenance schedule. Adjust lubrication intervals as necessary.

4.21.5 Other Points of Lubrication

Grease joints, pins and all movable components, such as: slew ring race, slew ring teeth, track tensioning idler, extend beams, etc.

4.22 LUBRICATION AND FILTER SPECIFICATIONS

NOTE

◆The filling capacities specified below are approximate values. For precise measuring results, the oil level inspection plugs, the oil dipsticks or inspection glasses are always decisive. Only those qualities may be used which are listed in the chart of approved consumables of the assembly manufacturer, or which indicated on the nameplate of the assemblies.

4.22.1 Lubrication Specification Table

			REV. 12/16/2013
Equipment	Material	Capacity/Quantity	Comments
Auxiliary Generator -Lube Oil -Fuel Tank	Optional feature Same as engine Same source as engine	0.8 liters (0.85 US qt.)	Same source as engine
Auger Motor*	GL-5 EP SAE 80/90	4.7 liters (5 US qt.)	Esckridge Model 74
Batteries	Distilled Water	Fill to 'split rings' under caps	All Cranes
Boom Bearing Pads	EP 2	As required	All Cranes
Boom Cylinder Pin	EP 2	Until 'new' grease is visible	All Cranes
Boom Foot Pin	EP 2	Until 'new' grease is visible	All Cranes
Boom Sheaves	Shell Alvania EP2 or equivalent	Until 'new' grease is visible	All Cranes
Diesel Fuel Tank	No. 1 or No. 2 Diesel	398 liters (105 US gallons) 302 liters (80 US gallons) 208 liters (55 US gallons) 757 liters (200 US gallons)	14010 6010, 8012, 9010, 10010Mx 3612 200RS
Engine, Cooling System	Water/Anti-Freeze Mix	24.2 liters (26.7 US qt.) 18.9 liters (20 US qt.) 26.5 liters (28 US qt.) 59 liters (62 US qt.)	Caterpillar 3116 & Cummins B5.9 Cummins 8.3C Cummins QSB Cummins QSX-15
Engine, Lube Oil	API: CF/SG & CH 4/SJ 15w/40	18.5 liters (19.5 US qt) 15.0 liters (16 US qt) 23.8 liters (25.2 US qt.) 83.25 liters (88 US qt.)	Deutz BF6L Caterpillar 3116, Cummins B5.9 & QSB Cummins 6C 8.3 Cummins QSX-15
Hydraulic Tank	Shell Tellus T-32	567 liters (150 US gallons) 1135 liters (300 US gallons) 1704 liters (450 US gallons)	3612 & 6010 8012,9010, 10010MX, 14010 200RS
Slew Ring Race	Shell Alvania EP2 or equivalent	As required	Grease while rotating until new grease becomes visible at the seal
Slew Ring Teeth	Texaco 'Crater' 2X or 5X	Coat teeth at each greasing	All Cranes
Swing Brake	Shell Tellus T-32	0.37 liters (0.39 US qt.) 0.33 liters (0.34 US qt.) 0.39 liters (0.41 US qt.)	3612/6010 8012,9010,10010MX,15010,200RS 20010
Swing Drive Reducer	EP 90	Fill to 4.5 cm (1.75 inches) below the outside of housing fill/check plug (minimum)	All Cranes
Track Drive Reducers	EP 90	4.7 liters (5 US qt.) 6 liters (6.4 US qt) 6.8 liters (7.5 US qt.) 6.8 liters (7.5 US qt.) 13.5 liters (14.25 US qt.) 11 liters (11.6 US qt.)	3612/6010 (KYB) 10010, 12010, 14010 (Linde GK 80) 6610, 8010, 8012 (KYB) 8012, 9010, 10010MX, 14010 (BonTras) 200RS (O&K) 20010 (O&K)
Track Idlers	SAE 40W	0.45 kg (0.99 lbs)	All Crawler Cranes
Track Rollers**	SAE 40W	0.23 liters (0.24 US qt)	All Crawler Cranes
Track Tension	Shell Alvania EP2 or equivalent	As required	See Maintenance chart for adjustment procedure
Winch, Carbody	Texaco Meropa (-20F to 80F) Mobil SCH 630 Synthetic	15 liters (16 US qt)	200RS
Winch, Braden	Texaco Meropa (-20F to 80F) Mobil SCH 630 Synthetic	PD17A: 6.62 liters (7 US qt) CH 400A: 31.25 liter (33 US qt)	15010 200RS
Winch, TWG Gearbox	EP90	1241W: 0.95 liters (1 US qt) 1541W: 2.36 liters (2.5 US qt)	3612/6010 8012,9010,10010MX
Winch, TWG Brake	Lightweight Non EP	1241W: 0.23 liters (0.25 US qt) 1541W: 0.23 liters (0.25 US qt)	3612/6010 8012,9010,10010MX
Winch, Lantec	Texaco Meropa (-20F to 80F) Mobil SCH 630 Synthetic	LHS160: 25 liters (26 US qt) LHS240: 32 liters (34 US qt)	20010
Winch, w/Freefall	Texaco Meropa (-20F to 80F) Mobil SCH 630 Synthetic	G2H30: 'Fill to Plug'	10010,12010, 14010 (optional aux winch)

*Test level w/fill plug removed, maximum level: No overflow from fill hole @ 40 degree tilt above horizontal axis; minimum level: overflow from fill hole @ 10 degree above horizontal axis.

** Measure to middle of primary planet gears when the auger is in the vertical position. Tilt back slightly when filling through oil fill hole to achieve proper capacity.

4.22.2 Filter Specification Table

10010MX FILTER SPECIFICATIONS equipped with Cummins QSB		
	Manufacturer	P/N
Lubricating Oil	Fleetguard	LF 3970
Fuel	Fleetguard	FF5612
Fuel/Water Separator	Fleetguard	FS19732
Engine Air	Farr	T-519
Cooling System (Precharge)	N/A	N/A
Hydraulic Return	Schroeder	124085
Hydraulic Pilot Oil	HYDAC	02060902

4.22.3 Inspection Scheme (Daily, Before Startup)

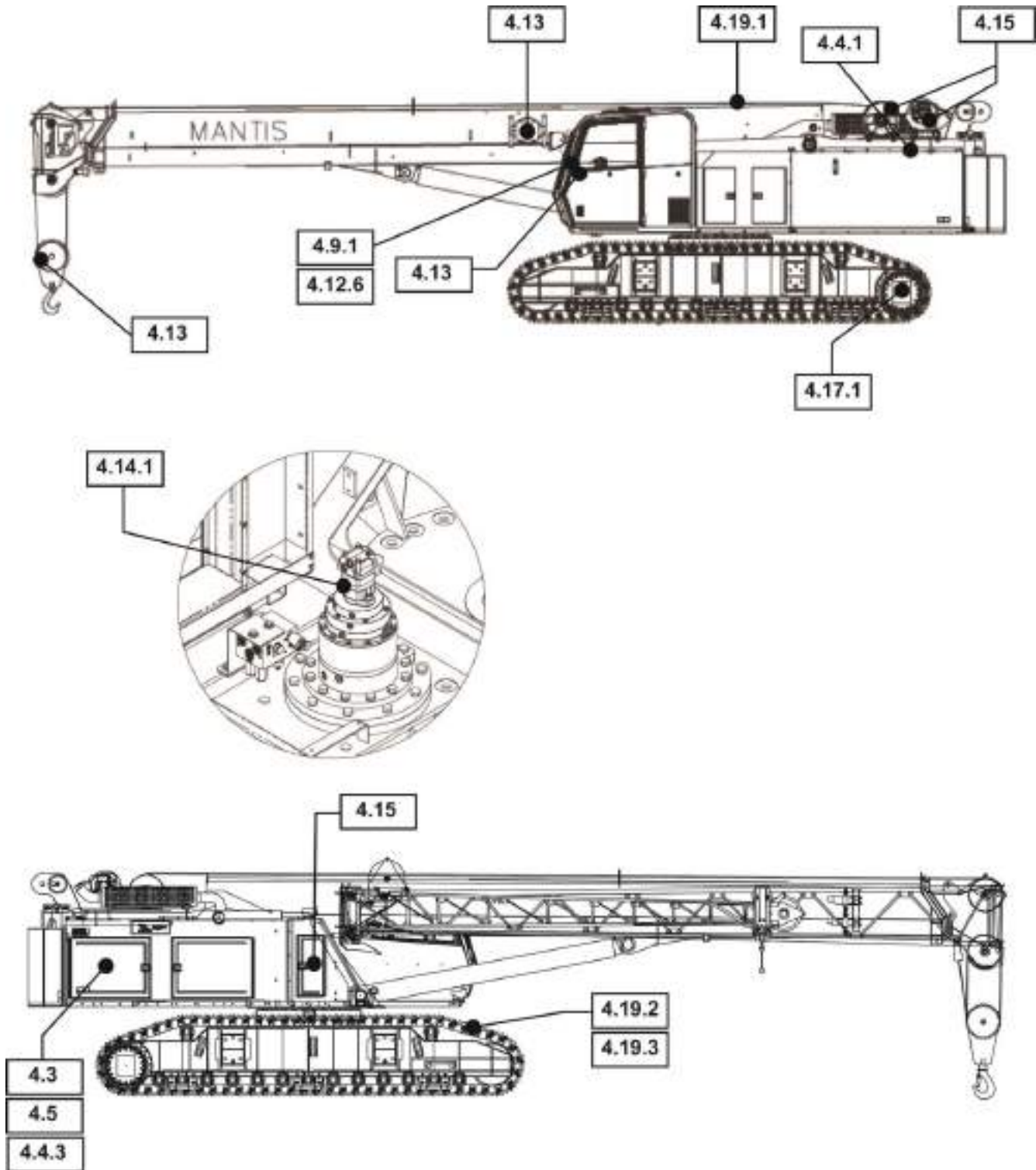

4.22.4 Oil / Coolant Level Inspection and Change Scheme

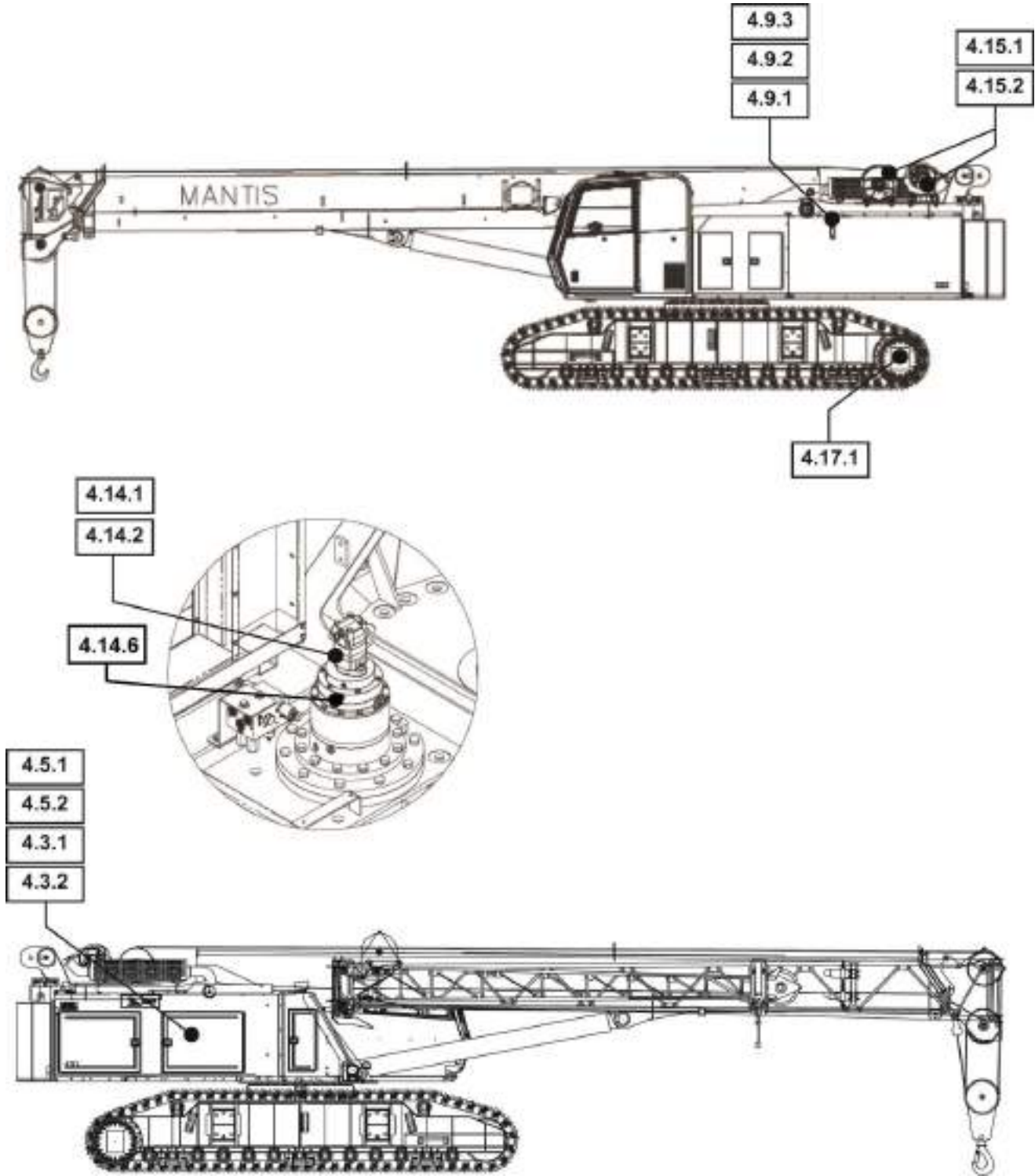

4.2.2.5 Inspection and Cleaning Scheme

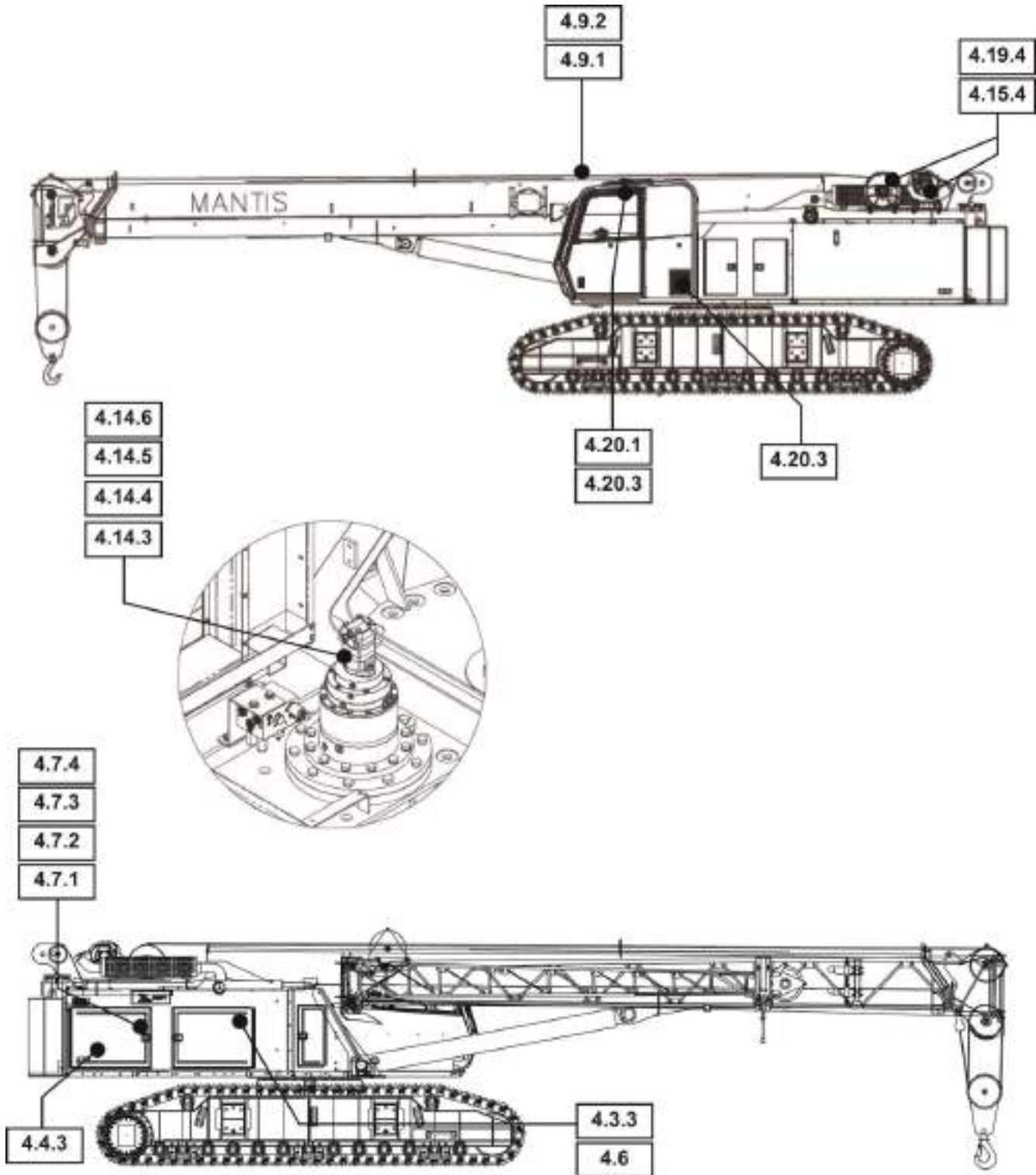

4.22.6 Lubricating Scheme

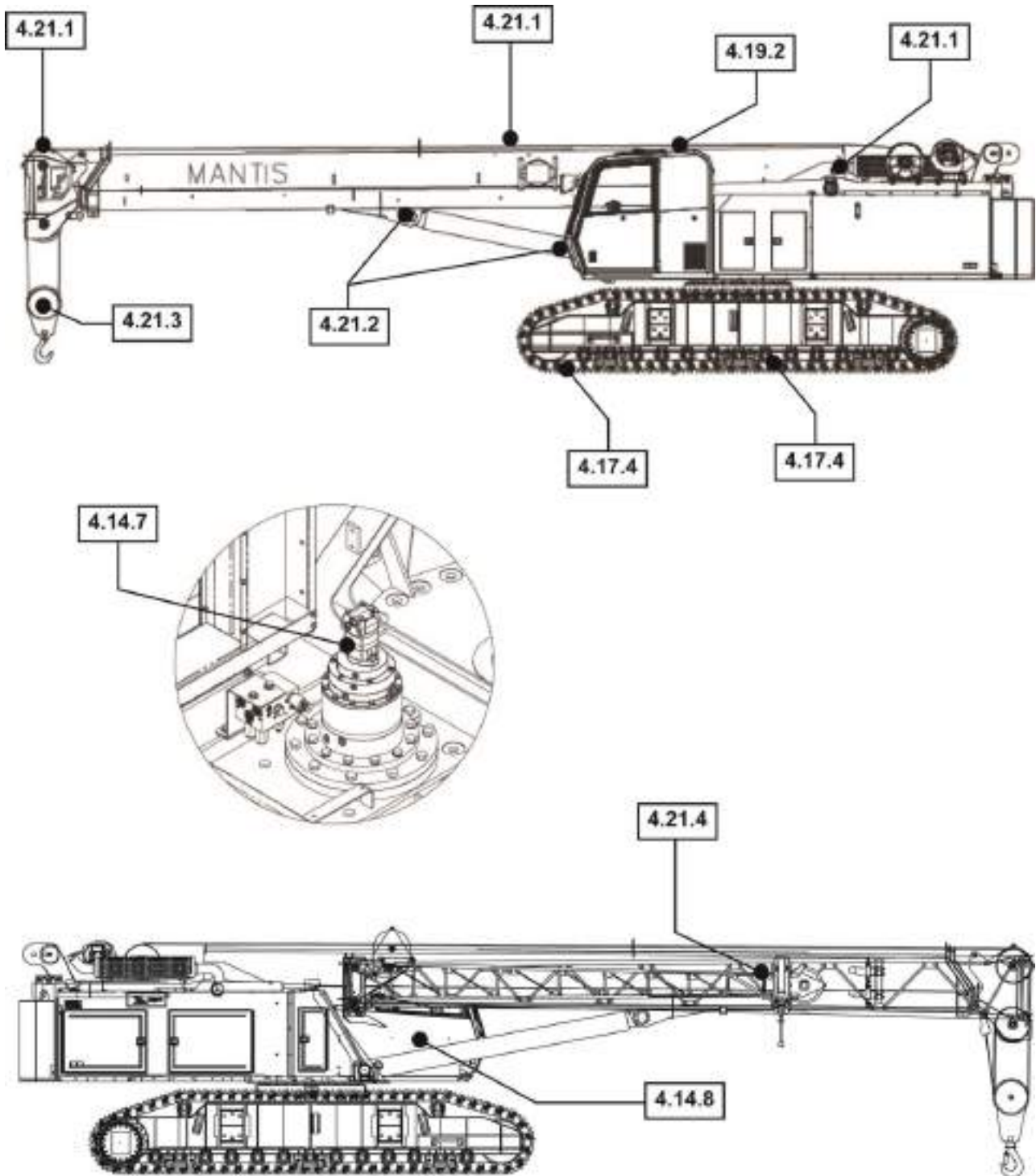

Appendix A

SECTION 5. APPENDIX A – LOAD MOMENT INDICATOR

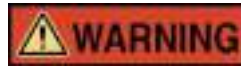

Never operate the crane with the automatic stop function of the load moment indicator canceled. If you use the load moment indicator incorrectly, the machine can overturn or suffer damage and cause a fatal injury.

5.1 GENERAL

The load moment indicator calculates the hook load and rated lifting capacity based on the operation configuration registered by the operator and input signal from each detector, and display them as a load ratio. When the load ratio reaches or exceeds 100%, the load moment indicator stops the crane operation toward the critical sides and warns with error codes and buzzer.

The load indicator is a safety device to prevent accidents such as machine overturning and damaged caused by overload, and it is not a load meter. The shown lifting loads are reference values and their precision is not guaranteed.

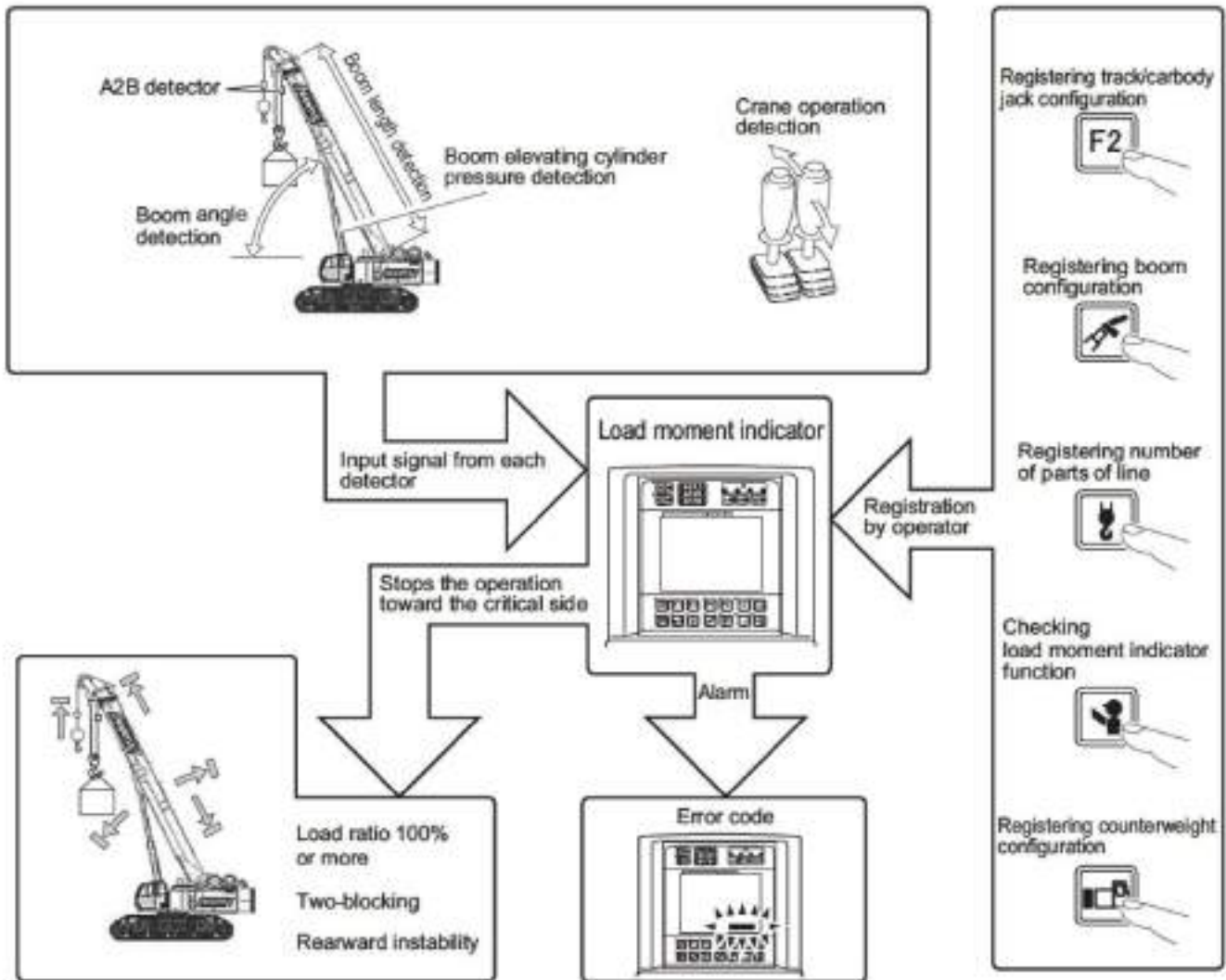

Appendix A

The load moment indicator consists of the LED display, display panel, and controls. The LED display shows the alarm condition of each working range limit and the condition of the load moment indicator function.

The display panel shows the load ratio, crane condition, track/carbody jack configuration and error code. Note the carbody jack is optional.

Load moment indicator

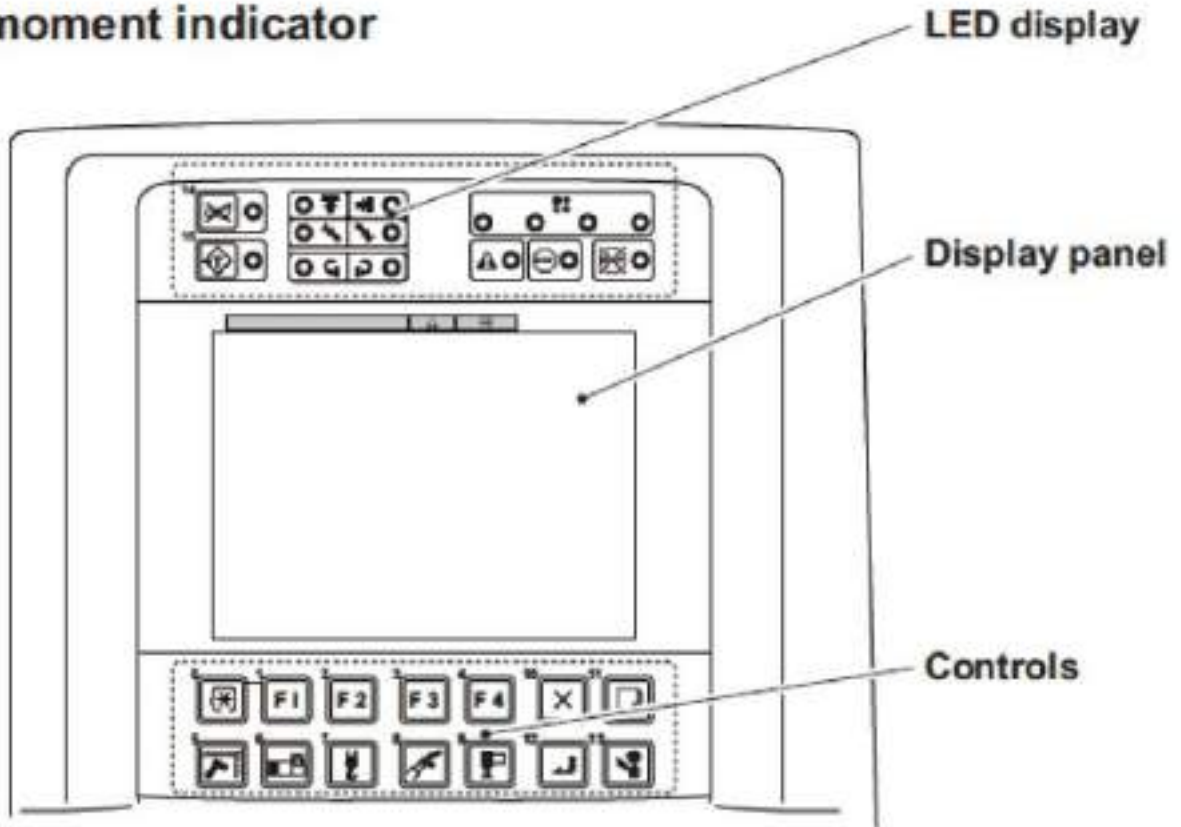

Display Panel

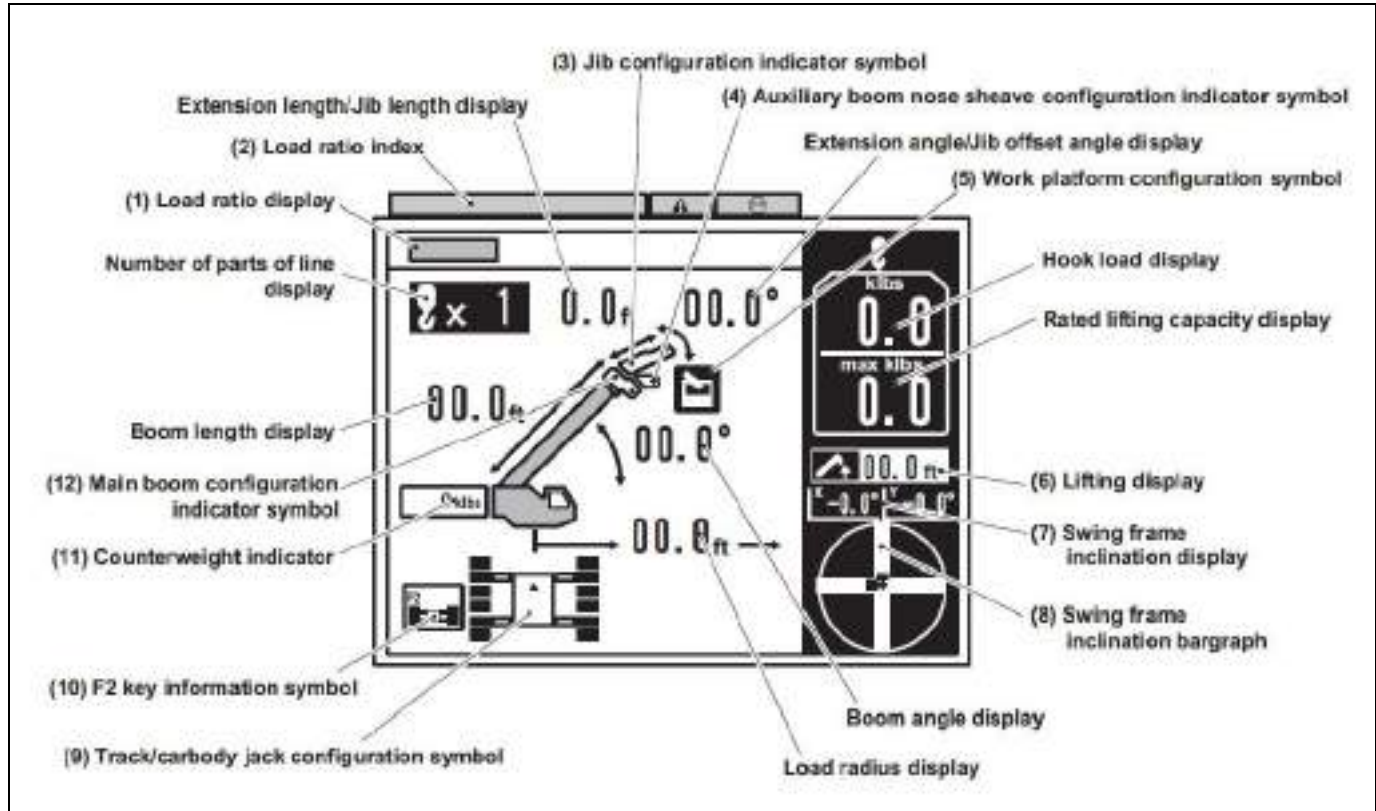

NOTE

◆The load moment indicator is not a load meter. The hook load indication is a reference value and not a correct mass of the lifted load.

- 1) Load Ratio Display
Shows the load ratio with a bar graph.
- 2) Load Ratio Index
Shows the load ratio index bar graph: Safe (green), Warning (yellow), or Critical (red).
- 3) Jib Configuration Indicator Symbol
Appears when the extension or the jib is registered.
- 4) Auxiliary Boom Nose Sheave Configuration Indicator Symbol
Appears when the auxiliary boom nose sheave is registered.
- 5) Work Platform Configuration Symbol
Appears when the use of a work platform is registered.
- 6) Lifting Height Display
Shows allowable maximum hook height off the ground in an actual crane setting for hoisting.

Appendix A

7) Swing Frame Inclination Display

Shows the inclination of the swing frame. The value in the "X" box shows the inclination in the right/left direction and the value in the "Y" box shows the inclination in the front/rear direction. When the left side is higher, it shows a positive value and when lower, it shows a negative value in the "X" box. When the back side is higher, it shows a positive value and when lower, it shows a negative value in the "Y" box.

8) Swing Frame Inclination Bar Graph

The bar graph shows the direction where the swing frame is lower.

9) Track/carbody Jack Configuration Symbol

Shows the track condition (extended or retracted) and carbody jack condition.

10) F2 Key Information Symbol

Indicates F2 key is used to register Track/Carbody Jack condition.

11) Counterweight Indicator

Shows the condition of mounted counterweight.

12) Main Boom Configuration Indicator Symbol

Appears when the main boom is registered.

LED Display

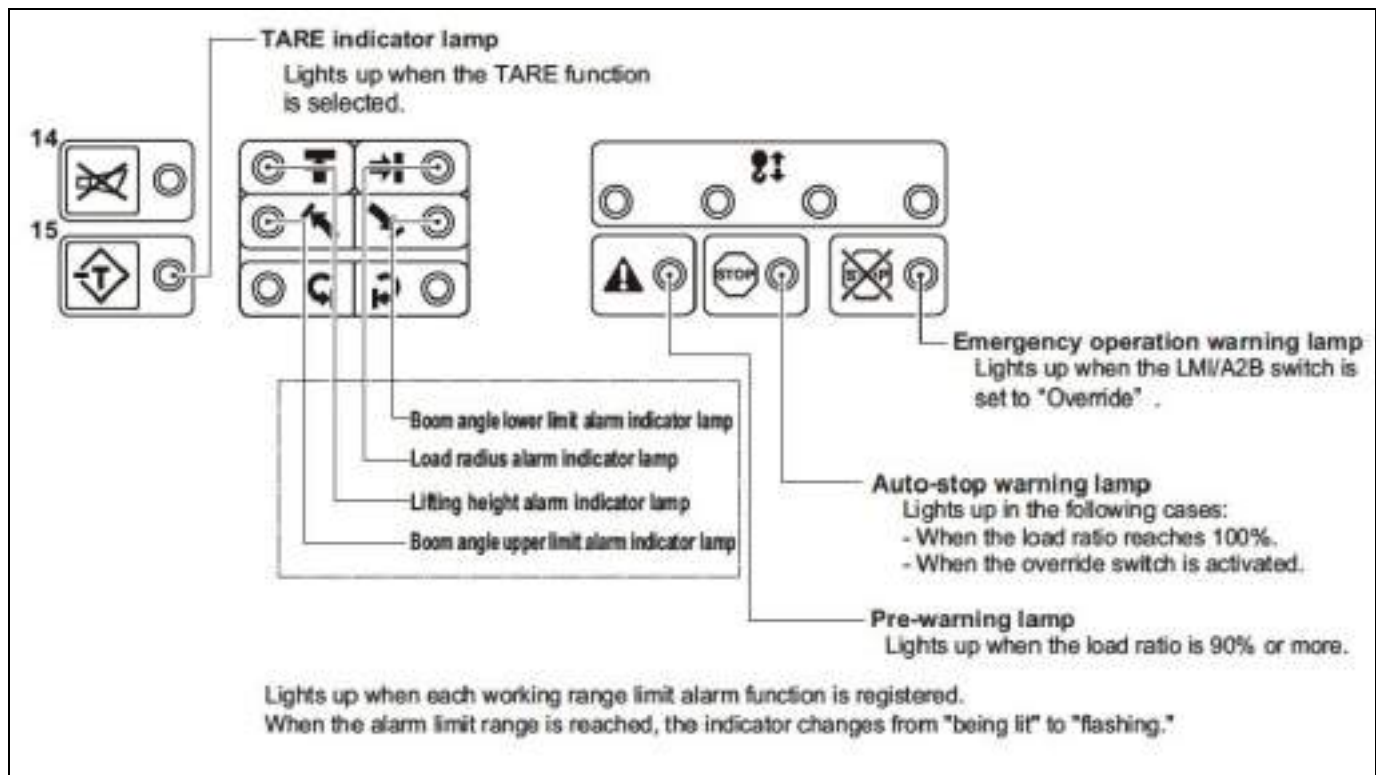

Controls

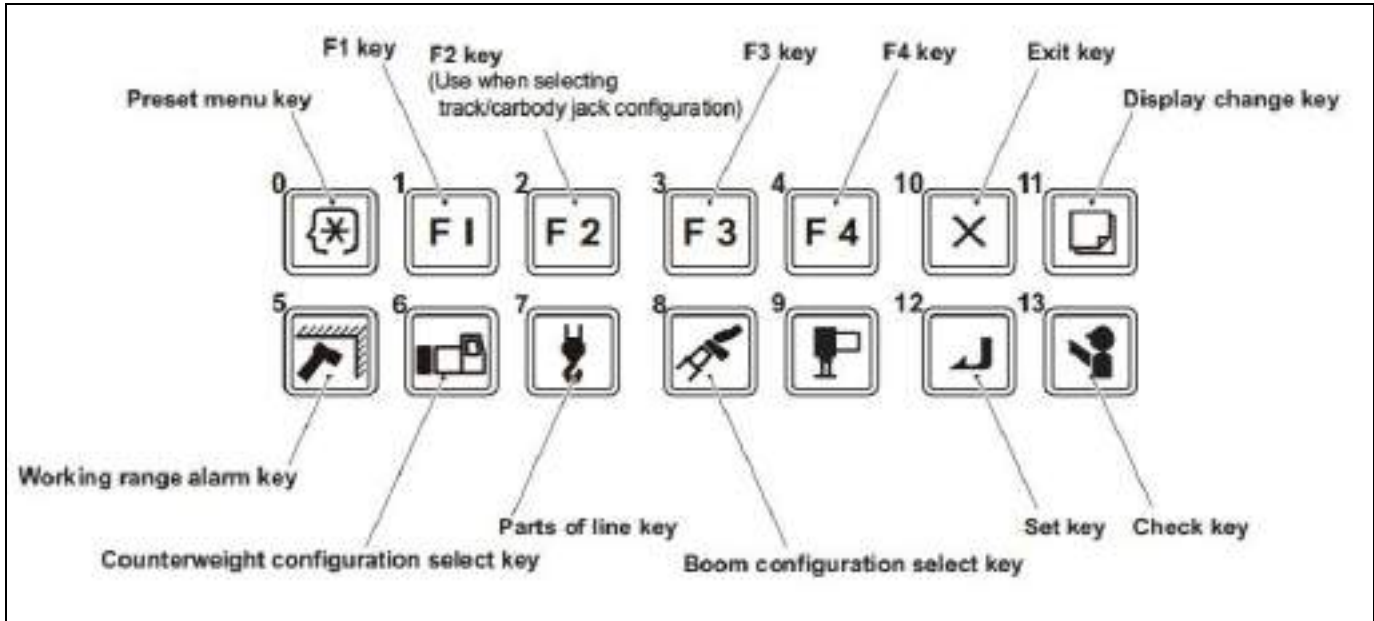

5.2 OPERATING STATUS REGISTRATION & LOAD MOMENT INDICATOR FUNCTION CHECK

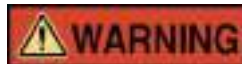

Before you start the crane operation, make sure that correct operation configuration is registered and the load moment indicator system functions normally. If you register the operation configuration incorrectly or the load moment indicator system does not function normally, the machine can overturn or suffer damage, and this can cause a fatal injury.

Before the crane operation, observe the steps below to register the operation condition and check the load moment indicator functions.

1. Start the engine.
 - The load moment indicator is turned on.
2. Push the counterweight configuration select key.
 - The pop-up window for counterweight configuration registration appears on the display panel.
 - Each time the counterweight configuration select key is pushed, the display changes as shown below.

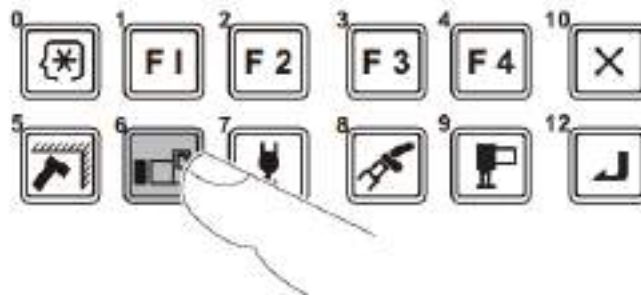

Appendix A

Pop-up window for counterweight configuration registration is displayed.

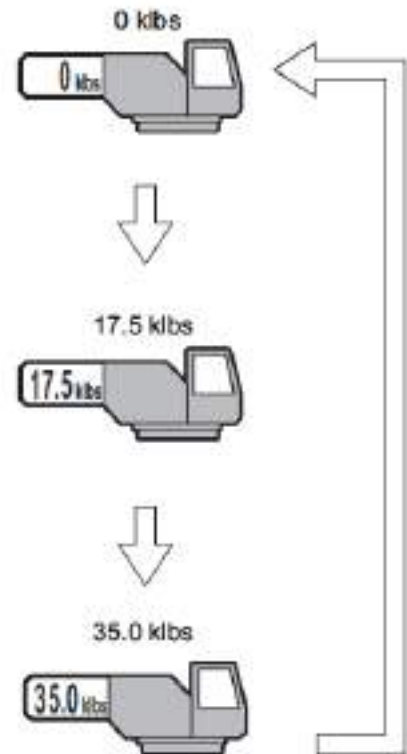
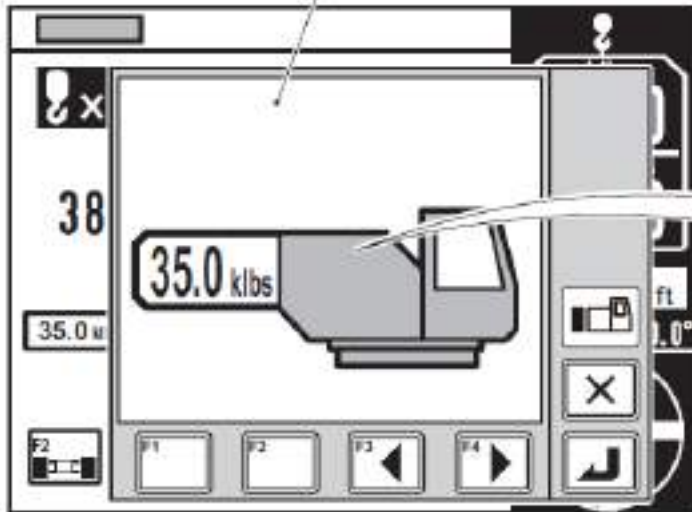

- When the power of the load moment indicator is turned on, the pop-up window for the counterweight configuration registration shows “0 klbs.”
 - Instead of the counterweight configuration select key, you can use the F3 (Backward) key or F4 (Forward) key to change the display of the counterweight configuration registration.
3. Make sure that the display agrees with the actual counterweight configuration.
- The meanings of the counterweight configuration symbols are as shown below.

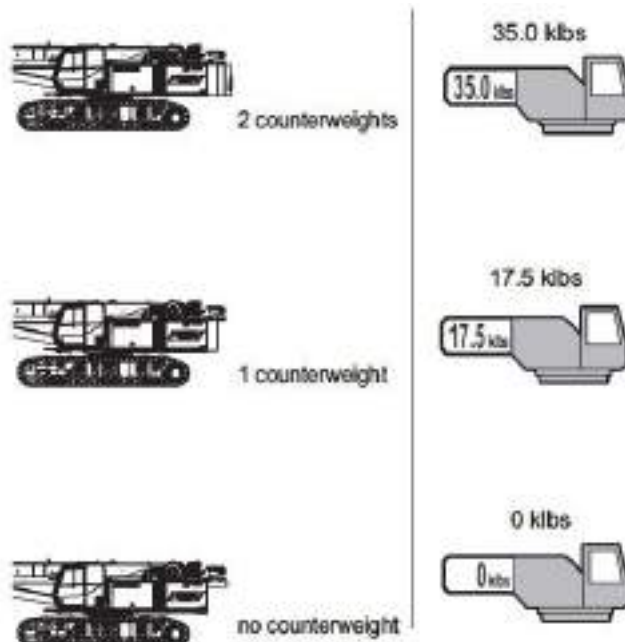

Appendix A

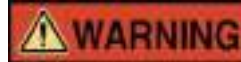

If the indication on the load moment indicator and actual counterweight configuration does not match, an overturning accident or crane damage can occur.

- When you want to stop registration, push the exit key. The pop-up window closes and the load moment indicator returns to the state before the start of the registration.

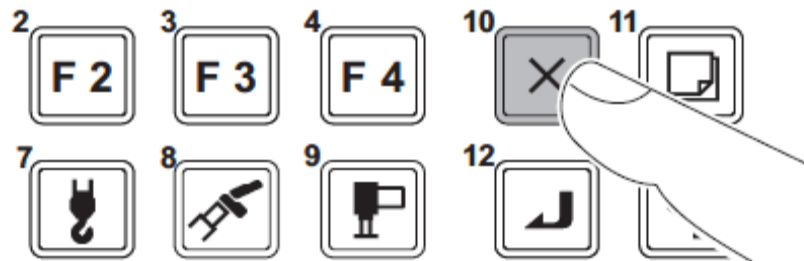

- If the display agrees with the actual condition, push the set key to register the configuration.

- After registration is completed, the pop-up window closes and the load moment indicator returns to the original screen.

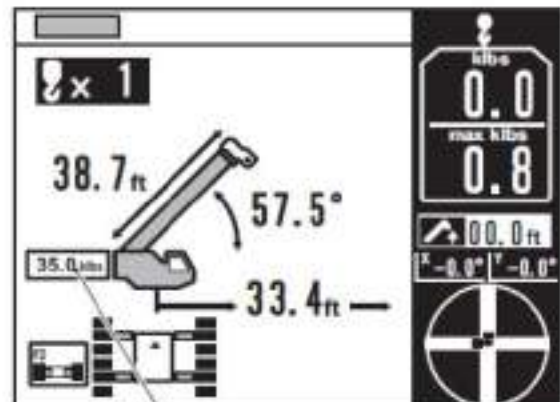
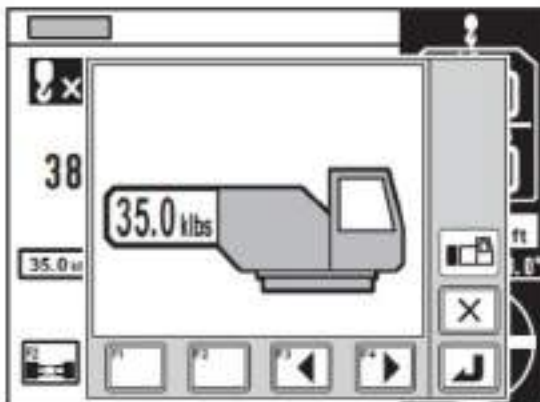
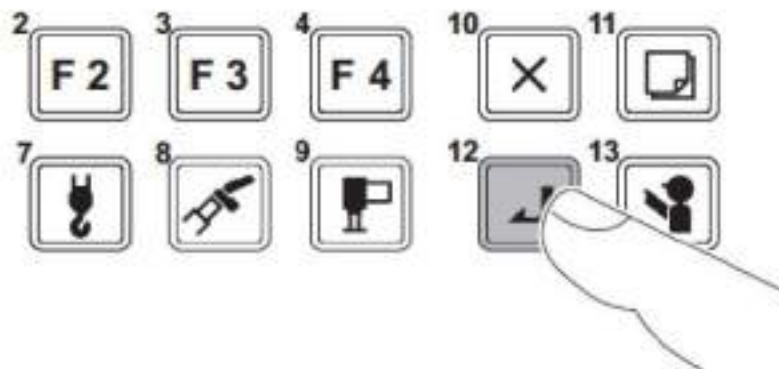

Registered counterweight configuration

Appendix A

5. Push the F2 key.

- The pop-up window for track/carbody jack configuration registration appears on the display panel. When you enter time the F2 key is pushed, the display changes as shown below.

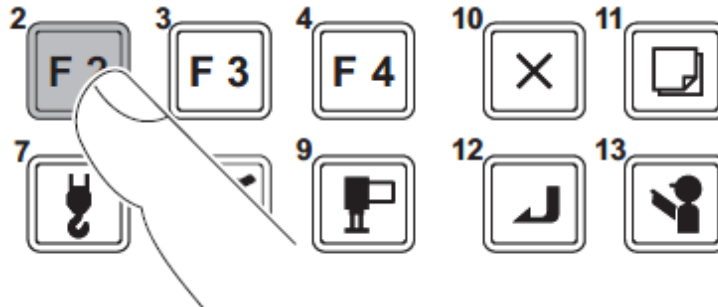

Pop-up window for track/carbody jack configuration registration is displayed.

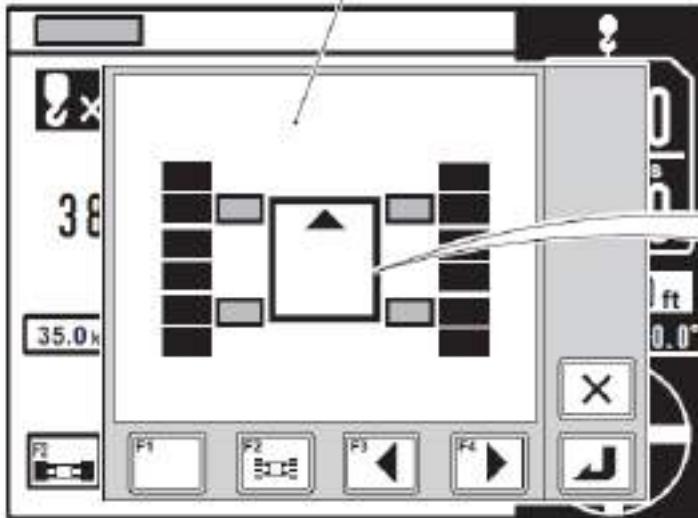

Carbody jack (Optional)

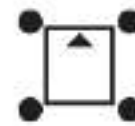

Track retracted

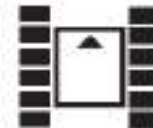

Track extended

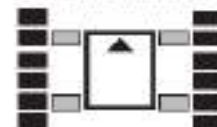

- When the load moment indicator is turned on, the configuration is selected automatically as follows:
 - When the carbody jacks (optional) are installed: "Carbody jack" configuration.
 - When the carbody jacks are not installed: "Track retracted" configuration.
- If the carbody jacks are not installed, the "Carbody jack" configuration does not appear on the display.
- Instead of the F2 key, you can use the F3 (Backward) key or F4 (Forward) key to change the display of track/carbody jack configuration.

6. Make sure that the display agrees with the actual track/carbody jack configuration.

- The meanings of the track/carbody jack configuration symbols are as shown below.

Appendix A

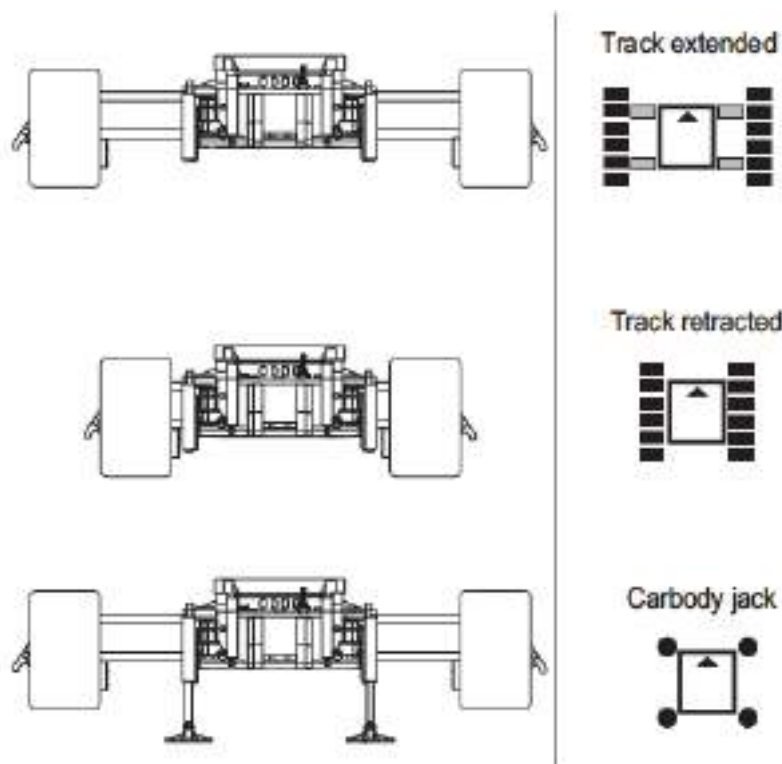

- When you want to abort registration, push the exit key. The pop-up window closes and the load moment indicator returns to the state before the start of the registration.
7. If the display agrees with the actual condition, push the set key to register the configuration.
 - After registration is completed, the pop-up window closes and the load moment indicator returns to the original screen.
 8. Install main or auxiliary hook blocks as needed for the intended application.



9. Push the boom configuration select key to register the boom configuration (boom/auxiliary boom nose sheave/extension/extension +jib/platform).
 - The pop-up window for the boom configuration registration appears on the display panel. Each time you push the boom configuration select key, the display changes as shown in the illustration below.

Appendix A

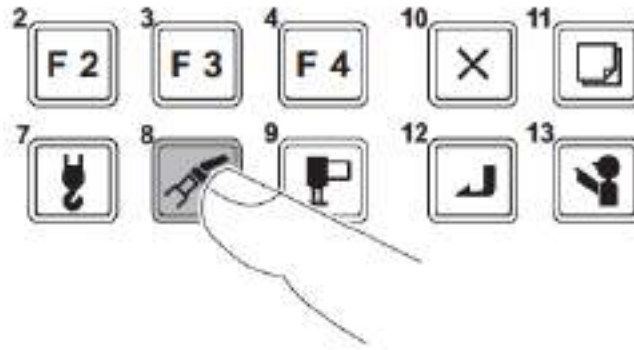

Pop-up window for boom configuration registration is displayed.



Pop-up window	Lift status
	Main boom
	Auxiliary boom nose sheave
	30.0 ft (9.1 m) extension 0.0' offset
	30.0 ft (9.1 m) extension +20.0 ft (6.1 m) jib jib 0.0' offset
	30.0 ft (9.1 m) extension +20.0 ft (6.1 m) jib jib 15.0' offset
	30.0 ft (9.1 m) extension +20.0 ft (6.1 m) jib jib 35.0' offset
	Work platform on main boom
	Work platform on 30.0 ft (9.1 m) extension

- When the power of the load moment indicator is turned on, main boom is initially selected.
 - Instead of the boom configuration select key, you can use the F3 (Backward) key or F4 (Forward) key to change the display of the boom configuration.
 - When you want to stop registration, push the exit key. The pop-up window closes and the load moment indicator returns to the state of the registration.
10. Push the set key to register the setting.
- After registration is completed, the pop-up window closes and the load moment indicator returns to the original screen.

Appendix A

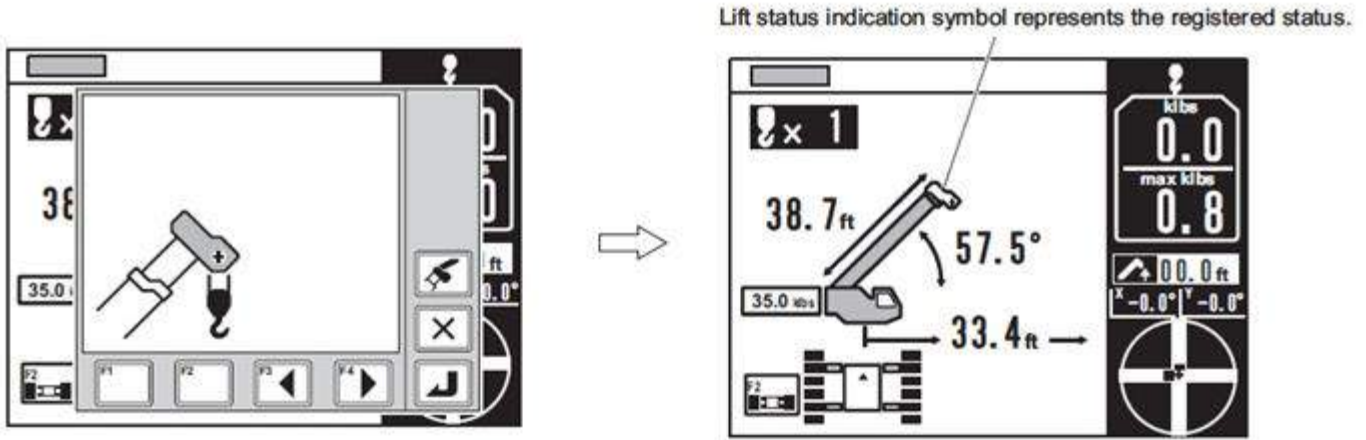

11. Push the parts of line key to register the number of parts of line to be used.

- The pop-up window for parts of line registration appears on the display panel. Each time you push the parts of line key, the number of parts of line changes.

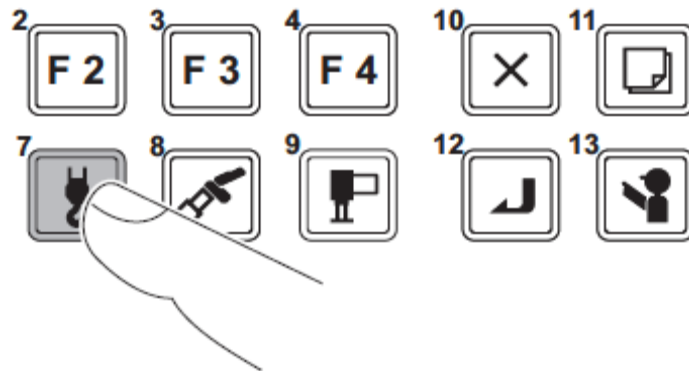

- The hook block is automatically selected and shown according to the registered boom configuration. If you must change the registration boom configuration to different hook block symbol, push the F1 (main hook block) key to change the indication.

Pop-up window for main hook block registration is displayed.

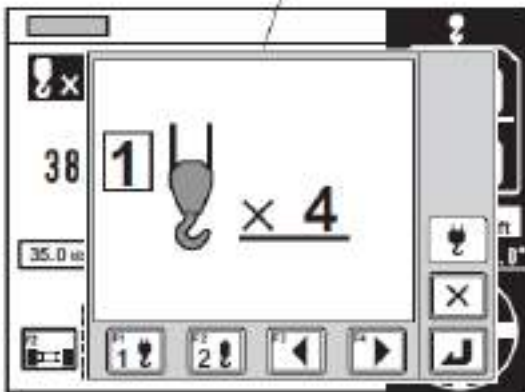

When main boom is registered

Pop-up window for auxiliary hook block registration is displayed.

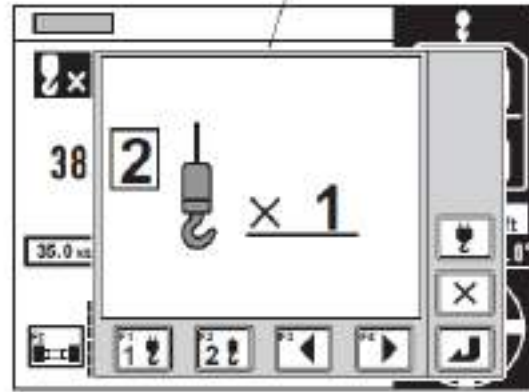

When auxiliary boom nose sheave/jib is registered

Appendix A

- You can register only the numbers of parts of line specified for each model.
 - Instead of the parts of line key, you can use the F3 (Backward) key or F4 (Forward) key to change the display of the number of parts of line.
 - When you want to abort registration, push the exit key. The pop-up window closes and the load moment indicator returns to the state before the start of the registration.
12. Push the set key to register the setting. After registration is completed, the pop-up window closes and the load moment indicator returns to the original screen.

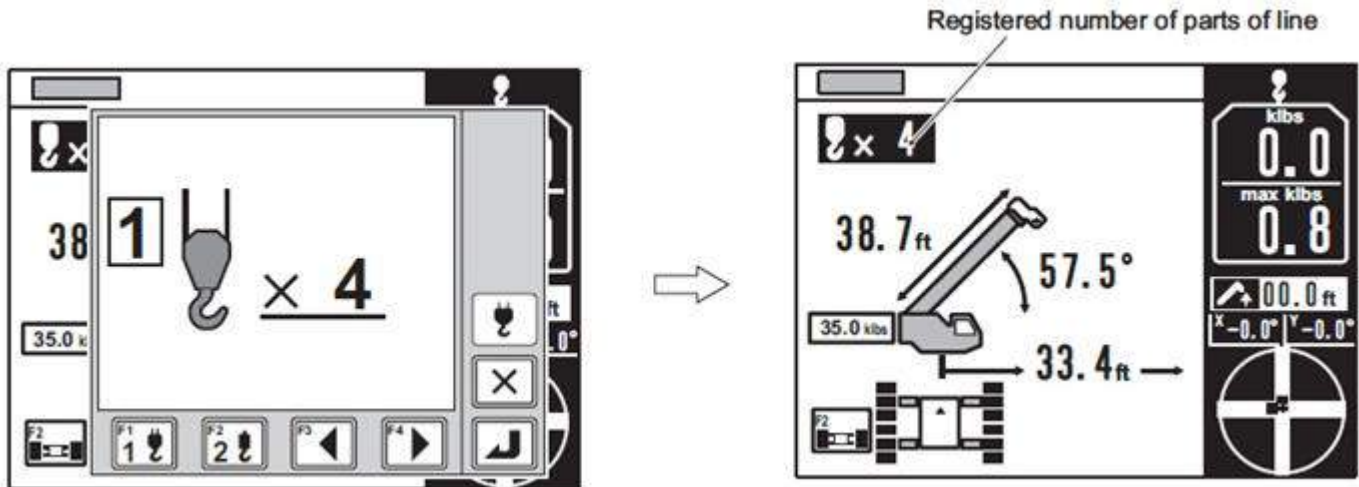

13. Push the F13 (check) key and make sure that the load moment indicator is in the condition below.

- LED Display: All lit except the drum indicator.
- Display Panel: All inverted.

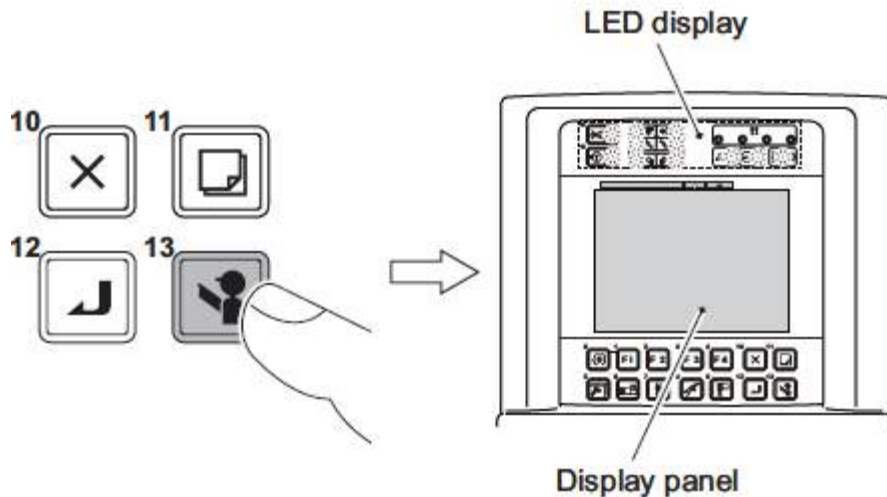

14. Attempt hoist-up, boom extension, and boom lowering operations to make sure that the crane does not move.

Appendix A

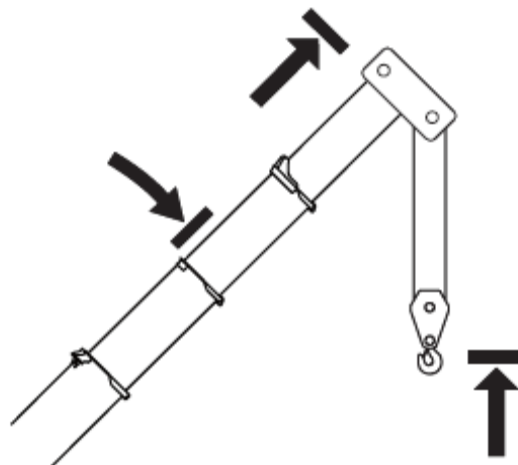

15. Push the F13 (check) key again to return to the original screen.

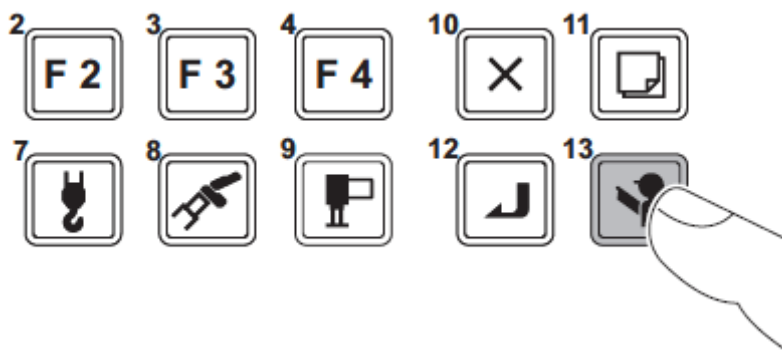

16. Make sure that the items on the display panel listed below agree with the actual condition.

- 1) Hook load
-Make sure that approximate hook mass is shown under a no-load condition.
- 2) Swing frame inclination
- 3) Swing frame inclination bar graph
- 4) Boom angle
- 5) Track/carbody jack configuration symbol
- 6) Counterweight configuration
- 7) Boom length
- 8) Number of parts of line
- 9) Extension length of jib length
(When extension or jib is selected)
- 10) Extension angle or jib offset angle
(When extension or jib is selected)
- 11) Work platform configuration
(When work platform is selected)

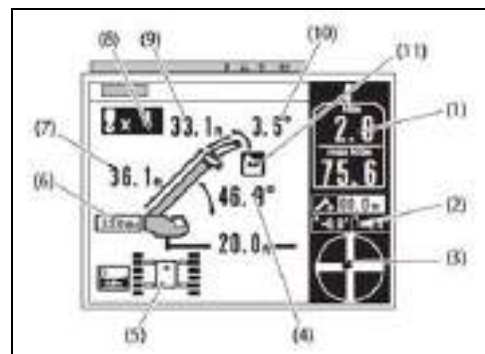

The hook block mass shown varies depending on the crane configuration, etc. At this point, you have successfully completed registration of the crane operating configuration and AML indicator. You can start crane operation.

NOTE

◆ Even after you turn off the load moment indicator, the registration information is retained for approximately 2 hours after the load moment indicator is turned off. In this case, it is necessary to register the operation configuration from the beginning.

5.3 ALARM AND RECOVERY OPERATION

Repair is necessary if any of the events below occurs:

- An error code not listed here is shown.
- The error code does not disappear even after you register the condition corresponding to the error code or perform the recovery operation.
- The crane remains halted and you cannot operate it. Contact your nearest Tadano distributor or dealer.

When any failure occurs or improper operation is performed during crane operation, the buzzer sounds and an error code is shown to ensure safety and to prevent damage to the machine. Examine the meaning of the error code, and perform recovery operation.

The error codes appear on the display panel. The load moment indicator has a built-in buzzer.

Load moment indicator built-in buzzer

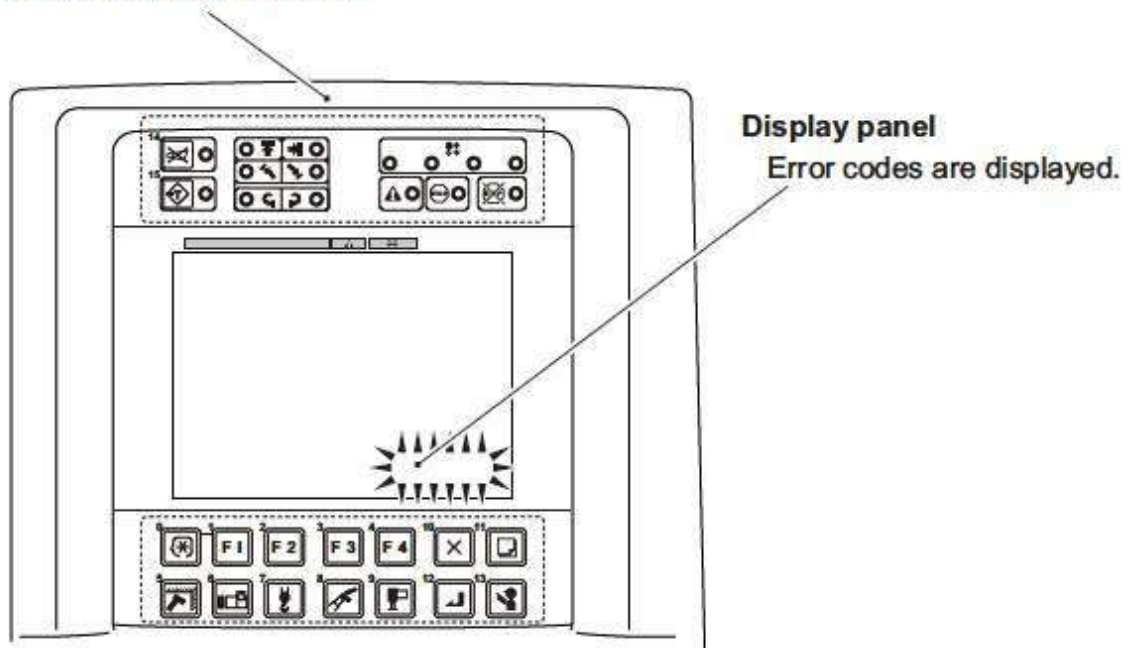

Appendix A

Stop Alarm

Error code	Buzzer	Crane state	Remedy
Ordinary bar graph display (no error code)  <small>K0000-00</small>	----	Load ratio is 100% or more.	Unwind the winch, or retract or raise the boom.
W0023	Load moment indicator built-in buzzer: beep-beep-beep (Short beeps repeat for 3 seconds.)	Crane is operated toward a critical side while the load ratio is 100% or more.	
W0024		Crane is operated toward a critical side while the hook block is in a two-block condition.	
W0025		Crane is operated toward a critical side while backward stability is low and the crane can overturn.	

Warning Alarm

Error code	Buzzer	Crane state	Remedy
Ordinary bar graph display (no error code)  <small>K00044-00</small>	----	Load ratio is 90% or more and less than 100%.	Carefully monitor the load ratio.
W0012	Load moment indicator built-in buzzer: beep-beep-beep (Short beeps repeat for 3 seconds.)	Backward stability is low and the crane can overturn.	Lower or extend the boom.
W0015		The stop function is canceled with the LMI/A2B switch while the hook block is in a two-block condition.	Unwind the winch or retract the boom to lower the hook block.
W0016		<ul style="list-style-type: none"> • Crane operation configuration goes out of the configuration registered to the load moment indicator. • An operation configuration with no capacity rated is registered to the load moment indicator. 	Register the operation configuration again.
W0017			
W0999		The power is turned on, while the battery for the load moment indicator built-in clock is exhausted.	Contact your nearest TADANO distributor or dealer for battery replacement.

5.4 OTHER FUNCTIONS

There are three other functions as shown below.

1. Work Range Alarm Function
2. TARE Function
3. User Adjustment Menu (Adjustment of display panel contrast)

5.4.1 Work Range Alarm Function

NOTE

◆ If the work range alarm is registered at a range too close to an obstacle depending on the crane configuration and operation methods. Consider a sufficient allowance when you register the alarm.

The work range alarm function warns the operator when the crane approaches the pre-registered boom angle (upper limit, lower limit), lifting height, and load radius. Use this function if you want warning when the crane is reaching the specified work range limit when there are obstacles around the machine.

When the crane reaches the registered working range, the alarm function works as shown below:

Work range alarm function	Crane state
Boom angle upper limit alarm	Load moment indicator built-in buzzer: beep-beep-beep (Short beeps repeat for 3 seconds.)
Boom angle lower limit alarm	
Lifting height alarm	
Load radius alarm	

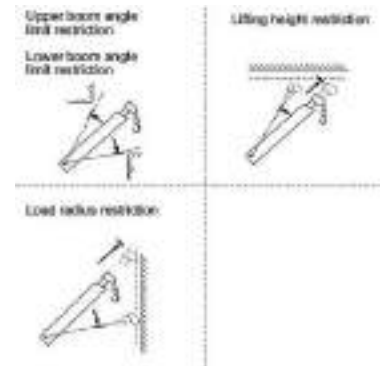

Display of Alarm Function Status

You can check the status of the work range alarm by the alarm indicator lamps on the LED display. The alarm indicator lamp(s) representing the work range alarm currently activated lights up. When the crane reaches the alarm limit range, the alarm indicator lamp changes from “staying lit” to “flashing”.

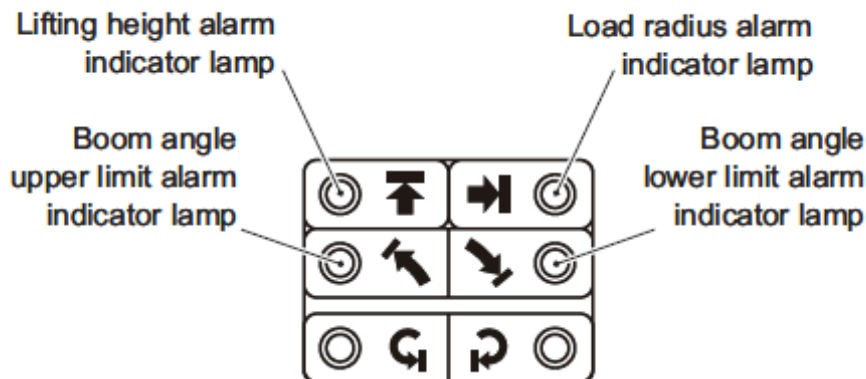

Appendix A

Registering Boom Angle, Lifting Height, and Load Radius Alarm

1. Push the work range alarm key to select the item to be registered.

- The pop-up window for work range alarm registration appears on the display panel.
- Every time you push the work range alarm key, the item to be selected changes in the following sequence.
 - 1) Lifting height alarm
 - 2) Load radius alarm
 - 3) Boom angle upper limit alarm
 - 4) Boom angle lower limit alarm
- The illustration below shows an example of display where “load radius alarm” is registered and “boom angle upper limit alarm” is selected.

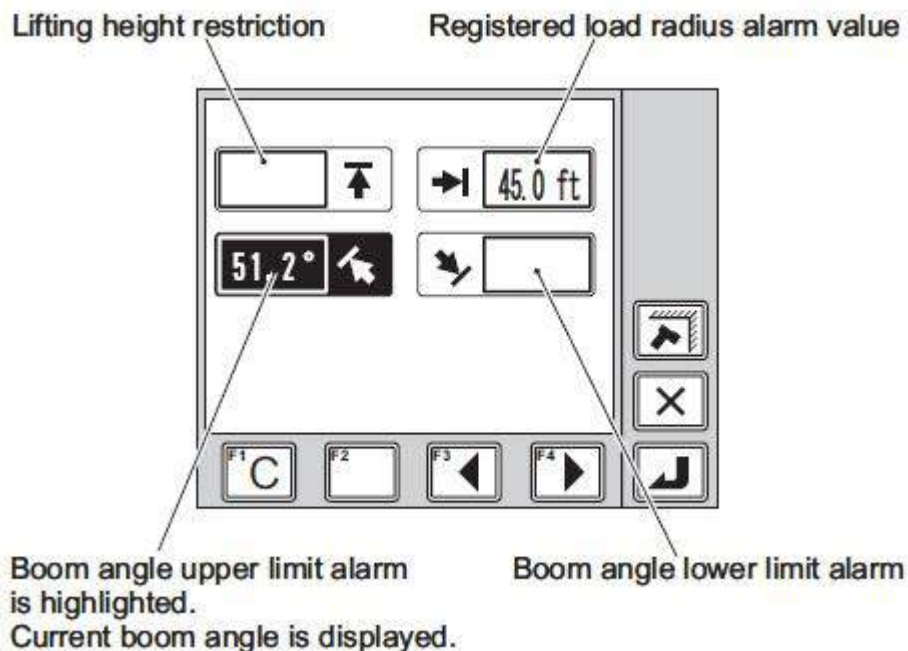
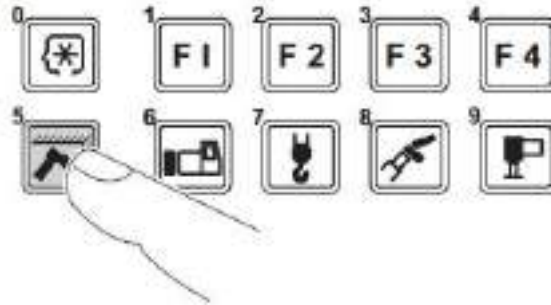

- Instead of the work range alarm key, you can use the F3 (Backward) key or F4 (Forward) key to change the display of the item to be selected.
 - When you want to stop registration, push the exit key. The pop-up window closes and the load moment indicator returns to the state before the start of the registration.
2. After you operate the boom (jib) to the desired boom angle, heights, and load radius, push the set key.
 - The corresponding alarm indicator lamp flashes in the LED display, and the work range alarm is registered.
 - After registration is completed, the pop-up window closes and the load moment indicator returns to the original screen.
 - If you select the item with the alarm value already registered, remember that pushing the set key cancels the registration of the work range alarm.

Appendix A

3. Move the boom (jib) within the alarm range.
 - The indicator lamp turns to staying lit.
 - When the crane reaches the registered alarm limit, the alarm indicator lamp flashes and the error code appears on the display panel. The load moment indicator built-in buzzer repeats short beeps for 3 seconds.
4. To cancel the alarm function, push the work range alarm key to select the item to be canceled.
 - The pop-up window for work range alarm registration is displayed.
5. Push the set key.
 - The corresponding alarm indicator lamp goes out.
 - The pop-up window closes and the load moment indicator returns to the original screen.
 - When you push the F1 (Clear) key, all the work range alarms are canceled.
 - Even after the load moment indicator is turned off, the registered information is retained for approximately 2 hours. When the load moment indicator is turned on, the operation starts with the retained information. The registered information is erased approximately 2 hours after the load moment indicator is turned off. In this case, it is necessary to register the operation configuration from the beginning.

Alarm and Recovery Operation

When the crane reaches the registered alarm limit, the load moment indicator buzzer sounds and the error code appears on the display panel. Examine the meaning of the error code and perform the recovery operation.

Error code	Buzzer	Crane state	Remedy
W0026	Load moment indicator built-in buzzer: beep-beep-beep (Long beeps repeat for 3 seconds.)	Crane is operated toward a critical side while the boom angle is at the upper alarm limit.	Lower the boom.
W0027		Crane is operated toward a critical side while the boom angle is at the lower alarm limit.	Raise the boom.
W0028		Crane is operated toward a critical side while the top end of the boom or jib is at the lifting height alarm limit.	Retract or lower the boom.
W0029		Crane is operated toward a critical side while the load radius is at the load radius alarm limit.	Retract or raise the boom.

5.4.2 TARE Function

The mass of the load only is shown on the hook load display.

1. Before you lift a load, push the TARE key.
 - The indication of the hook load display turns to “0” and the TARE indicator lamp lights up.

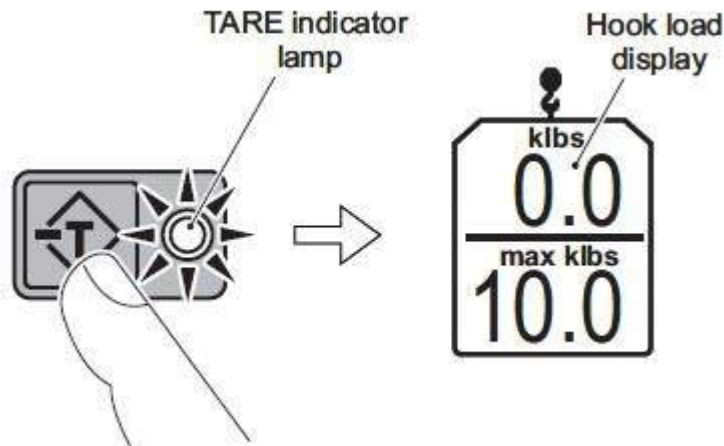

2. Perform hoist-up operation to lift up the load.
 - The mass of the load is shown on the hook load display.
3. To cancel the TARE function, push the TARE key again.
 - The hook load display returns to the original hook load display and the TARE indicator lamp goes out.

5.4.3 User Adjustment Menu



Do not operate the user adjustment menu during a crane operation. Distraction can cause a serious accident.

The functions below are available with the preset menu.

- Adjustment of display panel contrast.
1. Push the preset menu key.
 - The pop-up window for the preset menu selection appears on the display panel.

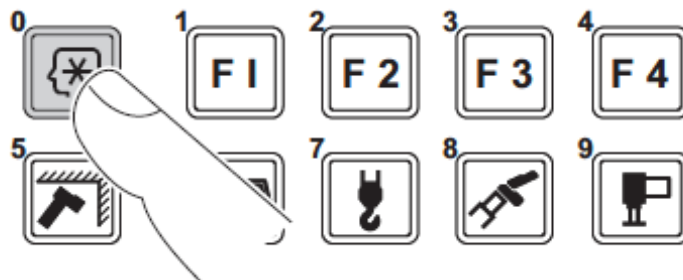

2. Push the F3 (Backward) key or F4 (Forward) key to select the preset icon.
 - The selected preset icon is highlighted.
 - Push the cancel key to exit the preset menu. The pop-up window closes and the crane operation configuration before the adjustment is restored.

Appendix A

Contrast adjustment icon

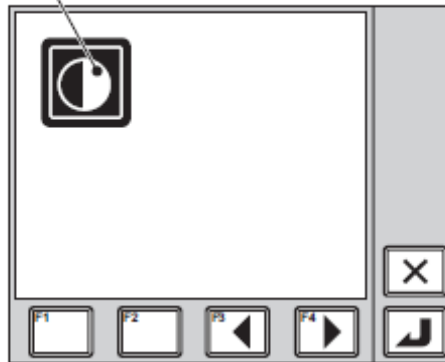

3. Push the set key.
 - The selected preset screen appears.

Adjustment of Display Panel Contrast

1. Select the contrast adjustment menu icon and the push the set key.
 - The pop-up window for contrast adjustment appears on the display panel.

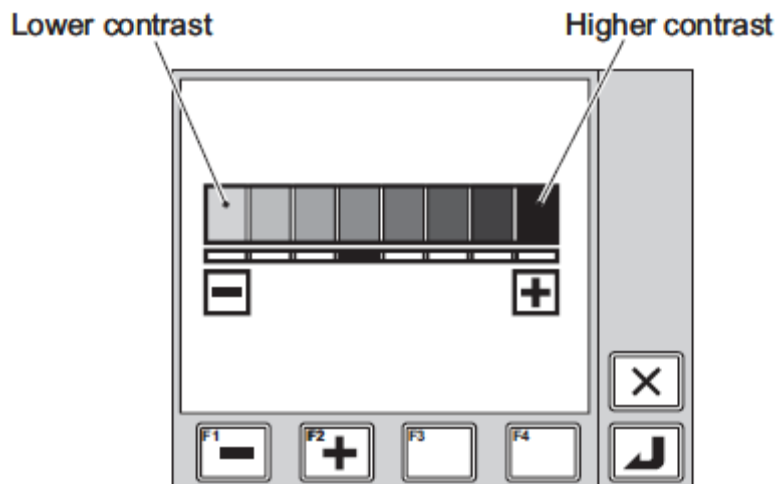

2. Push the F1 (-) key or F2 (+) key to adjust the contrast.
 - Push the F2 (+) key to increase contrast and the F1 (-) key to decrease contrast.
3. Push the set key.
 - When registration is completed, the pop-up window closes and the load moment indicator returns to the crane operation state.
 - When you want to stop registration, push the exit key. The pop-up window closes and the load moment indicator returns to the crane operation state without changing registration.
 - If you push the exit key for three seconds or more, the contrast returns to the initial setting.
 - Ever after the load moment indicator is turned off. The registered information is retained. When the load moment indicator is turned on, the operation starts with the retained information.

Action against Load Moment Indicator System Errors

If the cases listed below occur, an error in the load moment indicator system is likely cause.

- Even after a recovery operation corresponding to the error code, the error code does not disappear.
- An error code not mentioned in the error code list is shown.
- The crane remains halted and you cannot operate it.

In these cases stop the operation and stow the crane.

SECTION 6. APPENDIX B – DRUM ROTATION & LAST LAYER INDICATOR



Drum Rotation and Last Layer Indicator Installation Procedure



Field Service Literature (FSL-0016)

DRI Setup

Figure 1: Remove center plug from output shaft.



Figure 2: Rotate the unit to engage the shaft into driver.



Figure 3: Secure with two screws.



Figure 4: Loosen set screw on unit flange.



Figure 5: Rotate middle section to align output desired direction.



Figure 6: Tighten set screw.





Figure 7: Connect cables.

Wire connecting instructions:

Drum Rotation and Last Layer Indicators (IF Equipped)

Blue: Ground

Brown: +12 Volts DC

Black: Rotation Indicator
 Intermittent signal during rotation

Gray: Horn
 Solid signal from bare drum to first set point
 Intermittent signal from first set point to second set point

White: Solenoid (Optional)
 Off from bare drum to first set point
 Solid signal from first set point to full drum

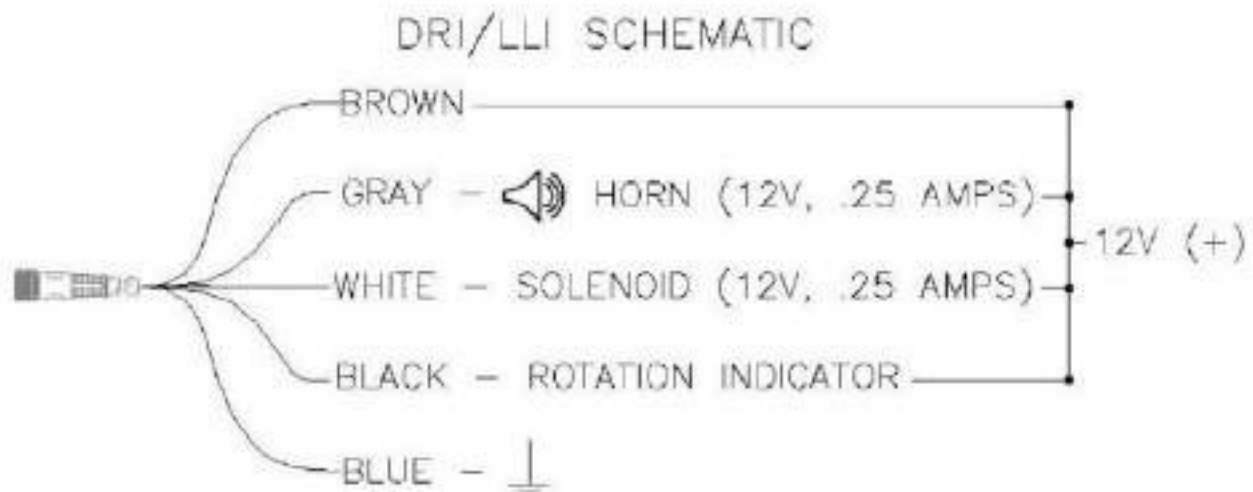

LLI Setup



Figure 8: Remove LLI (Last Layer Indicator) programming screw.



Figure 9: Follow below procedure to program LLI for last layer indication

1. Run winch to first set point.
(Tulsa Winch requires a minimum of 5 wraps of cable)
2. Turn power to the LLI off.
3. Remove LLI programming screw as shown in figure 8.
4. Push and hold learn button as shown in figure 9:
5. Turn power on. Then release learn button.
6. Run winch to second set point.
(Transition to second layer suggested)
7. Gently press and hold learn button.
(Excess force can cause damage to learn button and could affect LLI operation).
8. Wait couple of seconds and release learn button. *(The system is now set).*
9. Replace LLI programming screw.
(Failure to replace screw could affect LLI operation.)