

 7700

SENEBOGEN

PRELIMINARY



7700G

Crawler crane



321 kW (Stage V)



300 t



MAXCAB

<https://cranemanuals.com>

Stage V

7700G Advanced. The G-Series



1976-1995: S 1225 crawler crane with fly boom to lift casing boards

What makes up the G-Series

- 50 years of experience in construction of lattice boom and crawler cranes
- Modular construction with numerous configuration options
- Technology that can be mastered in operation and in service
- Long service life and high value stability

Your top benefits

1

Green Efficiency

Save fuel - reduce operating costs

Work quietly - protect operator and environment



2

Top-level performance

Robust boom system - operates up to a 4° tilt

3

Maximum usability

Maxcab comfort cab - work in comfort

SENCON - work program selection made easy



4

Flexible operation

Operate under full load - small space requirements

Strong undercarriage traction - good off-road mobility

5

Easy to transport

Starlifter undercarriage - quickly ready for use

Ballast support system - short set-up time

6

Maintenance and service made easy

SENNEBOGEN control system - easy diagnosis

Simple maintenance - clear labeling

7

Consultation and support in your area

3 production sites - 2 subsidiaries

150 sales partners - over 350 service stations



Also approved for
off-shore application*

* Reference: Dutch Offshore 3

7700G Technical data, equipment

MACHINE TYPE

Model (type) **7700**

ENGINE

Model	Cummins X12 (Stage V) 321 kW / 430 HP/ 436 PS at 1800 min⁻¹ 325 kW / 436 HP/ 442 PS at 1700 min⁻¹ Direct injection, turbo-charged, charge air cooling, reduced emissions
Cooling	Water-cooled
Diesel filter	Electrically heated with water separator
Air filter	Dry filter with pre-separator, automatic dust discharge, main element and safety element, contamination indicator
Fuel tank	max. 805 l (half-way up the sight glass)
DEF tank	105 l
Electr. system	24 V
Electrical installation	Easy and very clear
Batteries	2 x 180 Ah , main switch
Options	<ul style="list-style-type: none"> ■ Low temperature package with engine preheating ■ Electric fuel pump

UPPERCARRIAGE

Design	Torsion-resistant box design, precision crafted, bronze bushings for boom mounting arrangement, clear and very service-friendly concept, engine installed in the longitudinal direction, ballast support fixture
Electrical system	Central electrical distributor, battery disconnect switch
Lighting	LED headlights for optimal lighting of the work area
Safety	Camera monitoring of the rear area right side, uppercarriage railing right + left
Options	<ul style="list-style-type: none"> ■ Anti-corrosive maritime climate varnish ■ Low temperature package ■ Pinion tooth lubrication for slewing ring outer ■ Additional cameras available on customer request ■ Automatic central lubrication system for equipment and slewing ring



HYDRAULIC SYSTEM

Multi-circuit hydraulic system for optimum functionality and performance, all movements can be operated simultaneously.	
Pump type	The hydraulic pumps are variable displacement piston pumps with individual control and energy-saving flow-on-demand control.
Pump control	The pumps only pump as much oil as will actually be used. Pressure purging, load limit control
Operating pressure	max. 330 bar
Filtration	High-performance filtration with long-term change interval, contamination indicator, SENNEBOGEN HydroClean micro-filter system with water separator, option
Hydraulic tank	max. 860 l / 765 l (half-way up the sight glass)
Control system	Proportional, precision hydraulic servo control of the movements, 2 servo joysticks for work functions, additional functions via switches and foot pedals - arranged clearly and ergonomically. High energy efficiency due to large-scale hydraulic valves and lines. Measurement connections in the hydraulic circuits
Safety	Hydraulic circuits with safety valves
Options	<ul style="list-style-type: none"> ■ Bio-oil filling ■ SENNEBOGEN HydroClean micro-filter system with water separator

SLEWING

Gearbox	3 compact planetary gears with bent-axis hydraulic motor, integrated brake valves
Swing bearing brake	Spring-loaded multi-disk brake
Slewing ring	Three-row roller-bearing slewing ring with external gear teeth
Slewing speed	0-2 min⁻¹ , 3 adjustable slewing speeds
Options	<ul style="list-style-type: none"> ■ Positioning swing bearing brake

7700G Technical data, equipment

 CAB 	
Cab type	Maxcab, tiltable 20°
Cab equipment	Sliding door, sliding window in operator door, excellent ergonomics, automatic air conditioning, seat heater, air-suspension comfort seat, fresh air /circulating air filter, 12 V/24 V connections, SENCON, sunblind for skylight
Options	<ul style="list-style-type: none"> ■ Auxiliary heating system with timer ■ Activated-carbon filter for cab ■ Bullet proof skylight, rigidly glazed ■ Bullet proof cab windshield, rigidly glazed ■ Sunblind for windshield ■ Protective roof grating ■ FOPS protective grating for roof ■ Radio with Bluetooth ■ Electric cooling box

 UNDERCARRIAGE	
Design	Very strong Star-Lifter wide-gage crawler undercarriage, with integrated, protected drive transmission
Travel drive	Strong travel drive with axial piston hydraulic motor and directly attached automatically functioning brake valve and compact planetary gear on each running gear side
Parking brake	Spring-loaded multi-disk brake
Traveling gear	Maintenance-free flat track shoe traveling gear with hydraulic chain tension, 1200 mm flat track shoes
Travel speed	0 - 1.4 km/h
Options	<ul style="list-style-type: none"> ■ 1500 mm flat track shoes

 WINCH	
<p>The winches are driven via high-pressure-regulated adjustable hydraulic motors, thus there is always optimal pulling force speed control. Hydraulic lowering brake valves for sensitive, wear-free braking. Strong oil bath, planetary gear, low-maintenance. Holding brakes are spring-loaded, maintenance-free, low-wear disc brakes running in the oil bath, oil-cooled.</p>	
Main winches	
Cable pull max. 1st position	200 kN
Cable pull 7th position	150 kN
Cable diameter	28 mm
Drum diameter	725 mm
Cable speed	0 - 140 m/min
Cable capacity across 7 positions	610 m

 OPERATING WEIGHT	
Mass	approx. 293,000 kg 7700 basic machine with 1200 mm disk drive, 2 150 kN main winches, main boom consisting of lower boom section, 5.6 m boom section, head piece, 135 t counter weight, 40 t undercarriage ballast, 200 t hook and 650 m hoist cable
Note	Operating weight varies by model and equipment.

 EQUIPMENT	
Design	Decades of experience and the latest computer simulations guarantee the greatest degree of stability and life-span
Boom adjustment winch	Bent-axis hydraulic motor drive with compact planetary gear and 2 x 165 kN tensile force; rope diameter 26 mm, adjustment speed 30° to 80° in 77 sec.
Safety brake	Spring-loaded multi-disk brake
Crane safety	Latest generation of load moment monitoring, display shows all important data, lifting limit switch, pressure relief valves, cable exit protection
Boom	SH boom length up to 91.5 m
Options	<ul style="list-style-type: none"> ■ Max. boom length with SHLH equipment: 113.9 m ■ Max. boom length with SHWS equipment: 74.7 m + 74.7 m ■ Auxiliary boom for load capacities up to 42 t

7700G Crane equipment



Main boom SH

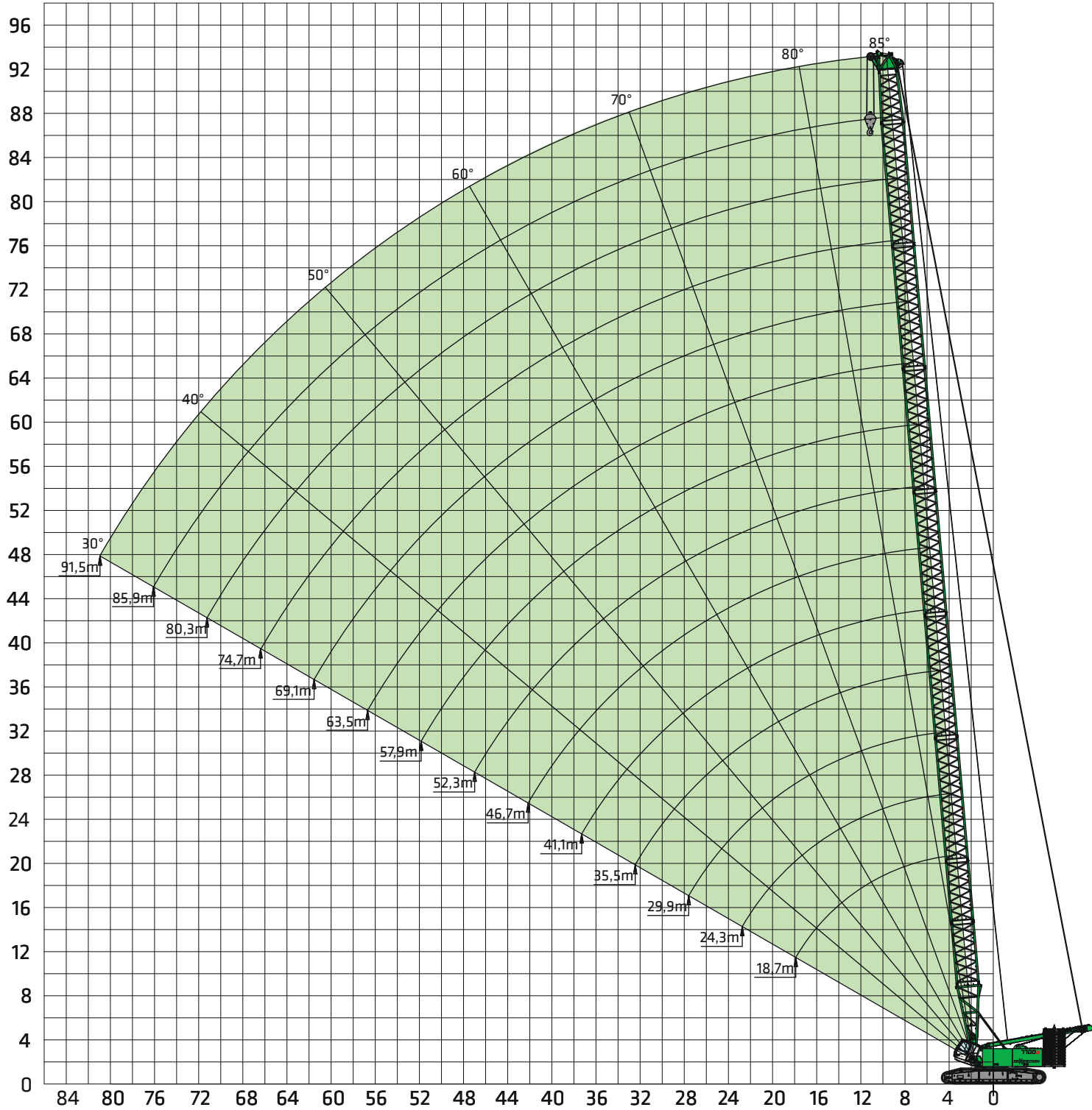

7700G Load ratings



Main boom SH



	Boom length [m]													
	18.7	24.3	29.9	35.5	41.1	46.7	52.3	57.9	63.5	69.1	74.7	80.3	85.9	91.5
5.0	300													
6.0	249.8	249.3	248.5											
7.0	216.1	215.5	209.7	227.9	179.6	167.5								
8.0	190.1	189.7	177.7	189.9	154.9	145.5	136.8	129.0						
9.0	169.6	164.5	153.9	162.4	135.9	128.4	121.3	114.9	108.8	97.9				
10.0	151.8	144.0	135.5	14.6	120.9	114.7	108.7	103.3	98.1	93.4	79.6			
12.0	114.3	114.1	109.0	112.2	98.5	94.0	89.5	85.5	81.5	77.9	74.3	64.9	55.2	48.0
14.0	91.1	90.9	90.4	92.4	82.6	79.1	75.6	72.4	69.2	66.3	63.3	60.6	53.0	45.5
16.0	75.4	75.1	74.5	78.2	70.8	68.0	65.0	62.4	59.7	57.3	54.7	52.4	50.0	43.4
18.0	63.9	63.6	63.1	67.4	61.6	59.3	56.7	54.5	52.2	50.0	47.8	45.8	43.7	41.6
20.0		54.9	54.4	57.9	53.1	52.3	50.0	48.1	46.0	44.1	42.1	40.3	38.4	36.7
24.0			42.0	47.0	40.7	40.2	39.5	38.4	36.6	35.1	33.4	31.9	30.2	28.8
28.0			33.7	36.9	32.4	31.9	31.1	30.5	29.7	28.4	26.9	25.6	24.1	22.8
32.0				29.9	26.4	25.9	25.1	24.5	23.7	23.1	21.9	20.7	19.4	18.2
36.0					21.8	21.4	20.6	20.0	19.2	18.5	17.7	16.8	15.6	14.5
40.0						17.8	17.0	16.4	15.6	15.0	14.2	13.5	12.5	11.4
44.0							14.1	13.6	12.8	12.1	11.3	10.6	9.8	8.9
48.0								11.2	10.4	9.8	8.9	8.3	7.4	6.7
52.0								9.2	8.4	7.8	7.0	6.3	5.5	4.8
56.0									6.7	6.1	5.3	4.6	3.8	3.1
60.0										4.7	3.8	3.2		
64.0														
68.0														
Number of falls	22	19	19	17	14	13	10	10	8	7	6	5	4	4

Table no. 7700R-80/3504/85.0/08.10 SH

Notes:

1. The load ratings given apply when the machine is on a firm and level surface.
2. The load ratings are given in tonnes and apply 360 degrees.
3. The load capacities take standards DIN 15019/2 and ISO 4305 into account (tilt angle 4.5°)
4. The weight of the load handling equipment (hooks, suspension gear) should be deducted from the load capacities.
5. The load ratings apply for the maximum undercarriage track width.
6. Load capacities must be limited or reduced in adverse conditions such as soft or uneven ground, slopes, wind, side loads, swinging loads, jolts or sudden stopping of loads, personnel and operators not experienced in handling loads.
7. Permissible cable pull per strand in crane mode for cable diameter 28 mm - 14,500 kg.
8. The load ratings apply to the SH boom (boom assembly as per operating instructions).
9. The load ratings apply for optimal boom assembly and pulley head with plastic rollers.
10. The load ratings given are for reference only. Please refer to the operating instructions for the relevant applicable load ratings.
11. Load ratings for tilts of 2° and 4° are also available on request.

7700G Load ratings



Main boom SH



 105 t 40 t	Boom length [m]													
	18.7	24.3	29.9	35.5	41.1	46.7	52.3	57.9	63.5	69.1	74.7	80.3	85.9	91.5
5.0	287.0													
6.0	261.8	261.3	260.5	230.0										
7.0	226.5	226.0	225.2	218.2	203.1	180.4								
8.0	199.3	198.9	198.1	186.8	177.9	167.2	157.4	130.1						
9.0	177.9	177.4	176.6	163.1	156.3	147.7	139.7	127.9	112.7	97.9				
10.0	160.5	160.0	155.7	144.5	139.1	132.1	125.4	119.3	110.7	96.0	79.6			
12.0	131.4	131.1	125.4	117.2	113.6	108.6	103.6	99.1	94.6	90.6	76.5	64.9	55.2	48.0
14.0	104.9	104.7	104.1	98.2	95.5	91.7	87.7	84.2	80.6	77.4	73.9	62.9	53.0	45.5
16.0	86.9	86.7	86.1	84.1	82.1	79.0	75.7	72.8	69.8	67.1	64.3	61.2	51.1	43.4
18.0	73.9	73.6	73.0	72.5	71.7	69.1	66.3	63.8	61.3	58.9	56.5	54.3	49.4	41.6
20.0		63.7	63.1	62.5	61.8	61.1	58.7	56.6	54.3	52.2	50.1	48.1	46.0	40.0
24.0			49.1	48.5	47.8	47.3	46.5	45.5	43.6	41.9	40.1	38.5	36.7	35.2
28.0			39.6	39.0	38.3	37.8	37.0	36.4	35.6	34.3	32.7	31.3	29.8	28.4
32.0				32.2	31.4	31.0	30.2	29.6	28.8	28.1	27.1	25.8	24.4	23.2
36.0					26.3	25.8	25.0	24.5	23.6	23.0	22.1	21.4	20.1	19.0
40.0						21.7	21.0	20.4	19.6	19.0	18.1	17.4	16.6	15.5
44.0							17.7	17.1	16.3	15.7	14.9	14.2	13.3	12.6
48.0								14.5	13.6	13.0	12.2	11.5	10.7	10.0
52.0								12.2	11.4	10.8	10.0	9.3	8.4	7.7
56.0									9.5	8.9	8.0	7.4	6.5	5.8
60.0										7.2	6.4	5.7	4.9	4.2
64.0											5.0	4.3	3.5	
68.0												3.0		
Number of falls	22	20	20	18	15	14	12	10	9	7	6	5	4	4

Table no. 7700R-80/3504/105.0/08.10 SH

Notes:

1. The load ratings given apply when the machine is on a firm and level surface.
2. The load ratings are given in tonnes and apply 360 degrees.
3. The load capacities take standards DIN 15019/2 and ISO 4305 into account (tilt angle 4.5°)
4. The weight of the load handling equipment (hooks, suspension gear) should be deducted from the load capacities.
5. The load ratings apply for the maximum undercarriage track width.
6. Load capacities must be limited or reduced in adverse conditions such as soft or uneven ground, slopes, wind, side loads, swinging loads, jolts or sudden stopping of loads, personnel and operators not experienced in handling loads.
7. Permissible cable pull per strand in crane mode for cable diameter 28 mm - 14,500 kg.
8. The load ratings apply to the SH boom (boom assembly as per operating instructions).
9. The load ratings apply for optimal boom assembly and pulley head with plastic rollers.
10. The load ratings given are for reference only. Please refer to the operating instructions for the relevant applicable load ratings.
11. Load ratings for tilts of 2° and 4° are also available on request.

7700G Load ratings



Main boom SH



 135 t 40 t Boom radius [m]	Boom length [m]													
	18.7	24.3	29.9	35.5	41.1	46.7	52.3	57.9	63.5	69.1	74.7	80.3	85.9	91.5
5.0														
6.0														
7.0						180.4								
8.0					198.6	177.1	158.0	130.1						
9.0				185.5	186.8	174.2	155.1	127.9	112.7	97.9				
10.0			170.5	169.9	166.5	158.3	150.4	125.9	110.7	96.0	79.6			
12.0		142.9	142.2	140.9	136.3	130.4	124.6	119.4	107.3	92.6	76.5	64.9	55.2	48.0
14.0	122.7	122.3	121.6	118.3	115.0	110.5	105.9	101.9	97.8	89.7	73.9	62.9	53.0	45.5
16.0	104.3	104.0	103.4	101.7	99.1	95.5	91.8	88.4	85.0	81.9	71.7	61.2	51.1	43.4
18.0	88.8	88.6	88.0	87.4	86.7	83.8	80.6	77.8	74.9	72.3	69.5	59.7	49.4	41.6
20.0		76.8	76.3	75.7	75.0	74.4	71.6	69.2	66.7	64.4	61.9	58.4	47.9	40.0
24.0			59.7	59.1	58.4	57.9	57.1	56.1	54.0	52.2	50.2	48.4	45.4	37.5
28.0			48.4	47.9	47.1	46.7	45.9	45.3	44.5	43.3	41.5	40.0	38.3	35.7
32.0				39.8	39.1	38.6	37.8	37.2	36.4	35.7	34.9	33.5	32.0	30.6
36.0					32.9	32.5	31.7	31.1	30.3	29.7	28.8	28.1	26.9	25.7
40.0						27.7	26.9	26.3	25.5	24.9	24.1	23.4	22.5	21.6
44.0							23.1	22.5	21.7	21.1	20.2	19.5	18.7	18.0
48.0								19.3	18.5	17.9	17.1	16.4	15.5	14.8
52.0								16.7	15.9	15.2	14.4	13.8	12.9	12.2
56.0									13.6	13.0	12.2	11.5	10.7	10.0
60.0										11.0	10.2	9.6	8.7	8.0
64.0											8.5	7.9	7.0	6.4
68.0												6.4	5.6	4.9
Number of falls	9	11	13	14	15	14	12	10	9	7	6	5	4	4

Table no. 7700R-80/3504/135.0/08.10 SH

Notes:

- The load ratings given apply when the machine is on a firm and level surface.
- The load ratings are given in tonnes and apply 360 degrees.
- The load capacities take standards DIN 15019/2 and ISO 4305 into account (tilt angle 4.5°)
- The weight of the load handling equipment (hooks, suspension gear) should be deducted from the load capacities.
- The load ratings apply for the maximum undercarriage track width.
- Load capacities must be limited or reduced in adverse conditions such as soft or uneven ground, slopes, wind, side loads, swinging loads, jolts or sudden stopping of loads, personnel and operators not experienced in handling loads.
- Permissible cable pull per strand in crane mode for cable diameter 28 mm - 14,500 kg.
- The load ratings apply to the SH boom (boom assembly as per operating instructions).
- The load ratings apply for optimal boom assembly and pulley head with plastic rollers.
- The load ratings given are for reference only. Please refer to the operating instructions for the relevant applicable load ratings.
- Load ratings for tilts of 2° and 4° are also available on request.

7700G Crane equipment



Main boom SHLH

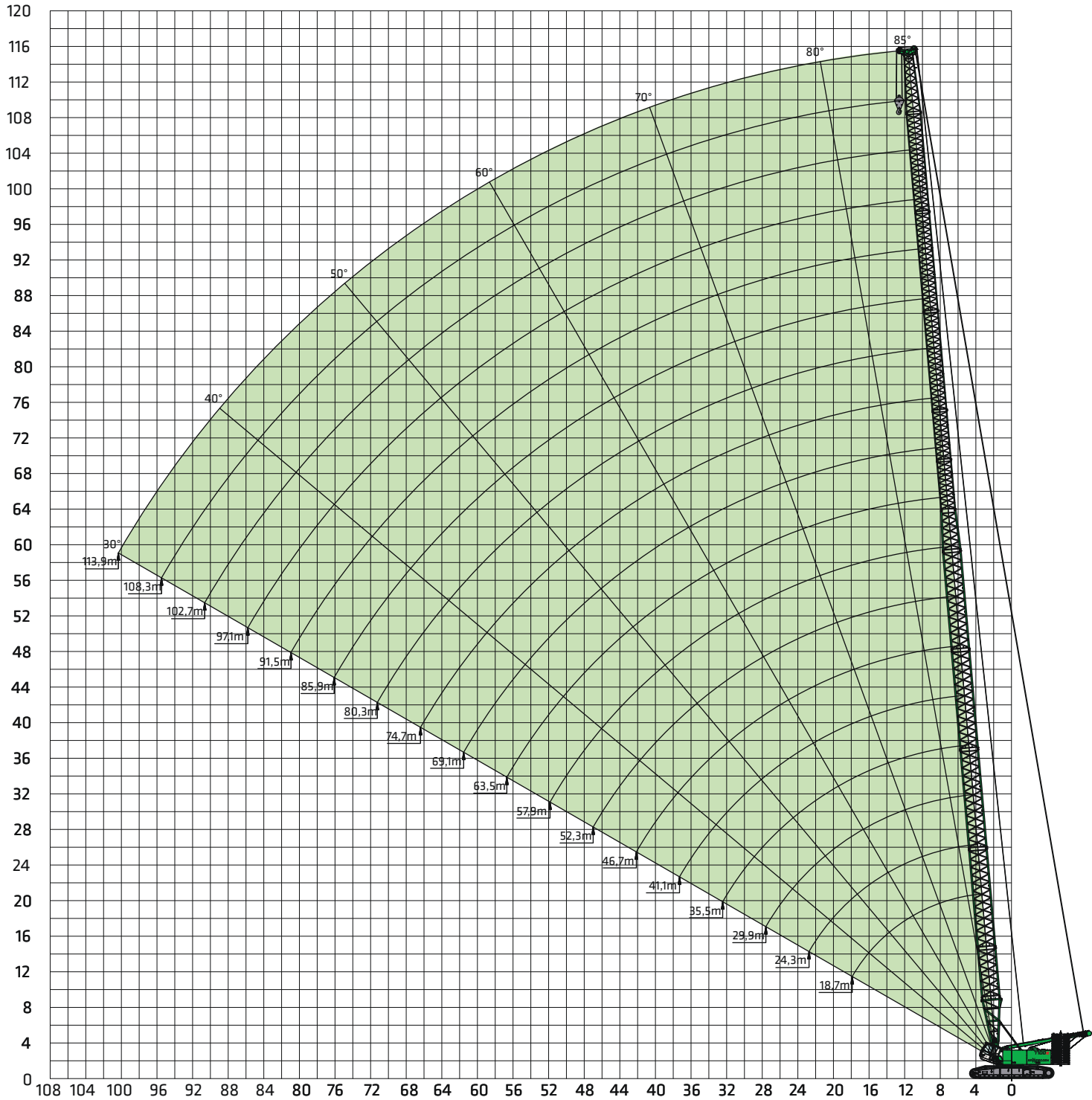

7700G Load ratings



Main boom SHLH



 85 t 40 t	Boom length [m]								
	69.1	74.7	80.3	85.9	91.5	97.1	102.7	108.3	113.9
9.0	87.0								
10.0	83.9	73.0							
12.0	77.9	67.4	60.0	49.7	41.0	34.5			
14.0	68.5	62.3	56.2	46.6	38.7	32.9	26.8	23.5	19.0
16.0	59.5	57.7	52.6	43.7	36.6	31.4	25.7	22.6	18.5
18.0	52.4	50.8	49.2	41.0	34.6	29.9	24.6	21.7	17.9
20.0	46.5	45.2	44.0	38.5	32.7	28.5	23.6	20.8	17.4
24.0	37.4	36.4	35.6	33.9	29.4	25.9	21.7	19.3	16.3
28.0	30.8	30.0	29.3	28.5	26.4	23.5	19.9	17.8	15.2
32.0	25.1	24.9	24.5	23.8	23.2	21.3	18.3	16.4	14.1
36.0	20.6	20.4	20.3	20.0	19.6	18.9	16.7	15.1	13.1
40.0	17.1	16.9	16.8	16.5	16.3	16.0	15.3	13.8	12.0
44.0	14.2	14.0	14.0	13.7	13.5	13.2	12.9	12.5	11.0
48.0	11.9	11.7	11.6	11.4	11.2	10.8	10.6	10.2	9.9
52.0	9.9	9.7	9.7	9.4	9.2	8.9	8.7	8.3	8.0
56.0	8.2	8.1	8.0	7.8	7.6	7.3	7.0	6.7	6.4
60.0	6.7	6.6	6.6	6.3	6.2	5.9	5.6	5.3	5.0
64.0		5.3	5.3	5.1	4.9	4.6	4.4	4.0	3.8
68.0			4.2	4.0	3.8	3.5	3.3	3.0	2.7
72.0				3.0	2.8	2.5	2.3		
76.0									
Number of falls	7	6	5	4	3	3	2	2	2

Table no. 7700R-80/3504/85.0/08.10 SHLH

Notes:

1. The load ratings given apply when the machine is on a firm and level surface.
2. The load ratings are given in tonnes and apply 360 degrees.
3. The load capacities take standards DIN 15019/2 and ISO 4305 into account (tilt angle 4.5°)
4. The weight of the load handling equipment (hooks, suspension gear) should be deducted from the load capacities.
5. The load ratings apply for the maximum undercarriage track width.
6. Load capacities must be limited or reduced in adverse conditions such as soft or uneven ground, slopes, wind, side loads, swinging loads, jolts or sudden stopping of loads, personnel and operators not experienced in handling loads.
7. Permissible cable pull per strand in crane mode for cable diameter 28 mm - 14,500 kg.
8. The load ratings apply to the SHLH boom (boom assembly as per operating instructions).
9. The load ratings apply for optimal boom assembly and pulley head with plastic rollers.
10. The load ratings given are for reference only. Please refer to the operating instructions for the relevant applicable load ratings.
11. Load ratings for tilts of 2° and 4° are also available on request.

7700G Load ratings



Main boom SHLH



 105 t 40 t Boom radius [m]	Boom length [m]								
	69.1	74.7	80.3	85.9	91.5	97.1	102.7	108.3	113.9
9.0	87.0								
10.0	83.9	73.0							
12.0	77.9	67.4	60.0	49.7	41.0	34.5			
14.0	72.1	62.3	56.2	46.6	38.7	32.9	26.8	23.5	19.0
16.0	66.4	57.7	52.6	43.7	36.6	31.4	25.7	22.6	18.5
18.0	61.0	53.5	49.2	41.0	34.6	29.9	24.6	21.7	17.9
20.0	54.6	49.6	46.0	38.5	32.7	28.5	23.6	20.8	17.4
24.0	44.3	42.8	40.0	33.9	29.4	25.9	21.7	19.3	16.3
28.0	36.7	35.8	34.5	29.7	26.4	23.5	19.9	17.8	15.2
32.0	30.2	30.0	29.6	26.0	23.7	21.3	18.3	16.4	14.1
36.0	25.0	24.9	24.7	22.6	21.3	19.3	16.7	15.1	13.1
40.0	20.4	20.9	20.7	19.6	19.0	17.4	15.3	13.8	12.0
44.0	16.9	17.6	17.5	16.8	16.9	15.7	13.9	12.6	11.0
48.0	14.3	15.0	14.5	14.2	14.4	14.0	12.6	11.4	10.0
52.0	12.6	12.7	11.9	11.9	12.2	11.9	11.4	10.3	9.0
56.0	11.0	10.8	9.7	9.8	10.3	10.0	9.8	9.1	8.1
60.0	9.3	9.2	8.0	8.0	8.7	8.4	8.2	7.8	7.2
64.0		7.7	7.0	6.5	7.3	7.0	6.8	6.4	6.1
68.0			6.4	5.4	6.1	5.8	5.5	5.2	4.9
72.0			5.3	4.7	4.9	4.7	4.4	4.1	3.8
76.0			4.3	4.1	4.0	3.7	3.5	3.1	2.9
Number of falls	7	6	5	4	3	3	2	2	2

Table no. 7700R-80/3504/105.0/08.10 SHLH

Notes:

1. The load ratings given apply when the machine is on a firm and level surface.
2. The load ratings are given in tonnes and apply 360 degrees.
3. The load capacities take standards DIN 15019/2 and ISO 4305 into account (tilt angle 4.5°)
4. The weight of the load handling equipment (hooks, suspension gear) should be deducted from the load capacities.
5. The load ratings apply for the maximum undercarriage track width.
6. Load capacities must be limited or reduced in adverse conditions such as soft or uneven ground, slopes, wind, side loads, swinging loads, jolts or sudden stopping of loads, personnel and operators not experienced in handling loads.
7. Permissible cable pull per strand in crane mode for cable diameter 28 mm - 14,500 kg.
8. The load ratings apply to the SHLH boom (boom assembly as per operating instructions).
9. The load ratings apply for optimal boom assembly and pulley head with plastic rollers.
10. The load ratings given are for reference only. Please refer to the operating instructions for the relevant applicable load ratings.
11. Load ratings for tilts of 2° and 4° are also available on request.

7700G Load ratings



Main boom SHLH



 135 t 40 t	Boom length [m]								
	69.1	74.7	80.3	85.9	91.5	97.1	102.7	108.3	113.9
9.0	87.0								
10.0	83.9	73.0							
12.0	77.9	67.4	60.0	49.7	41.0	34.5			
14.0	72.1	62.3	56.2	46.6	38.7	32.9	26.8	23.5	19.0
16.0	66.4	57.7	52.7	43.7	36.6	31.4	25.7	22.6	18.5
18.0	61.0	53.5	49.2	41.0	34.6	29.9	24.6	21.7	17.9
20.0	55.8	49.6	46.0	38.5	32.7	28.5	23.6	20.8	17.4
24.0	46.0	42.8	40.0	33.9	29.4	25.9	21.7	19.3	16.3
28.0	37.3	37.0	34.5	29.7	26.4	23.5	19.9	17.8	15.2
32.0	30.9	30.7	29.6	26.0	23.7	21.3	18.3	16.4	14.1
36.0	25.0	25.7	25.1	22.6	21.3	19.3	16.7	15.1	13.1
40.0	20.4	21.8	21.2	19.6	19.0	17.4	15.3	13.8	12.0
44.0	16.9	18.7	17.6	16.8	16.9	15.7	13.9	12.6	11.0
48.0	14.3	16.0	14.5	14.2	14.9	14.0	12.6	11.4	10.0
52.0	12.6	13.4	11.9	11.9	12.9	12.5	11.4	10.3	9.0
56.0	11.5	11.1	9.7	9.8	11.1	10.9	10.2	9.1	8.1
60.0	10.2	9.5	8.0	8.0	9.4	9.2	9.0	8.0	7.2
64.0		8.6	7.0	6.5	7.9	7.8	7.5	7.0	6.3
68.0			6.6	5.4	6.6	6.5	6.3	5.9	5.5
72.0				4.8	5.7	5.4	5.1	4.8	4.5
76.0				4.7	4.6	4.3	4.1	3.8	3.5
80.0					3.6	3.4	3.2	2.8	2.6
Number of falls	7	6	5	4	3	3	2	2	2

Table no. 7700R-80/3504/135.0/08.10 SHLH

Notes:

1. The load ratings given apply when the machine is on a firm and level surface.
2. The load ratings are given in tonnes and apply 360 degrees.
3. The load capacities take standards DIN 15019/2 and ISO 4305 into account (tilt angle 4.5°)
4. The weight of the load handling equipment (hooks, suspension gear) should be deducted from the load capacities.
5. The load ratings apply for the maximum undercarriage track width.
6. Load capacities must be limited or reduced in adverse conditions such as soft or uneven ground, slopes, wind, side loads, swinging loads, jolts or sudden stopping of loads, personnel and operators not experienced in handling loads.
7. Permissible cable pull per strand in crane mode for cable diameter 28 mm - 14,500 kg.
8. The load ratings apply to the SHLH boom (boom assembly as per operating instructions).
9. The load ratings apply for optimal boom assembly and pulley head with plastic rollers.
10. The load ratings given are for reference only. Please refer to the operating instructions for the relevant applicable load ratings.
11. Load ratings for tilts of 2° and 4° are also available on request.

7700G Additional equipment

Main boom SH with S 42.1 auxiliary boom
max. load capacity 42.0 t

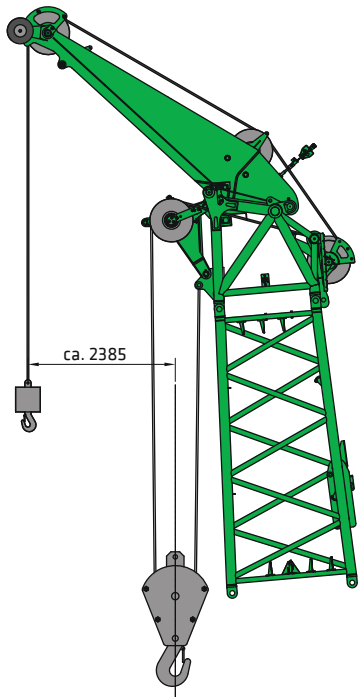

Main boom SHLH with S 42.1 auxiliary boom
max. load capacity 20.0 t

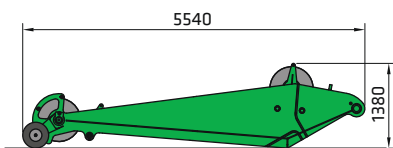
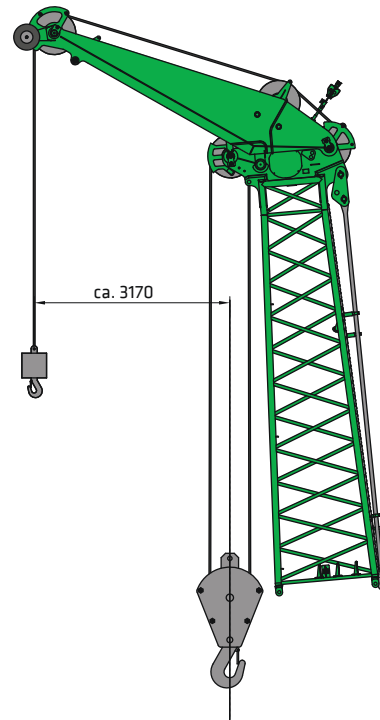

S 42.1 auxiliary boom
Weight: 1300 kg
Load capacity: max. 42.0 t

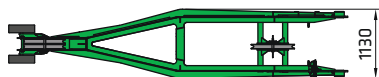

7700G Crane equipment



Main boom SH
with tiltable WS fly boom

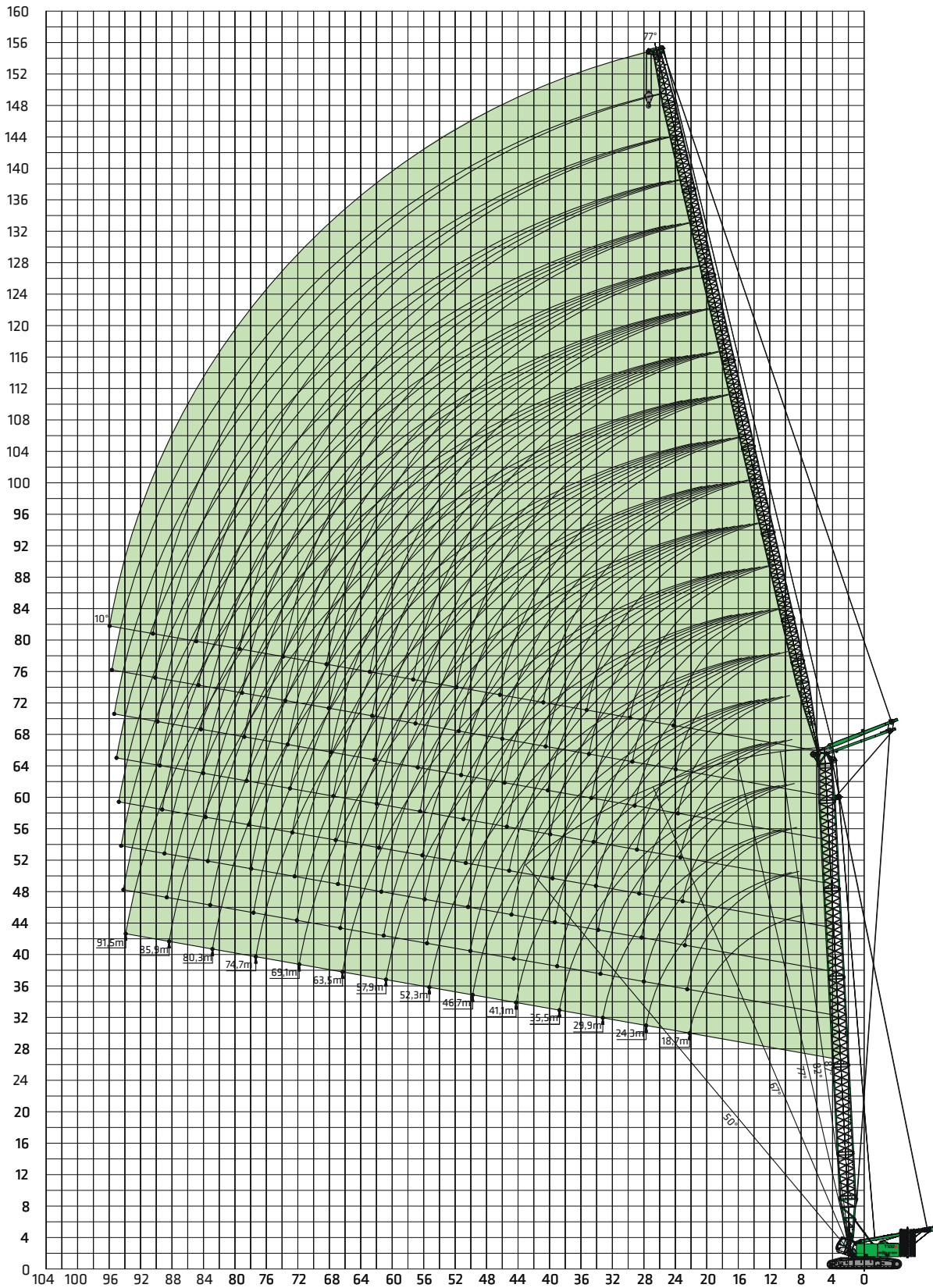

Subject to change.

7700G Load ratings



Main boom SH
with tiltable WS fly boom



		Main boom length 24.3 m							Main boom length 29.9 m						
Fly boom length		18.7	29.9	41.1	52.3	63.5	74.7	91.5	18.7	29.9	41.1	52.3	63.5	74.7	91.5
Reach [m]	10.0	95.0							92.5						
	12.0	91.5							89.4						
	14.0	88.6	81.0						86.7	76.8					
	16.0	86.0	76.2	61.4					83.7	73.1	57.1				
	18.0	78.3	71.9	58.2	36.6				75.5	69.5	54.7	33.8			
	20.0	68.2	65.6	55.2	35.8	23.7			67.0	63.5	52.4	33.1	22.7		
	24.0		54.2	50.0	34.0	22.8	14.5			52.8	48.1	31.8	21.7	14.1	
	28.0		44.4	43.9	32.3	21.8	13.9	5.9		44.3	42.7	30.6	20.8	13.6	5.1
	32.0		36.9	37.1	30.7	20.8	13.3	5.6		36.9	36.6	29.5	20.0	13.0	4.8
	36.0			31.8	29.4	19.9	12.7	5.4			31.7	28.5	19.3	12.4	4.6
	40.0			27.5	26.9	19.0	12.1	5.1			27.5	26.8	18.6	11.9	4.4
	48.0				20.8	17.5	11.1	4.6				20.8	17.4	11.0	4.0
	56.0					16.0	10.2	4.1					16.0	10.2	3.5
	64.0					12.7	9.6	3.4					12.7	9.5	3.1
	72.0						8.9	2.8						8.9	2.6
	80.0														
84.0															
Number of falls		7	7	5	3	2	2	1	7	6	5	3	2	1	1

		Main boom length 35.5 m							Main boom length 41.1 m						
Fly boom length		18.7	29.9	41.1	52.3	63.5	74.7	91.5	18.7	29.9	41.1	52.3	63.5	74.7	91.5
Reach [m]	10.0	92.5													
	12.0	89.4							83.6						
	14.0	86.7	68.5						81.4	61.8					
	16.0	83.7	66.1						78.3	59.8					
	18.0	75.5	63.5	52.8	31.0				70.0	57.3	48.7	29.5			
	20.0	67.0	59.4	51.2	30.4	21.7			63.4	54.3	46.8	29.1			
	24.0		49.8	49.5	29.5	20.6	13.8			47.9	45.2	28.0	19.5	12.8	
	28.0		42.7	46.2	28.8	19.8	13.2	4.3		41.4	42.3	27.2	18.7	12.4	4.4
	32.0		37.1	41.5	28.3	19.2	12.7	4.0		36.1	38.9	26.4	18.1	11.9	4.1
	36.0		32.0	36.2	27.7	18.7	12.2	3.8		31.7	35.2	25.6	17.4	11.4	3.9
	40.0			31.6	26.6	18.2	11.7	3.6			31.0	24.7	16.9	10.8	3.6
	48.0			27.7	20.9	17.2	10.9	3.3			27.4	20.7	15.7	9.9	3.2
	56.0				16.9	16.0	10.1	3.0				16.8	14.6	9.1	2.9
	64.0					13.1	9.5	2.7					12.7	8.4	2.6
	72.0						9.1							7.9	
	80.0														
88.0															
Number of falls		7	6	4	3	2	1	1	6	5	4	3	2	1	1

Notes:

1. The load ratings given apply when the machine is on a firm and level surface.
2. The load ratings are given in tonnes and apply 360 degrees.
3. The load capacities take standards DIN 15019/2 and ISO 4305 into account (tilt angle 4.5°)
4. The weight of the load handling equipment (hooks, suspension gear) should be deducted from the load capacities.
5. The load ratings apply for the maximum undercarriage track width.
6. Load capacities must be limited or reduced in adverse conditions such as soft or uneven ground, slopes, wind, side loads, swinging loads, jolts or sudden stopping of loads, personnel and operators not experienced in handling loads.
7. Permissible cable pull per strand in crane mode for cable diameter 28 mm - 14,500 kg.
8. The load ratings apply to the SHWS boom (boom assembly as per operating instructions).
9. The load ratings apply for optimal boom assembly and pulley head with plastic rollers.
10. Load ratings for tilts of 2° and 4° are also available on request.
11. The load ratings given are for reference only. Please refer to the operating instructions for the relevant applicable load ratings.

7700G Load ratings



Main boom SH
with tiltable WS fly boom



105 t 40 t 87° SH		Main boom length 46.7 m							Main boom length 52.3 m						
Fly boom length		18.7	29.9	41.1	52.3	63.5	74.7	91.5	18.7	29.9	41.1	52.3	63.5	74.7	91.5
Reach [m]	12.0	80.0							76.7						
	14.0	78.0	61.8						73.3	57.0					
	16.0	75.2	59.0	44.6					69.3	54.3	40.7				
	18.0	67.4	56.7	42.4					63.7	52.0	38.7				
	20.0	61.1	54.7	40.8	27.7				58.8	49.8	37.2	25.5			
	24.0		48.2	38.4	26.6	18.5	11.9			44.5	34.8	24.3	17.4	11.2	
	28.0		41.6	36.4	25.5	17.7	11.5	4.5		39.6	32.8	23.2	16.7	10.9	4.5
	32.0		36.6	34.2	24.5	17.0	11.0	4.2		35.4	30.9	22.2	15.9	10.4	4.2
	36.0			30.3	23.6	16.2	10.5	3.9			28.1	21.3	15.1	9.8	3.9
	40.0			27.2	22.7	15.5	10.0	3.6			25.8	20.5	14.3	9.3	3.6
	48.0				20.5	14.2	8.9	3.1				18.7	12.9	8.2	3.0
	56.0				16.6	13.2	8.1	2.7					11.9	7.3	
64.0					12.2	7.4						10.9	6.5		
72.0						6.8							5.8		
80.0															
Number of falls		6	5	4	2	2	1	1	6	4	3	2	2	1	1

105 t 40 t 87° SH		Main boom length 57.9 m							Main boom length 63.5 m						
Fly boom length		18.7	29.9	41.1	52.3	63.5	74.7	91.5	18.7	29.9	41.1	52.3	63.5	74.7	91.5
Reach [m]	12.0	73.5							63.7						
	14.0	68.5	52.2						58.8	44.7					
	16.0	63.5	49.7	36.7					55.1	42.7					
	18.0	60.0	47.2	35.0					52.5	40.5	30.2				
	20.0	56.6	44.9	33.6	23.2				49.7	38.7	28.5	20.1			
	24.0	48.0	40.8	31.2	22.0	16.4			43.0	35.6	26.3	18.4	14.1		
	28.0		37.6	29.3	21.0	15.7	10.4	4.5		32.9	24.7	17.0	13.1	8.8	
	32.0		34.3	27.6	20.0	14.8	9.8	4.3		30.1	23.3	15.8	12.1	8.2	
	36.0			26.0	19.1	13.9	9.2	3.9			21.8	14.8	11.1	7.6	
	40.0			24.4	18.2	13.0	8.6	3.5			20.4	13.9	10.2	7.0	
	48.0				16.9	11.6	7.5	2.8				12.6	8.8	5.9	
	56.0				16.0	10.6	6.5					11.5	7.9	5.0	
64.0					9.6	5.7						7.0	4.2		
72.0						4.9							3.5		
76.0						4.3							3.2		
Number of falls		6	4	3	2	2	1	1	5	4	3	2	1	1	1

105 t 40 t 87° SH		Main boom length 69.1 m						
Fly boom length		18.7	29.9	41.1	52.3	63.5	74.7	91.5
Reach [m]	12.0	54.0						
	14.0	49.0						
	16.0	46.7	35.8					
	18.0	45.0	33.8	25.3				
	20.0	42.8	32.5	23.5	17.0			
	22.0	40.2	31.4	22.2	15.8			
	24.0	38.0	30.4	21.3	14.7	11.8		
	28.0		28.1	20.0	13.0	10.5	7.2	
	32.0		25.9	18.9	11.6	9.3	6.5	
	36.0			17.7	10.5	8.3	5.9	
	40.0			16.4	9.7	7.4	5.3	
	48.0				8.4	6.0	4.3	
56.0				7.0	5.1	3.5		
64.0					4.3	2.7		
72.0								
Number of falls		4	3	2	2	1	1	

Subject to change.

7700G Load ratings



Main SH boom
with tiltable WS fly boom



105 t 40 t 82° SH		Main boom length 24.3 m							Main boom length 29.9 m						
Fly boom length		18.7	29.9	41.1	52.3	63.5	74.7	91.5	18.7	29.9	41.1	52.3	63.5	74.7	91.5
Reach [m]	14.0	93.1							86.7						
	16.0	85.3							81.3						
	18.0	75.6	67.4						72.2	66.0					
	20.0	66.9	63.3	51.3					64.5	60.7					
	24.0	53.0	52.6	45.9	33.0				52.4	50.6	45.8	31.5			
	28.0		43.3	42.3	31.8	21.2				42.5	40.7	30.6	20.5		
	32.0		36.7	35.8	30.5	20.4	13.1			36.1	35.0	29.6	19.9	13.0	
	36.0			30.9	29.2	19.6	12.5				30.4	28.5	19.2	12.5	
	40.0			27.0	25.9	18.9	11.9	5.6			26.5	25.4	18.5	11.9	5.2
	48.0				20.3	17.6	10.9	4.6				19.9	17.2	10.9	4.4
	56.0				16.4	15.5	10.0	3.8				16.1	15.2	10.0	3.7
	64.0					12.7	9.2	3.3					12.4	9.2	3.1
	72.0						8.5	2.7						8.5	2.6
80.0															
88.0															
Number of falls		7	7	5	3	2	2	1	7	6	5	3	2	1	1

Table no. 7700R-80/3504/105.0/08.10 SHWS 82

105 t 40 t 82° SH		Main boom length 35.5 m							Main boom length 41.1 m						
Fly boom length		18.7	29.9	41.1	52.3	63.5	74.7	91.5	18.7	29.9	41.1	52.3	63.5	74.7	91.5
Reach [m]	16.0	77.3							73.4						
	18.0	68.8	64.5						65.5						
	20.0	62.0	58.2						59.2	55.6					
	24.0	51.7	48.7	45.7					49.5	46.5	43.7				
	28.0		41.7	39.1	29.5					39.9	37.5	28.2			
	32.0		35.6	34.1	28.6	19.4	12.9			34.5	32.7	27.1	18.3		
	36.0		30.7	29.8	27.8	18.8	12.5			30.1	28.7	26.1	17.5	11.5	
	40.0			26.1	24.9	18.1	12.1	4.8			25.4	23.8	16.7	11.0	4.4
	48.0			20.6	19.5	16.7	11.2	4.2			20.1	19.0	15.2	10.0	3.9
	56.0				15.7	14.8	10.3	3.7				15.3	13.8	9.1	3.6
	64.0					12.1	9.4	3.2					11.7	8.3	3.2
	72.0						8.8	2.7						7.7	2.7
	80.0						7.5							6.7	
88.0															
Number of falls		7	6	4	3	2	1	1	6	5	4	3	2	1	1

7700G Load ratings



Main SH boom
with tiltable WS fly boom



105 t 40 t 82° SH		Main boom length 46.7 m							Main boom length 52.3 m						
Fly boom length		18.7	29.9	41.1	52.3	63.5	74.7	91.5	18.7	29.9	41.1	52.3	63.5	74.7	91.5
Reach [m]	16.0	69.6													
	18.0	62.2							59.0						
	20.0	56.3	52.9						53.4						
	24.0	47.2	44.4	41.6					44.9	42.2	38.0				
	28.0		38.2	35.8	27.0					36.4	34.0	24.5			
	32.0		33.4	31.2	25.5	17.2				31.8	29.7	22.7	16.0		
	36.0		29.6	27.6	24.3	16.1	10.6			28.2	26.3	21.3	15.0	10.1	
	40.0			24.7	22.7	15.2	9.9	4.0			23.5	19.9	14.1	9.6	3.8
	48.0			19.7	18.4	13.7	8.8	3.7			19.0	16.7	12.6	8.6	3.5
	56.0				14.9	12.7	7.9	3.4				14.0	11.5	7.9	3.2
	64.0					11.3	7.2	3.2					10.4	7.2	3.0
	72.0						6.6	2.8					9.0	6.6	2.7
	80.0							5.9						5.9	
88.0															
92.0															
Number of falls		6	5	4	2	2	1	1	6	4	3	2	2	1	1

Table no. 7700R-80/3504/105.0/08.10 SHWS 82

105 t 40 t 82° SH		Main boom length 57.9 m							Main boom length 63.5 m						
Fly boom length		18.7	29.9	41.1	52.3	63.5	74.7	91.5	18.7	29.9	41.1	52.3	63.5	74.7	91.5
Reach [m]	18.0	55.7													
	20.0	50.5							47.7						
	24.0	42.6	40.1						40.2	37.8					
	28.0	36.8	34.5	32.2	22.0				34.8	32.6	29.2				
	32.0		30.3	28.2	19.8	14.7				28.6	25.9	18.4			
	36.0		26.9	25.0	18.3	13.8	9.5			25.4	23.0	16.6	12.3	8.4	
	40.0		24.3	22.3	17.0	12.9	9.2			23.0	20.6	15.2	11.4	8.1	
	48.0			18.3	15.0	11.5	8.5	3.3			17.1	12.8	9.8	7.2	
	56.0				13.1	10.4	7.8	3.0				10.5	8.5	6.3	
	64.0					9.4	7.2	2.8					7.2	5.4	
	72.0					8.4	6.6	2.6					6.1	4.6	
	80.0							5.9						3.8	
	88.0														
92.0															
Number of falls		6	4	3	2	2	1	1	5	4	3	2	1	1	

105 t 40 t 82° SH		Main boom length 69.1 m						
Fly boom length		18.7	29.9	41.1	52.3	63.5	74.7	91.5
Reach [m]	20.0	44.8						
	24.0	37.9	35.6					
	28.0	32.8	30.8	26.2				
	32.0		27.0	23.6	16.9			
	36.0		24.0	21.1	15.0	10.8		
	40.0		21.6	19.0	13.4	9.8	7.0	
	48.0			15.9	10.6	8.1	5.9	
	56.0				8.0	6.6	4.8	
	64.0					5.0	3.7	
	72.0					3.7	2.6	
Number of falls		4	3	2	2	1	1	

Subject to change.

7700G Load ratings



Main boom SH
with tiltable WS fly boom



105 t 40 t 77° SH		Main boom length 24.3 m							Main boom length 29.9 m						
Fly boom length		18.7	29.9	41.1	52.3	63.5	74.7	91.5	18.7	29.9	41.1	52.3	63.5	74.7	91.5
Reach [m]	18.0	73.2							67.7						
	20.0	65.1							61.9						
	24.0	51.6	51.0						50.3	48.5					
	28.0		42.0	41.0					40.7	38.9					
	32.0		35.5	34.6	33.1				34.6	33.4	31.4				
	36.0		30.6	29.8	28.6	23.2			29.9	28.9	27.4	22.7			
	40.0			26.0	24.9	22.0	15.3			25.3	24.1	21.7	15.1		
	48.0			20.5	19.5	18.5	13.7	5.8		19.9	18.8	17.8	13.6	5.4	
	56.0				15.7	14.8	12.0	5.0				15.1	14.2	12.0	4.7
	64.0					12.0	10.3	4.4					11.5	10.2	4.1
	72.0						8.8	3.8						8.5	3.6
	80.0						7.4	3.4						7.0	3.0
88.0							3.0								
96.0							2.6								
Number of falls		7	7	5	3	2	2	1	7	6	5	3	2	1	1

Table no. 7700R-80/3504/105.0/08.10 SHW5.77

105 t 40 t 77° SH		Main boom length 35.5 m							Main boom length 41.1 m						
Fly boom length		18.7	29.9	41.1	52.3	63.5	74.7	91.5	18.7	29.9	41.1	52.3	63.5	74.7	91.5
Reach [m]	20.0	58.8													
	24.0	48.9	46.1						46.0						
	28.0	40.5	39.4	36.9					38.7	37.2					
	32.0		33.7	32.1	29.8					32.2	30.3				
	36.0		29.1	28.1	26.2					28.1	26.6	24.6			
	40.0		25.4	24.5	23.3	21.3				24.6	23.5	21.9	19.6		
	48.0			19.3	18.1	17.1	13.5	5.0			18.6	17.3	16.0	12.1	
	56.0				14.6	13.6	12.0	4.4				13.9	12.9	10.7	3.8
	64.0					11.0	10.0	3.9					10.4	9.2	3.5
	72.0					9.1	8.1	3.3					8.5	7.6	3.1
	80.0						6.6	2.7						6.1	2.7
	88.0														
96.0															
Number of falls		7	6	4	3	2	1	1	6	5	4	3	2	1	

7700G Load ratings



Main boom SH
with tiltable WS fly boom



105 t 40 t 77° SH		Main boom length 46.7 m							Main boom length 52.3 m						
Fly boom length		18.7	29.9	41.1	52.3	63.5	74.7	91.5	18.7	29.9	41.1	52.3	63.5	74.7	91.5
Reach [m]	24.0	47.0							40.5						
	28.0	36.9	35.1						34.8	32.6					
	32.0		30.6	28.5					30.4	28.6	26.4				
	36.0		27.1	25.2	23.1					25.3	23.4	20.7			
	40.0		23.8	22.4	20.5	17.8				22.4	20.9	18.9			
	48.0			17.9	16.5	15.0	10.7				16.8	15.2	13.7	10.6	
	56.0				13.3	12.1	9.5	3.3				12.3	11.0	9.0	
	64.0				10.8	9.8	8.5	3.1				10.1	8.9	7.6	
	72.0					8.0	7.0	2.9					7.3	6.1	
	80.0						5.6	2.7						4.9	
88.0														3.2	
96.0															
Number of falls		6	5	4	2	2	1	1	6	4	3	2	2	1	

Table no. 7700R-80/3504/105.0/08.10 SHWS.77

105 t 40 t 77° SH		Main boom length 57.9 m							Main boom length 63.5 m						
Fly boom length		18.7	29.9	41.1	52.3	63.5	74.7	91.5	18.7	29.9	41.1	52.3	63.5	74.7	91.5
Reach [m]	24.0	37.9													
	28.0	32.6							30.1						
	32.0	28.5	26.6						26.3	24.5					
	36.0		23.5	21.7						21.7	19.9				
	40.0		21.1	19.3	17.4					19.4	17.7	15.7			
	48.0			15.7	13.9	12.4	10.5				14.3	12.5	11.0	8.0	
	56.0			13.0	11.3	9.9	8.6				11.8	10.1	8.7	7.2	
	64.0				9.4	8.0	6.7					8.3	7.0	5.6	
	72.0					6.5	5.3						5.6	4.3	
	80.0						4.1							3.2	
88.0						3.2									
Number of falls		6	4	3	2	2	1		5	4	3	2	1	1	

105 t 40 t 77° SH		Main boom length 69.1 m						
Fly boom length		18.7	29.9	41.1	52.3	63.5	74.7	91.5
Reach [m]	28.0	27.6						
	32.0	24.2	22.5					
	36.0	21.5	19.8	18.0				
	40.0		17.7	16.0				
	48.0			12.9	11.1	9.7		
	56.0			10.6	8.9	7.6		
	64.0				7.3	5.9		
	72.0					4.7		
80.0					3.6			
Number of falls		4	3	2	2	1		

7700G Load ratings



Main boom SH
with tiltable WS fly boom



105 t 40 t 67° SH		Main boom length 24.3 m							Main boom length 29.9 m						
Fly boom length		18.7	29.9	41.1	52.3	63.5	74.7	91.5	18.7	29.9	41.1	52.3	63.5	74.7	91.5
Reach [m]	24.0	48.7													
	28.0	40.1							38.3						
	32.0		33.3						32.3	31.7					
	36.0		28.7	27.7					27.3						
	40.0		25.1	24.2					23.9	22.8					
	48.0			19.0	17.8	16.8				17.9	16.7				
	56.0				14.3	13.3	10.0				13.3	12.3	9.4		
	64.0					10.8	8.9	3.0			10.9	9.9	8.4		
	72.0					8.8	7.9	2.8				8.0	7.1		
	80.0						6.4	2.6						5.6	
88.0															
96.0															
Number of falls		7	7	5	3	2	2	1	7	6	5	3	2	1	

Table no. 7700R-80/3504/105.0/08.10 SHW5 67

105 t 40 t 67° SH		Main boom length 35.5 m							Main boom length 41.1 m						
Fly boom length		18.7	29.9	41.1	52.3	63.5	74.7	91.5	18.7	29.9	41.1	52.3	63.5	74.7	91.5
Reach [m]	28.0	36.5													
	32.0	30.9							29.0						
	36.0		25.9						25.0	24.2					
	40.0		22.6	21.5						21.1					
	48.0			16.8	15.5						15.6				
	56.0			13.6	12.4	11.3					12.5	11.2	10.1		
	64.0				10.0	9.0	7.9				9.0	8.0	6.8		
	72.0					7.3	6.2					6.4	5.3		
	80.0						4.9					5.0	4.1		
	88.0						3.8						3.1		
92.0												2.7			
Number of falls		7	6	4	3	2	1		6	5	4	3	2	1	

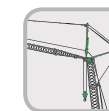

Main boom SH
with tiltable WS fly boom



105 t 40 t 67° SH		Main boom length 46.7 m							Main boom length 52.3 m						
Fly boom length		18.7	29.9	41.1	52.3	63.5	74.7	91.5	18.7	29.9	41.1	52.3	63.5	74.7	91.5
Reach [m]	34.0	25.2													
	38.0	21.8							19.8						
	40.0		19.6												
	48.0		15.4	14.3						13.9	12.6				
	56.0			11.4	10.1						10.1	8.6			
	64.0				8.1	7.0	5.7				6.8	5.6			
	72.0				6.5	5.5	4.4				5.4	4.3	3.0		
	80.0					4.3	3.2					3.2			
88.0															
Number of falls		6	5	4	2	2	1		6	4	3	2	2	1	

7700G Load ratings



Main boom SH
with tiltable WS fly boom



105 t 40 t 67° SH		Main boom length 57.9 m							Main boom length 63.5 m						
Fly boom length		18.7	29.9	41.1	52.3	63.5	74.7	91.5	18.7	29.9	41.1	52.3	63.5	74.7	91.5
Reach [m]	38.0	17.9													
	40.0	16.8							14.4						
	48.0		12.4							10.4					
	56.0			8.8	7.0					8.4	7.0				
	64.0			7.1	5.5	4.2					5.6	4.0			
	72.0				4.3	3.0						2.9			
	80.0														
Number of falls		6	5	4	2	2	1		5	4	3	2			

105 t 40 t 67° SH		Main boom length 69.1 m						
Fly boom length		18.7	29.9	41.1	52.3	63.5	74.7	91.5
Reach [m]	42.0	11.3						
	50.0		8.0					
	58.0		6.4	5.0				
	60.0			4.7				
	66.0			3.8				
	70.0							
	80.0							
Number of falls		6	3	2				

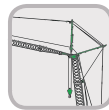

Main boom SH
with tiltable WS fly boom



105 t 40 t 50° SH		Main boom length 24.3 m							Main boom length 29.9 m						
Fly boom length		18.7	29.9	41.1	52.3	63.5	74.7	91.5	18.7	29.9	41.1	52.3	63.5	74.7	91.5
Reach [m]	34.0	28.4													
	38.0								22.6						
	42.0		21.1												
	50.0									15.1					
	58.0			12.8							11.3				
	66.0				9.4							8.1			
	74.0					6.8							5.5		
	82.0						4.5						4.3	3.2	
	90.0						3.5								
	94.0														
Number of falls		7	7	5	3	2	2		7	6	5	3	2	1	

105 t 40 t 50° SH		Main boom length 35.5 m							Main boom length 41.1 m						
Fly boom length		18.7	29.9	41.1	52.3	63.5	74.7	91.5	18.7	29.9	41.1	52.3	63.5	74.7	91.5
Reach [m]	42.0	17.9													
	50.0		13.5												
	58.0			9.9						8.7					
	66.0				5.3						6.5				
	74.0					3.2						4.0			
	82.0						2.8								
	86.0														
Number of falls		7	6	4	3	2			6	5	4	3			

Subject to change.

Table no. 7700R-80/3504/105.0/08.10 SHWS 67

Table no. 7700R-80/3504/105.0/08.10 SHWS 50

7700G Load ratings



Main boom SH
with tiltable WS fly boom



105 t 40 t 50° SH		Main boom length 46.7 m							Main boom length 52.3 m						
Fly boom length		18.7	29.9	41.1	52.3	63.5	74.7	91.5	18.7	29.9	41.1	52.3	63.5	74.7	91.5
Reach [m]	48.0	11.2													
	56.0														
	64.0								4.8						
	72.0			4.2											
	78.0														
Number of falls		6		4					4						

105 t 40 t 50° SH		Main boom length 57.9 m						
Fly boom length		18.7	29.9	41.1	52.3	63.5	74.7	91.5
Reach [m]	56.0	5.0						
	64.0		3.0					
	68.0		2.6					
Number of falls		6	4					

Table no. 7700R-80/3504/105.0/08.10 SHWS 50

7700G Load ratings



Main boom SH
with tiltable WS fly boom



135 t 40 t 87° SH		Main boom length 24.3 m							Main boom length 29.9 m						
Fly boom length		18.7	29.9	41.1	52.3	63.5	74.7	91.5	18.7	29.9	41.1	52.3	63.5	74.7	91.5
Reach [m]	10.0	95.0							92.5						
	12.0	91.5	86.3						89.4	80.1					
	14.0	88.6	81.0						86.7	76.8					
	16.0	86.0	76.2	61.4					83.7	73.1	57.1				
	18.0	78.3	71.9	58.2	36.6				75.5	69.5	54.7	33.8			
	20.0	68.2	65.6	55.2	35.8	23.7			67.0	65.8	52.4	33.1	22.7		
	24.0		54.2	50.0	34.0	22.8	14.5			54.6	48.1	31.8	21.7	14.1	
	28.0		44.4	43.9	32.3	21.8	13.9	5.9		44.4	42.7	30.6	20.8	13.6	5.1
	32.0		36.9	37.1	30.7	20.8	13.3	5.6		36.9	36.6	29.5	20.0	13.0	4.8
	36.0			31.8	29.4	19.9	12.7	5.4			31.7	28.5	19.3	12.4	4.6
	40.0			27.5	27.1	19.0	12.1	5.1			27.5	26.8	18.6	11.9	4.4
	48.0				20.8	17.5	11.1	4.6				20.8	17.4	11.0	4.0
	56.0					13.4	7.6	16.3					16.0	10.2	3.5
	64.0					12.7	9.6	3.4					12.7	9.5	3.1
	72.0						8.9	2.8						8.9	2.6
80.0															
84.0															
Number of falls		7	7	5	3	2	2	1	7	6	5	3	2	1	1

Table no. 7700R-80/3504/135.0/08.10 SHWS 87

135 t 40 t 87° SH		Main boom length 35.5 m							Main boom length 41.1 m						
Fly boom length		18.7	29.9	41.1	52.3	63.5	74.7	91.5	18.7	29.9	41.1	52.3	63.5	74.7	91.5
Reach [m]	10.0	90.0													
	12.0	87.2							83.6						
	14.0	84.7	72.7						81.4	67.3					
	16.0	82.0	70.0	52.8					79.0	64.5	48.7				
	18.0	79.0	67.0	51.2	31.0				76.5	61.9	46.8	29.5			
	20.0	75.3	63.9	49.5	30.4	21.7			73.7	59.3	45.2	29.1	20.3		
	24.0		57.5	46.2	29.5	20.6	13.8			54.0	42.3	28.0	19.5	12.8	
	28.0		48.5	43.1	28.8	19.8	13.2	4.3		47.2	39.7	27.2	18.7	12.4	4.4
	32.0		40.3	40.1	28.3	19.2	12.7	4.0		40.3	37.2	26.4	18.1	11.9	4.1
	36.0			34.6	27.7	18.7	12.2	3.8			33.3	25.6	17.4	11.4	3.9
	40.0			29.9	27.1	18.2	11.7	3.6			29.8	24.9	16.9	10.8	3.6
	48.0				22.7	17.2	10.9	3.3				22.0	15.7	9.9	3.2
	52.0				20.1	16.7	10.5	3.2				20.1	15.2	9.5	3.0
	60.0					15.7	9.8	2.9					14.2	8.7	2.7
	68.0						9.3	2.6						8.2	2.5
	72.0						9.1							7.9	
	80.0														
88.0															
Number of falls		7	6	4	3	2	1	1	6	5	4	3	2	1	1

7700G Load ratings



Main boom SH
with tiltable WS fly boom



135 t 40 t 87° SH		Main boom length 46.7 m							Main boom length 52.3 m						
Fly boom length		18.7	29.9	41.1	52.3	63.5	74.7	91.5	18.7	29.9	41.1	52.3	63.5	74.7	91.5
Reach [m]	10.0								76.7						
	12.0	80.0													
	14.0	78.0	61.8						73.3	57.0					
	16.0	76.0	59.0	44.6					68.3	54.3	40.7				
	18.0	74.0	56.7	42.4					67.0	52.0	38.7	25.8			
	20.0	72.0	54.7	40.8	27.7				64.9	49.8	37.2	25.5			
	24.0		50.4	38.4	26.6	18.5				45.6	34.8	24.3			
	28.0		45.8	36.4	25.5	17.7	11.5	4.5		39.9	31.9	23.2			
	32.0		42.1	34.3	24.5	17.0	11.0	4.2		38.9	30.9	22.2			
	36.0			31.9	23.6	16.2	10.5	3.9			29.0	21.3			
	40.0			29.7	22.7	15.5	10.0	3.6			27.0	20.5			
	48.0				21.3	14.2	8.9	3.1				19.1	12.9	8.2	3.0
	52.0				20.7	13.7	8.3	2.9				18.5	12.4	7.7	2.7
	60.0					12.7	7.7	2.6					11.4	6.9	
	68.0						7.1							6.2	
76.0						6.4							5.4		
84.0															
Number of falls		6	5	4	2	2	1	1	6	5	3	2	2	1	1

135 t 40 t 87° SH		Main boom length 57.9 m							Main boom length 63.5 m						
Fly boom length		18.7	29.9	41.1	52.3	63.5	74.7	91.5	18.7	29.9	41.1	52.3	63.5	74.7	91.5
Reach [m]	10.0								63.7						
	12.0	73.5													
	14.0	68.5	52.2						58.8	44.7					
	16.0	63.5	49.7						55.1	42.7					
	18.0	60.0	47.2						52.5	40.5	30.2				
	20.0	57.8	44.9	33.6	23.2				50.3	38.7	28.5	20.1			
	24.0	48.0	40.8	31.2	22.0	16.4			43.0	35.6	26.3	18.4	14.1		
	28.0		37.6	29.3	21.0	15.7	10.4	4.5		32.9	24.7	17.0	13.1	8.8	
	32.0		34.4	27.6	20.0	14.8	9.8	4.3		30.1	23.3	15.8	12.1	8.2	
	36.0			26.0	19.1	13.9	9.2	3.9			21.8	14.8	11.1	7.6	
	40.0			24.4	18.2	13.0	8.6	3.5			20.4	13.9	10.2	7.0	
	48.0				16.9	11.6	7.5	2.8				12.6	8.8	5.9	
	52.0				16.4	11.0	7.0	2.6				12.1	8.3	5.4	
	60.0					10.2	6.1						7.4	4.6	
	68.0					8.8	5.3						6.3	3.9	
76.0						4.3							3.2		
84.0															
Number of falls		6	4	3	2	2	1	1	5	4	3	2	1	1	

Table no. 7700R-80/3504/135.0/08.10 SHWS 87

135 t 40 t 87° SH		Main boom length 69.1 m							Main boom length 74.7 m							
Fly boom length		18.7	29.9	41.1	52.3	63.5	74.7	91.5	18.7	29.9	41.1	52.3	63.5	74.7	91.5	
Reach [m]	10.0															
	12.0	54.0							44.0							
	14.0	49.0							42.5							
	16.0	46.7	35.8						40.5	31.3						
	18.0	45.0	33.8	25.3					38.7	29.8	22.3					
	20.0	42.8	32.5	23.5	17.0				37.5	28.3	21.0	15.0				
	24.0	38.0	30.4	21.3	14.7	11.8			35.0	25.8	18.8	13.0	9.6			
	28.0		28.1	20.0	13.0	10.5	7.2			24.6	17.2	11.6	8.7	6.3		
	32.0		25.9	18.9	11.6	9.3	6.5			23.7	16.0	10.5	7.9	5.9		
	36.0			17.7	10.5	8.3	5.9				15.0	9.6	7.2	5.4		
	40.0			16.4	9.7	7.4	5.3				14.2	8.8	6.6	4.8		
	48.0				8.4	6.0	4.3					7.3	5.4	3.7		
	52.0				7.8	5.5	3.9					6.6	4.9	3.1		
	60.0					4.7	3.1						3.9			
68.0					3.9							2.8				
76.0																
Number of falls		6	4	3	2	2	1	1	5	4	3	2	1	1		



**Main SH boom
with tiltable WS fly boom**



135 t 40 t 82° SH		Main boom length 24.3 m							Main boom length 29.9 m							
Fly boom length		18.7	29.9	41.1	52.3	63.5	74.7	91.5	18.7	29.9	41.1	52.3	63.5	74.7	91.5	
Reach [m]	13.0	95.0														
	15.0	91.0							93.0							
	17.0	87.0	70.0						87.4							
	19.0	84.0	65.2						81.4	65.2						
	20.0	79.9	63.3	51.3					77.5	63.3						
	24.0	60.0	57.3	45.9	33.0				61.1	57.3	46.3	31.5				
	28.0		49.5	42.3	31.8	21.2				49.5	43.5	30.6	20.5			
	32.0		40.8	39.5	30.5	20.4	13.1			40.8	40.4	29.6	19.9	13.0		
	36.0			34.6	29.2	19.6	12.5				35.6	28.5	19.2	12.5		
	40.0			29.8	28.0	18.9	11.9	5.6			30.9	27.5	18.5	11.9	5.2	
	48.0				22.3	17.6	10.9	4.6				22.3	17.2	10.9	4.4	
	56.0				17.4	16.3	10.0	3.8				17.4	15.9	10.0	3.7	
	64.0					13.6	9.2	3.3					13.6	9.2	3.1	
	72.0						8.5	2.7						8.5	2.6	
80.0																
88.0																
Number of falls		7	7	5	3	2	2	1	7	6	5	3	2	1	1	

Table no. 7700R-80/3504/135.0/08.10 SHWS 82

135 t 40 t 82° SH		Main boom length 35.5 m							Main boom length 41.1 m							
Fly boom length		18.7	29.9	41.1	52.3	63.5	74.7	91.5	18.7	29.9	41.1	52.3	63.5	74.7	91.5	
Reach [m]	15.0	95.0														
	19.0	78.8	67.6						75.4	64.4						
	20.0	75.0	67.2						71.8	64.4						
	24.0	62.3	59.1	46.7					60.0	58.5	44.3					
	28.0		50.8	44.6	30.0					48.9	41.6	28.2				
	32.0		43.2	41.2	29.5					42.2	38.4	27.1	18.3			
	36.0		37.4	36.5	28.6	19.4	12.9			36.8	34.9	26.1	17.5	11.5		
	40.0			32.0	27.8	18.8	12.5				31.5	25.1	16.7	11.0	4.4	
	48.0			25.2	26.1	17.4	11.6	4.4			24.9	22.9	15.2	10.0	3.9	
	56.0				21.9	16.1	10.7	3.9				19.3	14.1	9.1	3.6	
	64.0					15.0	9.8	3.5					13.4	8.3	3.2	
	72.0					13.7	9.1	3.0					10.2	7.7	2.7	
	80.0						8.6	2.5						7.2		
	88.0															
92.0																
Number of falls		7	6	4	3	2	1	1	6	5	4	3	2	1	1	

7700G Load ratings



Main boom SH
with tiltable WS fly boom



135 t 40 t 82° SH		Main boom length 46.7 m							Main boom length 52.3 m						
Fly boom length		18.7	29.9	41.1	52.3	63.5	74.7	91.5	18.7	29.9	41.1	52.3	63.5	74.7	91.5
Reach [m]	16.0	84.7													
	18.0	75.8							72.3						
	20.0	68.6	61.6						65.5						
	24.0	57.8	54.0	42.0					55.2	50.6	38.2				
	28.0		47.0	38.5	27.0					44.9	35.6	24.5			
	32.0		41.3	35.7	25.5	17.2				39.6	32.8	22.7	16.0		
	36.0		36.2	33.2	24.3	16.1	10.6			35.0	30.5	21.3	15.0	10.1	
	40.0			30.9	23.3	15.2	9.9	4.0			28.1	20.2	14.1	9.6	3.8
	48.0			24.6	21.4	13.7	8.8	3.7			22.9	18.2	12.6	8.6	3.5
	56.0				19.1	12.7	7.9	3.4				16.1	11.5	7.9	3.2
	64.0					12.0	7.2	3.2					10.7	7.2	3.0
	72.0						6.6	2.8					9.1	6.6	2.7
80.0						5.9	2.5						5.9	2.5	
92.0															
Number of falls		6	5	4	2	2	1	1	6	5	3	2	2	1	1

135 t 40 t 82° SH		Main boom length 57.9 m							Main boom length 63.5 m						
Fly boom length		18.7	29.9	41.1	52.3	63.5	74.7	91.5	18.7	29.9	41.1	52.3	63.5	74.7	91.5
Reach [m]	18.0	68.7													
	20.0	62.4							57.4						
	24.0	52.7	47.1						48.6	42.3					
	28.0	45.8	42.8	32.6	22.0				43.1	38.0	29.4				
	32.0		37.9	29.9	19.8	14.7				33.7	26.8	18.4			
	36.0		33.8	27.7	18.3	13.8	9.5			30.6	24.4	16.6	12.3	8.4	
	40.0		30.6	25.4	17.0	12.9	9.2			28.0	22.2	15.2	11.4	8.1	
	48.0			21.2	15.0	11.5	8.5	3.3			18.5	12.8	9.8	7.2	
	56.0				13.1	10.4	7.8	3.0				10.5	8.5	6.3	
	64.0					9.4	7.2	2.8					7.2	5.4	
	72.0					8.4	6.6	2.6					6.1	4.6	
	80.0						6.1							3.9	
88.0															
92.0															
Number of falls		6	4	3	2	2	1	1	5	4	3	2	1	1	

135 t 40 t 82° SH		Main boom length 69.1 m							Main boom length 74.7 m						
Fly boom length		18.7	29.9	41.1	52.3	63.5	74.7	91.5	18.7	29.9	41.1	52.3	63.5	74.7	91.5
Reach [m]	20.0	52.2							42.0						
	24.0	44.5	37.4						38.0	31.0					
	28.0	40.5	33.2	26.2					34.2	28.4	21.9				
	32.0		29.6	23.6	16.9					26.1	20.2	14.0			
	36.0		27.3	21.1	15.0	10.8				24.1	18.8	13.0	9.5		
	40.0		25.3	19.0	13.4	9.8	7.0			22.3	17.4	12.0	8.8	5.8	
	48.0			15.9	10.6	8.1	5.9				14.9	10.0	7.3	4.8	
	56.0				8.0	6.6	4.8					8.0	6.0	3.6	
	64.0					5.0	3.7					5.5	4.7	2.5	
	72.0					3.7	2.6						3.2		
76.0															
Number of falls		4	3	2	2	1	1		4	3	2	2	1	1	

Table no. 7700R-80/3504/135.0/08.10 SHWS 82

7700G Load ratings



Main boom SH
with tiltable WS fly boom



135 t 40 t 77° SH		Main boom length 24.3 m							Main boom length 29.9 m						
Fly boom length		18.7	29.9	41.1	52.3	63.5	74.7	91.5	18.7	29.9	41.1	52.3	63.5	74.7	91.5
Reach [m]	17.0	93.5													
	19.0	83.5							79.4						
	20.0	78.2							74.9						
	24.0	62.2	61.5						61.0	59.0					
	28.0		50.8	47.6						49.6	46.6				
	32.0		43.1	42.2	33.1					42.2	41.0	31.5			
	36.0		37.3	36.5	31.3	23.2				36.5	35.6	30.3	22.6		
	40.0			32.0	29.7	22.0	15.3				31.2	29.2	21.7	15.1	
	48.0			24.2	23.9	19.7	13.7	5.8			24.2	23.5	19.6	13.6	5.4
	56.0				18.6	17.4	12.0	5.0				18.7	17.5	12.0	4.7
	64.0					14.5	10.3	4.4					14.5	10.3	4.1
	72.0						8.8	3.8						8.8	3.6
	80.0						7.8	3.4						7.7	3.0
88.0							3.0							2.5	
96.0							2.6								
Number of falls		7	7	5	3	2	2	1	7	6	5	3	2	1	1

Table no. 7700R-80/3504/135.0/08.10 SHWS 77

135 t 40 t 77° SH		Main boom length 35.5 m							Main boom length 41.1 m						
Fly boom length		18.7	29.9	41.1	52.3	63.5	74.7	91.5	18.7	29.9	41.1	52.3	63.5	74.7	91.5
Reach [m]	19.0	75.4													
	20.0	71.7													
	24.0	59.8	56.5							56.7					
	28.0	49.4	48.4	45.7						47.7	46.1				
	32.0		41.3	39.9	30.0						39.9	38.0			
	36.0		35.7	34.7	29.3						34.8	33.3	28.7		
	40.0		31.4	30.5	28.6	21.3					30.5	29.5	27.6	19.6	
	48.0			24.2	23.0	19.4	13.5	5.0			23.5	22.2	17.7	12.1	
	56.0				18.7	17.6	12.0	4.4				18.0	15.7	10.7	3.8
	64.0					14.6	10.6	3.9					13.5	9.5	3.5
	72.0					12.2	9.1	3.3					11.7	8.4	3.1
	80.0						7.7	2.7						7.3	2.7
	88.0														
96.0															
Number of falls		7	6	4	3	2	1	1	6	5	4	3	2	1	1

7700G Load ratings



Main boom SH
with tiltable WS fly boom



135 t 40 t 77° SH		Main boom length 46.7 m							Main boom length 52.3 m							
Fly boom length		18.7	29.9	41.1	52.3	63.5	74.7	91.5	18.7	29.9	41.1	52.3	63.5	74.7	91.5	
Reach [m]	22.0	58.3														
	26.0	49.5	47.1						47.0							
	32.0		38.4	36.0					38.3	36.3	33.8					
	36.0		33.8	31.9	28.0					32.1	30.1	24.3				
	40.0		29.7	28.6	26.5	17.8				28.5	27.0	23.4				
	48.0			22.7	21.5	15.9	10.7				21.8	20.0	15.2	10.6		
	56.0				17.4	13.9	9.5	3.3				16.6	13.2	9.4		
	64.0				14.4	12.5	8.5	3.1				13.8	11.8	8.3		
	72.0					11.2	7.6	2.9					10.6	7.4		
	80.0						6.9	2.7						6.8		
	88.0							2.5							6.1	
96.0																
Number of falls		6	5	4	2	2	1	1	6	5	3	2	2	1		

135 t 40 t 77° SH		Main boom length 57.9 m							Main boom length 63.5 m							
Fly boom length		18.7	29.9	41.1	52.3	63.5	74.7	91.5	18.7	29.9	41.1	52.3	63.5	74.7	91.5	
Reach [m]	24.0	47.9														
	28.0	41.3							38.7							
	36.0		30.4	28.3						28.4	26.4					
	40.0		27.3	25.4	20.4					25.5	23.6	18.7				
	48.0			20.8	18.5	14.5	10.5				19.4	16.2	12.4	8.0		
	56.0			17.1	15.7	12.6	9.2				16.1	13.4	10.5	7.2		
	64.0				13.1	11.1	8.1					10.7	9.0	6.2		
	72.0					10.0	7.2						7.9	5.4		
	80.0						6.6							4.8		
	88.0						6.1									
	92.0															
Number of falls		6	4	3	2	2	1		5	4	3	2	1	1		

135 t 40 t 77° SH		Main boom length 69.1 m							Main boom length 74.7 m							
Fly boom length		18.7	29.9	41.1	52.3	63.5	74.7	91.5	18.7	29.9	41.1	52.3	63.5	74.7	91.5	
Reach [m]	28.0	36.1							33.4							
	32.0	31.7	29.8						29.4							
	36.0	28.4	26.5	24.5					26.2	24.4						
	40.0		23.8	21.9						21.9	19.7					
	48.0			18.0	14.5	10.4				18.1	16.4	11.0				
	56.0			15.1	11.3	8.4					13.7	9.0				
	64.0				8.7	6.9						7.0				
	72.0					5.8										
	80.0					4.8										
	84.0															
Number of falls		4	3	2	2	1			4	3	2	2				

Table no. 7700R-80/3504/135.0/08.10 SHWS 77

7700G Load ratings



Main boom SH
with tiltable WS fly boom



135 t 40 t 67° SH		Main boom length 24.3 m							Main boom length 29.9 m						
Fly boom length		18.7	29.9	41.1	52.3	63.5	74.7	91.5	18.7	29.9	41.1	52.3	63.5	74.7	91.5
Reach [m]	24.0	59.3													
	28.0	48.9							47.2						
	32.0		40.9						39.9	39.3					
	36.0		35.4	34.4						34.0					
	40.0		31.0	30.1						29.8	28.8				
	48.0			23.9	22.7	18.4					22.8	21.6			
	56.0				18.4	15.6	10.0					17.5	15.5	10.3	
	58.0				17.6	15.0	9.8					16.6	14.8	10.0	
	64.0					13.7	8.9	3.0				14.4	13.0	9.2	
	72.0					12.0	7.9	2.8					11.2	7.9	
	80.0						7.3	2.6						7.2	
	88.0							2.5							
96.0															
Number of falls		7	7	5	3	2	2	1	7	6	5	3	2	1	

135 t 40 t 67° SH		Main boom length 35.5 m							Main boom length 41.1 m						
Fly boom length		18.7	29.9	41.1	52.3	63.5	74.7	91.5	18.7	29.9	41.1	52.3	63.5	74.7	91.5
Reach [m]	28.0	45.4													
	32.0	38.5							36.7						
	36.0		32.6						31.6	30.9					
	40.0		28.5	27.4						27.1					
	48.0			21.7	20.4						20.4				
	56.0			17.7	16.5	15.4					16.6	15.3	14.1		
	64.0				13.6	12.4	9.7					12.6	11.5	9.6	
	80.0						7.1						7.8	6.6	
	88.0						6.4							5.6	
	96.0														
Number of falls		7	6	4	3	2	1		6	5	4	3	2	1	

Table no. 7700R-80/3504/135.0/08:10 SHWS 67

7700G Load ratings



Main boom SH
with tiltable WS fly boom



135 t 40 t 67° SH		Main boom length 46.7 m							Main boom length 52.3 m						
Fly boom length		18.7	29.9	41.1	52.3	63.5	74.7	91.5	18.7	29.9	41.1	52.3	63.5	74.7	91.5
Reach [m]	34.0	32.3													
	38.0	28.1							26.3						
	40.0		25.6												
	44.0		22.7							21.1					
	48.0		20.3	19.2						18.8	17.6				
	52.0			17.2	15.8					16.9	15.8				
	60.0			14.2	12.8	11.7					13.0	11.6	10.3		
	68.0				10.6	9.5	8.4					9.5	8.4	5.9	
	76.0					7.8	6.8						6.8	5.3	
	84.0						5.5							5.6	4.5
	92.0						4.4								3.5
Number of falls		6	5	4	2	2	1		6	5	3	2	2	1	

135 t 40 t 67° SH		Main boom length 57.9 m							Main boom length 63.5 m						
Fly boom length		18.7	29.9	41.1	52.3	63.5	74.7	91.5	18.7	29.9	41.1	52.3	63.5	74.7	91.5
Reach [m]	38.0	24.5													
	40.0	22.9								20.6					
	44.0		19.5							18.3					
	48.0		17.4								15.5				
	52.0		15.6	14.4							14.0	12.6			
	60.0			11.8	10.3							10.3	8.7		
	68.0				8.4	7.2							7.0	5.3	
	76.0					7.0	5.8						5.7	4.2	
	84.0						4.7							3.3	
	92.0														
Number of falls		6	4	3	2	2			5	4	3	2	1		

135 t 40 t 67° SH		Main boom length 69.1 m							Main boom length 74.7 m						
Fly boom length		18.7	29.9	41.1	52.3	63.5	74.7	91.5	18.7	29.9	41.1	52.3	63.5	74.7	91.5
Reach [m]	42.0	17.2													
	50.0		12.9							12.0	10.8				
	58.0		10.8	9.2							8.9	7.4			
	64.0			8.0	6.3							6.3			
	72.0					5.0						5.2			
	80.0					4.0									
Number of falls		4	3	2	2				4	3	2				

Table no. 7700R-80/3504/135.0/08.10 SHWS 67

7700G Load ratings



Main boom SH
with tiltable WS fly boom



135 t 40 t 50° SH		Main boom length 24.3 m							Main boom length 29.9 m						
Fly boom length		18.7	29.9	41.1	52.3	63.5	74.7	91.5	18.7	29.9	41.1	52.3	63.5	74.7	91.5
Reach [m]	34.0	35.5													
	38.0								28.9						
	42.0		26.7												
	50.0									19.8					
	58.0			16.7							15.3				
	66.0				12.9							11.5			
	74.0					9.8							8.6		
	82.0						7.3						7.1	6.0	
	90.0						5.6							4.7	
98.0															
102.0															
Number of falls		7	7	5	3	2	2	7	7	6	5	3	2	1	7

135 t 40 t 50° SH		Main boom length 35.5 m							Main boom length 41.1 m						
Fly boom length		18.7	29.9	41.1	52.3	63.5	74.7	91.5	18.7	29.9	41.1	52.3	63.5	74.7	91.5
Reach [m]	42.0	23.5													
	50.0		18.1												
	58.0			13.8						12.7					
	66.0										10.0				
	74.0				8.4							7.0			
	82.0					6.0							4.4		
	90.0						3.9								
	98.0						3.0								
Number of falls		7	6	4	3	2	1	7	7	5	4	3	2	7	7

135 t 40 t 50° SH		Main boom length 46.7 m							Main boom length 52.3 m						
Fly boom length		18.7	29.9	41.1	52.3	63.5	74.7	91.5	18.7	29.9	41.1	52.3	63.5	74.7	91.5
Reach [m]	48.0	16.0													
	56.0														
	64.0									8.3					
	72.0			7.4							5.7				
	80.0				4.8										
	82.0				4.5										
Number of falls		6	6	4	2			6	6	5	3			6	6

135 t 40 t 50° SH		Main boom length 57.9 m						
Fly boom length		18.7	29.9	41.1	52.3	63.5	74.7	91.5
Reach [m]	56.0	9.1						
	58.0	8.6						
	60.0							
	62.0							
	64.0		6.6					
	66.0		6.2					
	68.0		5.9					
	70.0							
Number of falls		6	4					6

Table no. 7700R-80/3504/135.0/08.10 SHWS 50

7700G Boom configuration

Main boom SH

Boom length [m]		Main boom													
		18.7	24.3	29.9	35.5	41.1	46.7	52.3	57.9	63.5	69.1	74.7	80.3	85.9	91.5
Lower SH boom section type 2409	7.0 m	1	1	1	1	1	1	1	1	1	1	1	1	1	1
SH boom section type 2409-V	5.6 m	1	0	1	0	1	0	1	0	1	0	1	0	1	0
SH boom section type 2409-V	11.2 m	0	1	1	2	2	2	2	2	2	2	2	2	2	2
SH boom section type 2409	11.2 m	0	0	0	0	0	1	1	2	2	3	3	4	4	5
Conical SH boom section type 2409	4.6 m	1	1	1	1	1	1	1	1	1	1	1	1	1	1
T300/200 pulley head	1.5 m	1	1	1	1	1	1	1	1	1	1	1	1	1	1
S42.1 auxiliary boom (optional)	42.0 t	x	x	x	x	x	x	x	x	x	x	x	x	x	x

Main boom SHLH

Boom length [m]		Main boom								
		69.1	74.7	80.3	85.9	91.5	97.1	102.7	108.3	113.9
Lower SH boom section type 2409	7.0 m	1	1	1	1	1	1	1	1	1
SH boom section type 2409-V	5.6 m	1	1	1	1	1	1	1	1	1
SH boom section type 2409-V	11.2 m	2	2	2	2	2	2	2	2	2
SH boom section type 2409	11.2 m	2	2	2	2	2	2	2	2	2
Conical SH boom section type 2409	4.6 m	1	1	1	1	1	1	1	1	1
LH boom section type 2002	5.6 m	0	1	0	1	0	1	0	1	0
LH boom section type 2002	11.2 m	0	0	1	1	2	2	3	3	4
LH/T110 head piece type 2002	7.1 m	1	1	1	1	1	1	1	1	1
S42.1 auxiliary boom (optional)	42.0 t	x	x	x	x	x	x	x	x	x

SHWS tiltable jib (Main boom SH with tiltable WS fly boom)

Boom length [m]		Main boom										Fly boom													
		24.3	29.9	35.5	41.1	46.7	52.3	57.9	63.5	69.1	74.7	18.7	24.3	29.9	35.5	41.1	46.7	52.3	57.9	63.5	69.1	74.7	80.3	85.9	91.5
Lower SH boom section type 2409	7.0 m	1	1	1	1	1	1	1	1	1	1														
SH boom section type 2409-V	5.6 m	0	1	0	1	0	1	0	1	0	1														
SH boom section type 2409-V	11.2 m	1	1	2	2	2	2	2	2	2	2														
SH boom section type 2409	11.2 m	0	0	0	0	1	1	2	2	3	3														
Conical SH boom section type 2409	4.6 m	1	1	1	1	1	1	1	1	1	1														
T300/200 pulley head	1.5 m	1	1	1	1	1	1	1	1	1	1														
LH fly boom lower section type 2002	11.6 m											1	1	1	1	1	1	1	1	1	1	1	1	1	1
LH boom section type 2002	5.6 m											0	1	0	1	0	1	0	1	0	1	0	1	0	1
LH boom section type 2002	11.2 m											0	0	1	1	2	2	3	3	4	4	5	5	6	6
LH/T110 head piece type 2002	7.1 m											1	1	1	1	1	1	1	1	1	1	1	1	1	1
S42.1 auxiliary boom (optional)	42 t											x	x	x	x	x	x	x	x	x	x	x	x	x	x

Combination options											
Fly boom length	18.7 m	x	x	x	x	x	x	x	x	x	x
	24.3 m	x	x	x	x	x	x	x	x	x	x
	29.9 m	x	x	x	x	x	x	x	x	x	x
	35.5 m	x	x	x	x	x	x	x	x	x	x
	41.1 m	x	x	x	x	x	x	x	x	x	x
	46.7 m	x	x	x	x	x	x	x	x	x	x
	52.3 m	x	x	x	x	x	x	x	x	x	x
	57.9 m	x	x	x	x	x	x	x	x	x	x
	63.5 m	x	x	x	x	x	x	x	x	x	x
	69.1 m	x	x	x	x	x	x	x	x	x	x
	74.7 m	x	x	x	x	x	x	x	x	x	x
	80.3 m	x	x	x	x	x	x	x	x	x	
	85.9 m	x	x	x	x	x	x	x	x		
	91.5 m	x	x	x	x	x	x	x			

7700G Transport dimensions and weights

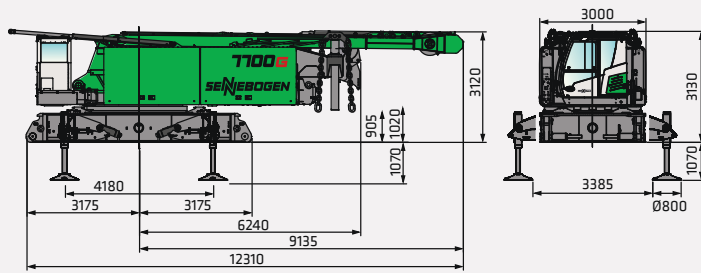

Basic machine without lower boom section
55 t incl. hoisting gear I + II, 650 m hoist cable, ballast support
46 t without hoisting gears, without ballast support

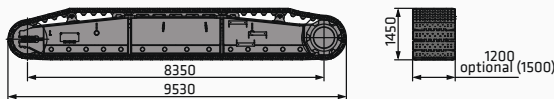

Crawler drive: 2 x
1200 mm (option: 1500 mm) flat track shoes
Weight: 23000 kg (option 1500 mm: 24500 kg)

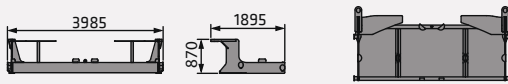

Console undercarriage ballast
Weight: 900 kg 2 x

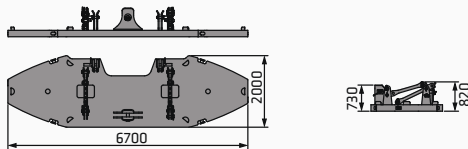

Ballast base plate
Weight: 15000 kg 1 x

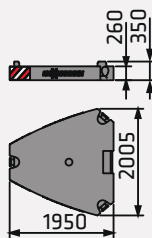

Counter weight	Uppercarriage ballast	
Weight: 5000 kg	85 t	14 x
	105 t	18 x
	135 t	24 x
	Undercarriage ballast	
	40 t	8 x

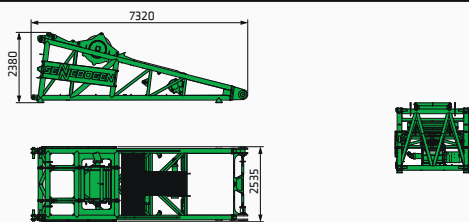

SH boom lower section 7 m type 2409
Weight: 7500 kg (incl. shifting winch WS and cable)
4700 kg (without shifting winch WS and cable) Width: 2460 mm

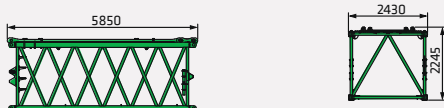

5.6 m SH boom section type 2409-V with SH/SHWS guying)
Weight: 2080 / 2280 kg

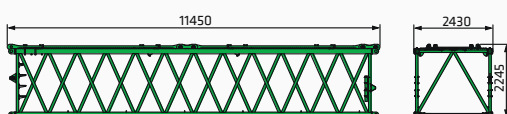

11.2 m SH boom section type 2409 with SH/SHWS guying)
Weight: 3400 / 3800 kg

7700G Transport dimensions and weights

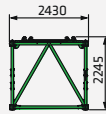
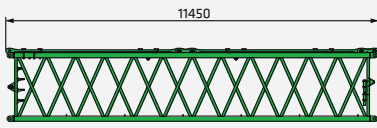

**11.2 m SH boom section type 2409-V
with SH/SHWS guying)**

Weight: 3780 / 4180 kg

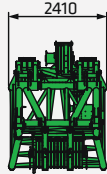
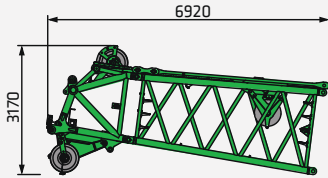

**6.1 m SH boom head piece type 2409 (with guying)
= 4.6 m SH cone + 1.5 m T300 pulley head**

Weight: max. 5500 kg (incl. Roller block)

Width: 2410 mm

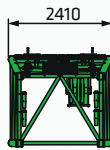
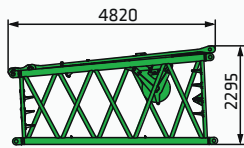

**4.6 m SH boom cone type 2409
(with guying)**

Weight: 2100 kg (incl. Roller block)

Width: 2410 mm

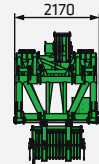
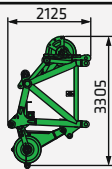

1.5 m T300 pulley head (with guying)

Weight: 3400 kg

Width: 2200 mm

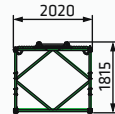
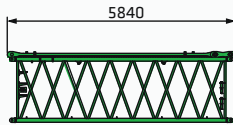

**5.6 m LH boom section type 2002
(with guying)**

Weight: 970 kg

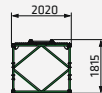
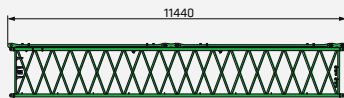

**11.2 m LH boom section type 2002
(with guying)**

Weight: 1750 kg

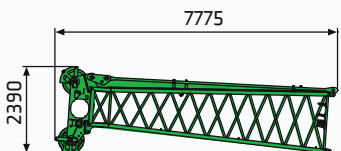

**7.1 m LH boom head piece type 2002
(with guying)**

Weight: 1940 kg

Width: 2010 mm

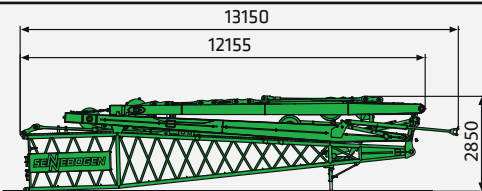

**11.6 m WS lower boom section type 2002
(with two guying frames)**

Weight: 9100 kg

Width: 2440 mm

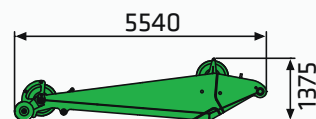

542.1 auxiliary boom (42 t)

Weight: 1300 kg

Load capacity: 42.0 t

7700G Transport measurements and weights

	<p>Set-up aid for long booms Weight: 1250 kg</p>	<p>2 x</p>
	<p>5.6 m SH boom section type 2409-V incl. 5.6 m LH type 2002 with guying SH/SHWS Weight: 3050/3250 kg</p>	
	<p>11.2 m SH boom section type 2409-V incl. 11.2 m LH type 2002 with guying SH/SHWS Weight: 5530/5930 kg</p>	
	<p>11.2 m SH boom section type 2409 incl. 11.2 m LH type 2002 with guying SH/SHWS Weight: 5150/5550 kg</p>	
	<p>300 t hook block - 11 rollers Weight: 3300/4500 kg Width: 1240/1470 mm</p>	
	<p>200 t hook block - 7 rollers Weight: 1800/3000/4200 kg Width: 940/1200/1460 mm</p>	
	<p>150 t hook block - 5 rollers Weight: 1600/2800/4000 kg Width: 940/1200/1460 mm</p>	
	<p>100 t hook block - 3 rollers Weight: 1400/2200/3000 kg Width: 540/720/900 mm</p>	
	<p>50 t hook block - 1 roller Weight: 1000/1800 kg Width: 460/570 mm</p>	
	<p>15 t loading hook Weight: 900 kg Width: 500 mm</p>	

7700G Basic machine dimensions and weights

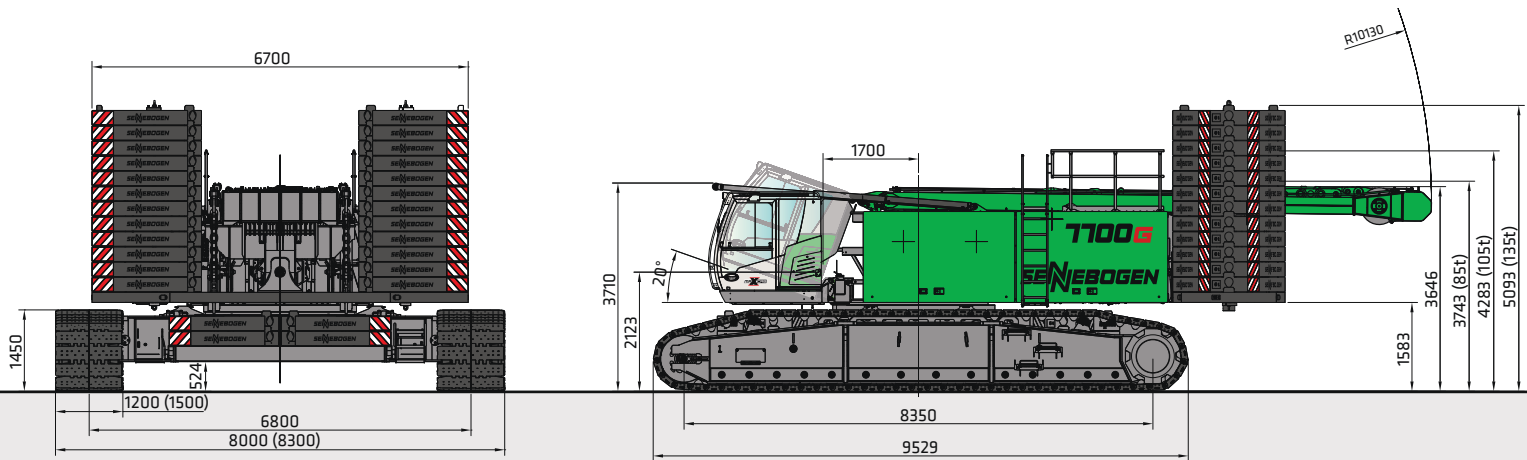

Weight: approx. 278 t consisting of basic machine with 135 t counterweight, 40 t undercarriage ballast, 1200 mm flat track shoes, ballast support, hoisting gear 1+2 with 650 m hoist cable

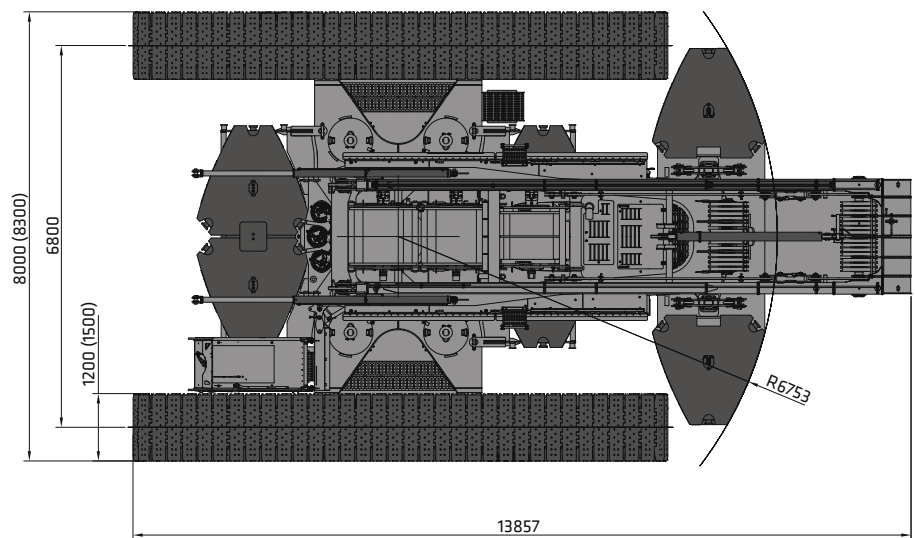

T100G Self-assembly system

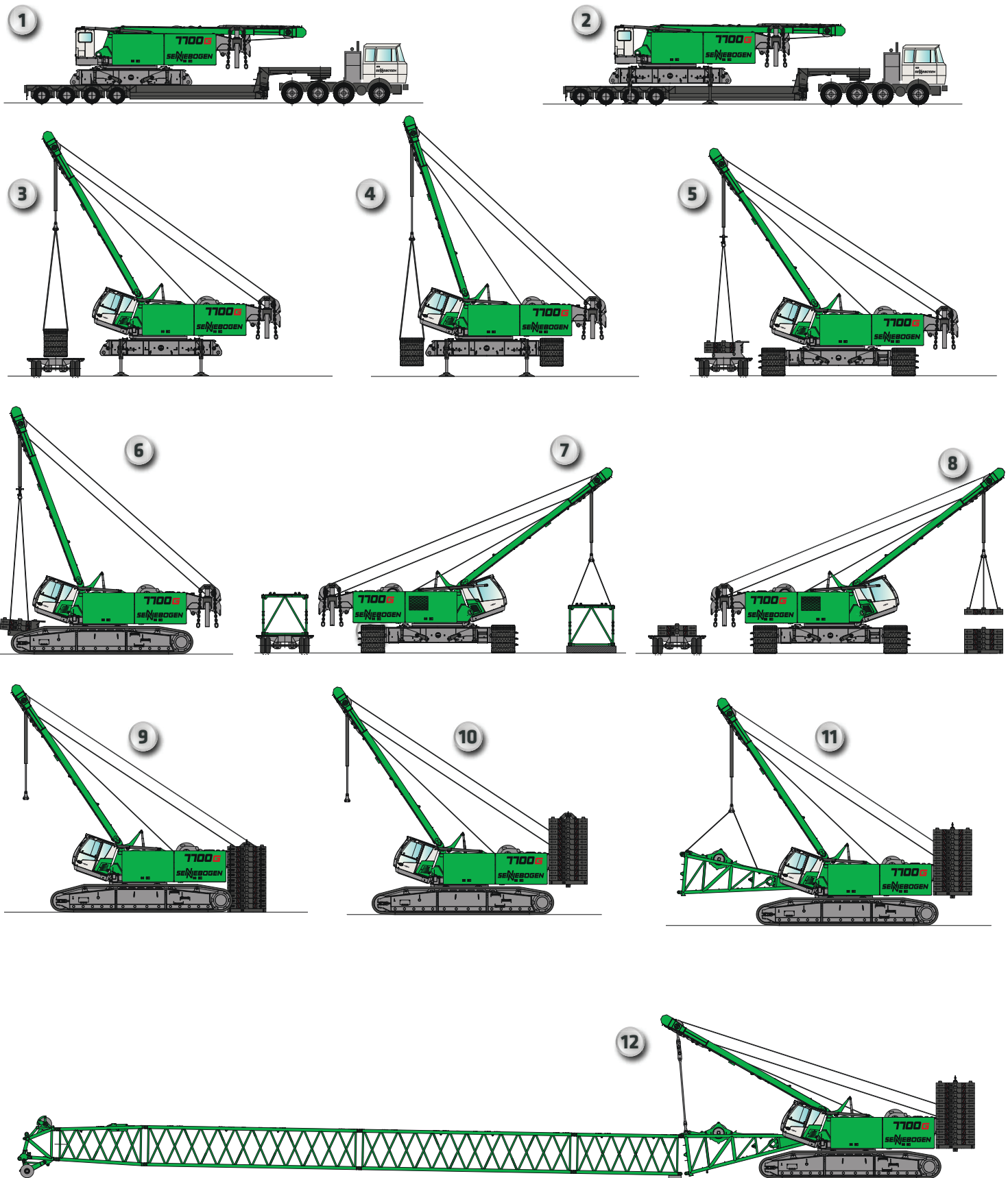

7700G Hoisting the SHWS boom

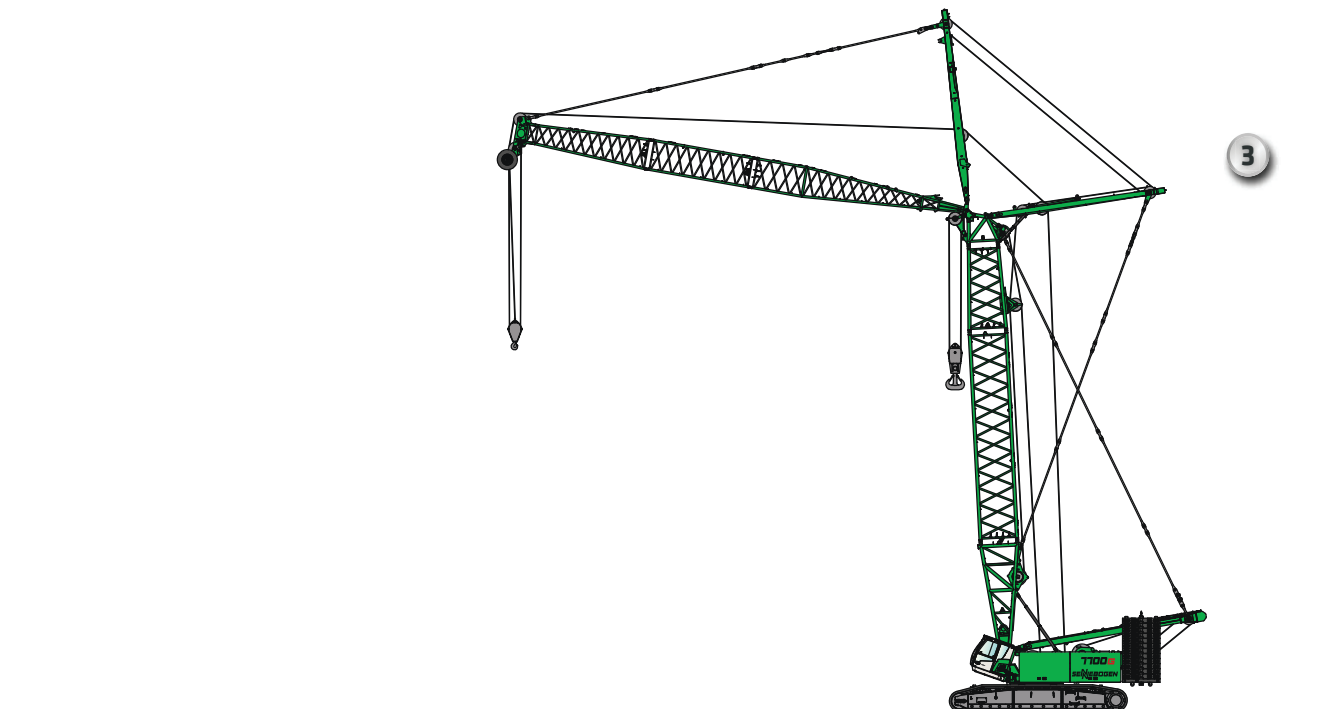
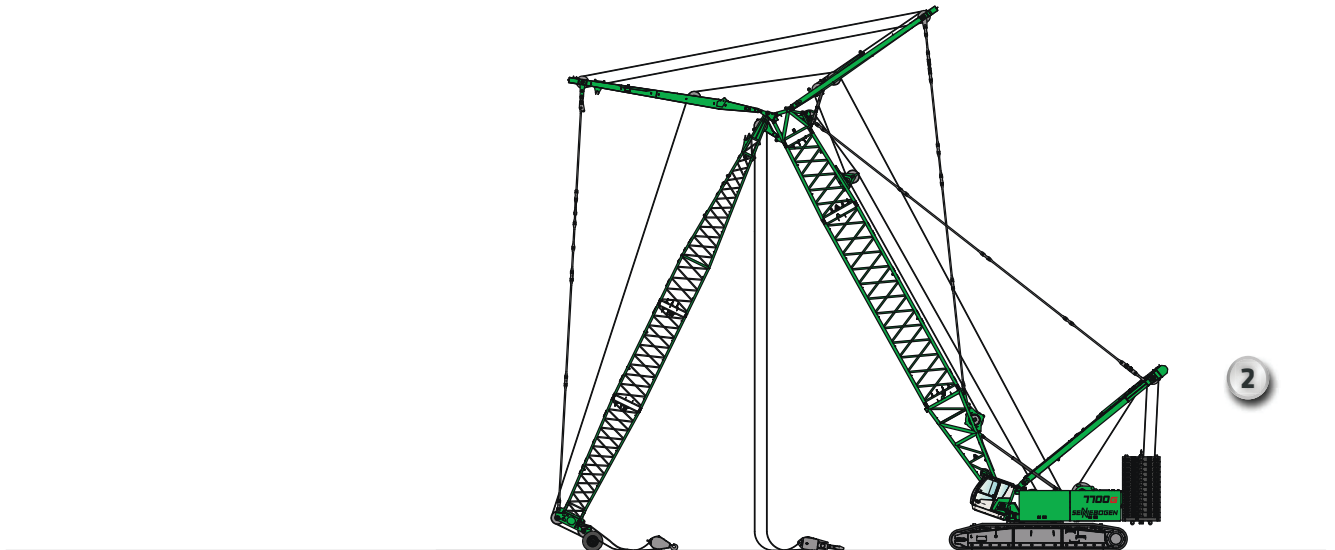
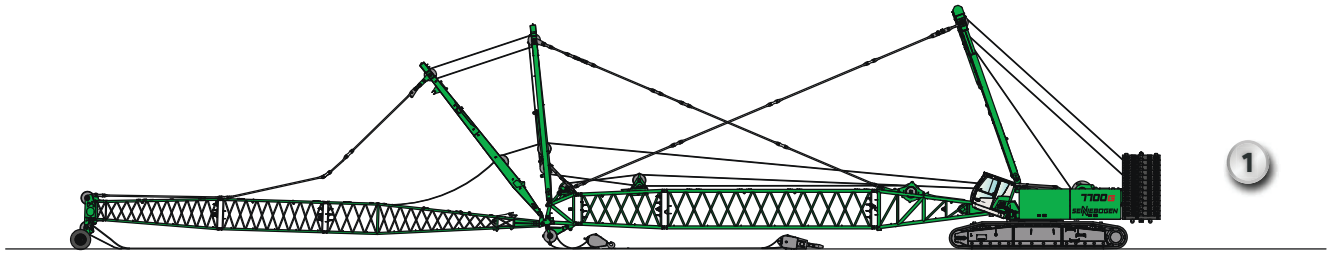

7700G

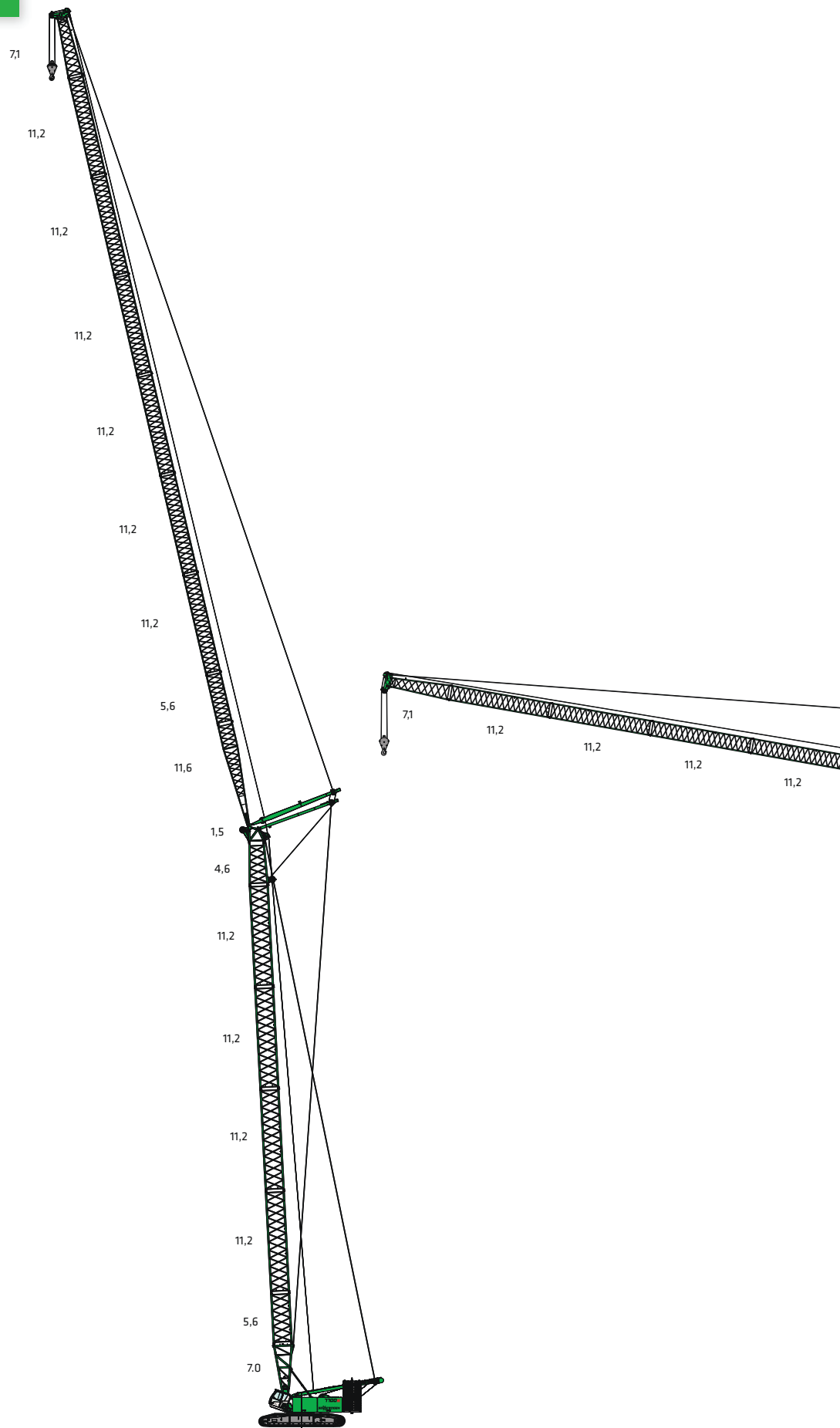

SH + WS



SH + WS

SH

SH + LH

7700G



This catalog describes machine models, scope of equipment of individual models, and configuration options (standard equipment and optional equipment) of the machines delivered by SENNEBOGEN Maschinenfabrik GmbH. Machine illustrations can contain optional equipment and supplemental equipment. Actual equipment may vary depending on the country to which the machines are delivered, especially in regard to standard and optional equipment and tolerances.

All product designations used may be trademarks of SENNEBOGEN Maschinenfabrik GmbH or other supplying companies, and any use by third parties for their own purposes may violate the rights of the owners.

Please contact your local SENNEBOGEN sales partner for information concerning the equipment variants offered. Requested performance characteristics are only binding if they are expressly stipulated upon conclusion of the contract. Delivery options and technical features are subject to change. All information is supplied without liability. Equipment is subject to change, and rights of advancement are reserved.

© SENNEBOGEN Maschinenfabrik GmbH, Straubing, Germany. Reproduction in whole or in part only with written consent of SENNEBOGEN Maschinenfabrik GmbH, Straubing, Germany.



SENNEBOGEN
Maschinenfabrik GmbH
Sennebogenstraße 10
94315 Straubing, Germany

Tel. +49 9421 540-144/146
marketing@sennebogen.de

Order no. 299256
7700-G-011910