



## Preface

Dear user,

This operating manual provides the user of the Spierings folding crane with information concerning the crane's construction and operation. You will find detailed technical specifications and maintenance instructions in the maintenance part of this manual.

© Copyright Spierings Cranes.

All rights reserved.

No part of this publication may be reproduced or published, in any form or in any way, by print, photo print, microfilm or any other means without prior permission from the manufacturer.



## Liability clause

### SECTION 1. OPERATION

- 1.1 The Spierings truck may only be used for the purpose it was manufactured and designed for and only as described in the user manual or in the additions to it.
- 1.2 Any use of the Spierings truck that differs from its design purpose or as described in the use manual or the additions to it, will cause the product warranty and the manufacturer's liability, for any direct or indirect damage, to expire.
- 1.3 Only qualified, skilled personnel are allowed to operate the truck. The driver should have a special driving license for driving heavy vehicles. The driver/operator must be in good physical and mental health, so that he/she is able to carry out the work without restrictions and react with responsibility in all given situations.
- 1.4 The driver/operator/user of the Spierings truck should be informed immediately of any additions/changes to the user manual.

### SECTION 2. SAFETY

- 2.1 For safety reasons the driver/operator/user should carry out all operations as stated in the user manual or in the additions to it.
- 2.2 If more stringent safety demands are locally placed on the truck/crane than specified in the Spierings truck user manual or additions to it, these more stringent requirements must be strictly complied with. If not, all warranty will expire and the manufacturer will not be liable for any damage or costs.
- 2.3 The Spierings truck manufacturer points out explicitly, that the driver/operator/user and local personnel should not enter the cranes/trucks danger zone. If, for any reason or cause, an unexpected situation occurs during operation one should contact the technical department or Spierings Service department first before proceeding.

### SECTION 3. WARRANTY

- 3.1 It is prohibited to carry out modifications or welding to the Spierings truck without prior written permission of the manufacturer of the Spierings truck.
- 3.2 Frequent maintenance and periodic checks should be carried out in accordance with the user manual, or in the additions to it. If maintenance or checks are carried out otherwise, or less frequent, without prior written permission of the manufacturer of the Spierings truck, all warranty will expire and any liability, for direct or indirect damage, is explicitly excluded.



## Explanation of the symbols used



**CAUTION!**



**Wear safety goggles!**



**Wear safety gloves!**



**Wear safety boots!**



**Wear head protection!**



**Use safety belt!**



**Check!**



**Manual action!**



**Automatic action!**



**Wrong!**



**Right!**



**Information!**



## Table of contents

|  |            |
|--|------------|
| PREFACE .....                                  | I          |
| LIABILITY CLAUSE.....                          | II         |
| EXPLANATION OF THE SYMBOLS USED .....          | III        |
| TABLE OF CONTENTS .....                        | IV         |
| <b>1. GENERAL DATA AT4 .....</b>               | <b>1-1</b> |
| <b>2. OPERATION .....</b>                      | <b>2-1</b> |
| 2.1. Get to know the truck .....               | 2-1        |
| 2.2. Truck cab .....                           | 2-5        |
| 2.3. Control panel.....                        | 2-7        |
| 2.4. Driving the Spierings crane .....         | 2-15       |
| 2.4.1. Starting .....                          | 2-15       |
| 2.4.2. Switching off the engine .....          | 2-15       |
| 2.4.3. Driving on the road .....               | 2-16       |
| 2.5. Driving off the road.....                 | 2-17       |
| 2.5.1. Off the road gear (transfer case) ..... | 2-17       |
| 2.5.2. Longitudinal differential lock .....    | 2-17       |
| 2.5.3. Transverse differential lock.....       | 2-17       |
| 2.6. Braking system.....                       | 2-18       |
| 2.6.1. Operating brake.....                    | 2-18       |
| 2.6.2. Parking brake .....                     | 2-18       |
| 2.6.3. Vacuum brake .....                      | 2-18       |
| 2.7. Parking.....                              | 2-18       |
| 2.8. Driving with a trailer.....               | 2-19       |
| 2.9. Towing the crane.....                     | 2-19       |
| 2.9.1. Towing free.....                        | 2-19       |
| 2.9.2. Towing the crane .....                  | 2-19       |
| 2.10. Independent rear axle steering.....      | 2-20       |
| 2.11. Driving with erected tower .....         | 2-21       |
| 2.12. Axle height adjustment.....              | 2-21       |
| <b>3. MAINTENANCE .....</b>                    | <b>3-1</b> |
| 3.1. Safety .....                              | 3-1        |
| 3.1.1. Clothing .....                          | 3-1        |
| 3.1.2. Surroundings .....                      | 3-1        |
| 3.1.3. Diesel engine.....                      | 3-1        |
| 3.1.4. Moving parts .....                      | 3-1        |
| 3.1.5. Oils and coolant.....                   | 3-2        |
| 3.1.6. Environment .....                       | 3-2        |
| 3.1.7. Change oil cooling system.....          | 3-2        |
| 3.1.8. Fire hazard .....                       | 3-2        |
| 3.1.9. Cleaning components.....                | 3-2        |
| 3.2. Maintenance plan truck AT4.....           | 3-1        |
| <b>4. THE DIESEL ENGINE .....</b>              | <b>4-1</b> |
| 4.1. Access to the diesel engine.....          | 4-2        |
| 4.2. Engine oil .....                          | 4-2        |
| 4.2.1. Check engine oil level.....             | 4-2        |



|           |   |            |
|-----------|---|------------|
| 4.2.2.    | Fill up engine oil.....                   | 4-2        |
| 4.2.3.    | Engine oil change.....                    | 4-3        |
| 4.3.      | Engine oil filter.....                    | 4-4        |
| 4.3.1.    | Oil filter replacement.....               | 4-4        |
| 4.4.      | Cooling system.....                       | 4-5        |
| 4.4.1.    | Check coolant level.....                  | 4-5        |
| 4.4.2.    | Fill up coolant.....                      | 4-6        |
| 4.4.3.    | Change coolant.....                       | 4-7        |
| 4.4.4.    | Anti-frost.....                           | 4-7        |
| 4.5.      | Radiator and intercooler.....             | 4-8        |
| 4.6.      | Air inlet system.....                     | 4-9        |
| 4.6.1.    | Cleaning the air filter.....              | 4-9        |
| 4.6.2.    | Air filter cartridge change.....          | 4-10       |
| 4.7.      | Fuel system.....                          | 4-11       |
| 4.7.1.    | Fuel filter change/clean.....             | 4-11       |
| 4.7.2.    | Bleeding the fuel system.....             | 4-12       |
| 4.8.      | Fuel filter/Water separator.....          | 4-13       |
| 4.8.1.    | Drain water separator.....                | 4-13       |
| 4.8.2.    | Clean/replace filter water separator..... | 4-14       |
| 4.9.      | V-belts.....                              | 4-15       |
| 4.9.1.    | Check the V-belts.....                    | 4-15       |
| 4.9.2.    | Adjust the V-belts.....                   | 4-16       |
| 4.9.3.    | V-belt replacement.....                   | 4-16       |
| 4.9.4.    | Gear belt check.....                      | 4-17       |
| 4.9.5.    | Gear belt adjustment.....                 | 4-18       |
| 4.10.     | Exhaust system.....                       | 4-18       |
| 4.11.     | .....                                     | 4-18       |
| 4.12.     | Check and adjust the valve clearance..... | 4-19       |
| <b>5.</b> | <b>DRIVE LINE.....</b>                    | <b>5-1</b> |
| 5.1.      | Clutch and gear box.....                  | 5-2        |
| 5.1.1.    | Specifications gear box.....              | 5-2        |
| 5.1.2.    | Maintenance gear box.....                 | 5-2        |
| 5.1.3.    | .....                                     | 5-2        |
| 5.1.4.    | Check oil level of the gear box.....      | 5-3        |
| 5.1.5.    | Gear box oil change.....                  | 5-3        |
| 5.2.      | Transfer case.....                        | 5-4        |
| 5.2.1.    | Specifications transfer case.....         | 5-4        |
| 5.2.2.    | Maintenance transfer case.....            | 5-4        |
| 5.2.3.    | Check oil level transfer case.....        | 5-4        |
| 5.2.4.    | Transfer case oil change.....             | 5-5        |
| 5.3.      | Axles.....                                | 5-6        |
| 5.3.1.    | Maintenance axles.....                    | 5-6        |
| 5.3.2.    | Check oil level differentials.....        | 5-6        |
| 5.3.3.    | Differential oil change.....              | 5-7        |
| 5.3.4.    | Check oil level hubs.....                 | 5-8        |
| 5.3.5.    | Hubs oil change.....                      | 5-8        |
| 5.4.      | Tires.....                                | 5-9        |
| 5.4.1.    | Maintenance tires.....                    | 5-9        |
| 5.4.2.    | Tire pressure.....                        | 5-9        |
| 5.5.      | Check the brake lining thickness.....     | 5-9        |
| 5.5.1.    | Brakes.....                               | 5-9        |



|            |  |             |
|------------|--|-------------|
| 5.6.       | Clutch.....                                      | 5-10        |
| 5.6.1.     | Checking the clutch.....                         | 5-10        |
| 5.6.2.     | Venting the clutch.....                          | 5-10        |
| 5.6.3.     | Clutch fluid change.....                         | 5-11        |
| <b>6.</b>  | <b>STEERING SYSTEM.....</b>                      | <b>6-1</b>  |
| 6.1.       | Check the steering system.....                   | 6-2         |
| 6.2.       | Align the steering system.....                   | 6-2         |
| <b>7.</b>  | <b>ELECTRICAL SYSTEM.....</b>                    | <b>7-1</b>  |
| 7.1.       | Lighting.....                                    | 7-1         |
| 7.2.       | Dashboard lighting.....                          | 7-1         |
| 7.3.       | Batteries.....                                   | 7-2         |
| 7.3.1.     | Check the batteries.....                         | 7-2         |
| 7.3.2.     | Recharging the batteries.....                    | 7-2         |
| 7.3.3.     | Replacing batteries.....                         | 7-2         |
| <b>8.</b>  | <b>HYDRAULIC SYSTEM.....</b>                     | <b>8-1</b>  |
| 8.1.       | Check oil level hydraulic tank.....              | 8-1         |
| 8.2.       | Hydraulic oil change.....                        | 8-2         |
| 8.3.       | Check the suspension's accumulators.....         | 8-3         |
| <b>9.</b>  | <b>PNEUMATIC SYSTEM.....</b>                     | <b>9-1</b>  |
| 9.1.       | Primary system: brake system.....                | 9-1         |
| 9.2.       | Secondary system: accessories and gearbox.....   | 9-1         |
| 9.3.       | Air dryer.....                                   | 9-2         |
| 9.3.1.     | Air dryer filter change.....                     | 9-2         |
| 9.4.       | Air vessels.....                                 | 9-2         |
| 9.5.       | Air lubricator/water separator.....              | 9-3         |
| 9.5.1.     | Refill air lubricator.....                       | 9-3         |
| 9.5.2.     | Water separator.....                             | 9-3         |
| 9.6.       | Check brake pressure.....                        | 9-4         |
| 9.7.       | Hoses and connections pneumatic system.....      | 9-4         |
| <b>10.</b> | <b>LUBRICATION.....</b>                          | <b>10-1</b> |
| 10.1.      | Central lubrication system (Option).....         | 10-1        |
| 10.1.1.    | Timer central lubrication system.....            | 10-1        |
| 10.1.2.    | Grease reservoir central lubrication system..... | 10-1        |
| 10.1.3.    | Greasing points central lubrication system.....  | 10-2        |
| 10.2.      | Manual lubrication.....                          | 10-3        |
| 10.2.1.    | Outrigger beam cylinders.....                    | 10-3        |
| 10.2.2.    | Driven axles.....                                | 10-3        |
| 10.2.3.    | Cardan shafts.....                               | 10-4        |
| 10.2.4.    | Steering system.....                             | 10-4        |
| <b>11.</b> | <b>VARIOUS.....</b>                              | <b>11-1</b> |
| 11.1.      | Window washer fluid.....                         | 11-1        |
| 11.2.      | Fire extinguisher.....                           | 11-1        |
| <b>12.</b> | <b>TECHNICAL DATA.....</b>                       | <b>12-2</b> |
| <b>13.</b> | <b>ENCLOSURES.....</b>                           | <b>13-1</b> |



**Steering:**

- Axles one, two and four are steered.
- Mechanically coupled steering, where axle four is steered in the opposite direction of axle one and two, realizing a small turning circle.
- Hydraulically powered 1-circuit steering system.
- Hydraulically powered 2-circuit steering system (serialno. 47752 and higher)
- Fitted with an emergency steering pump, so when the main steering pump malfunctions, the truck remains steerable until it is at a standstill.
- Provisions for driving off the road:
- Axle height adjustable
  - high/low gear shift transfer case can be put in low gear for driving off the road
  - longitudinal and transverse differentials can be locked.

**Suspension:**

- Hydro-pneumatic suspension
- The suspension can be blocked (e.g. when driving with erected tower).

**Braking system:**

- Pneumatic brakes.

**4-point outrigger system:**

- Wide support base : 6.55 m x 6.15 m
- Narrow support base : 6.55 m x 5.1 m

**Power supply:**

The superstructure can be supplied with power in two different ways:

- External power-supply 40 kVA during erecting and folding, 40 kVA during operation.
- The truck built-in Leroy Somer 70 kVA generator for power supply to the superstructure when (sufficient) external power is lacking.

**Further data:**

- Maximum speed limited to 85 km/h.
- Minimum speed at 1000 rpm: 1.8 km/h (is 30 m/min) .
- Truck weight including superstructure and counterweight 48,000 kg.
- The axle load is 12,000 kg per axle.





**Identification:**

- Engine number: On top of the engine block.
- Carriage frame number: On the identification plate in the co-driver's leg-room (See *Picture 1-2*) and stamped in the right frame girder in front of the first axle (See *Picture 1-3*).



*Picture 1-2*

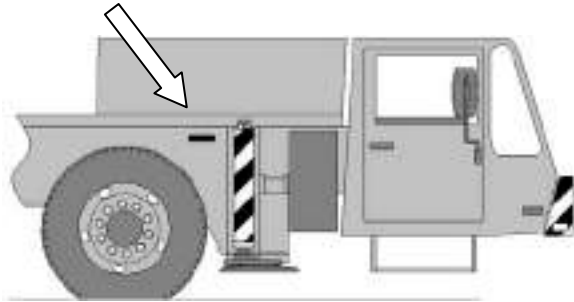

*Picture 1-3*





## 2. Operation

### 2.1. Get to know the truck

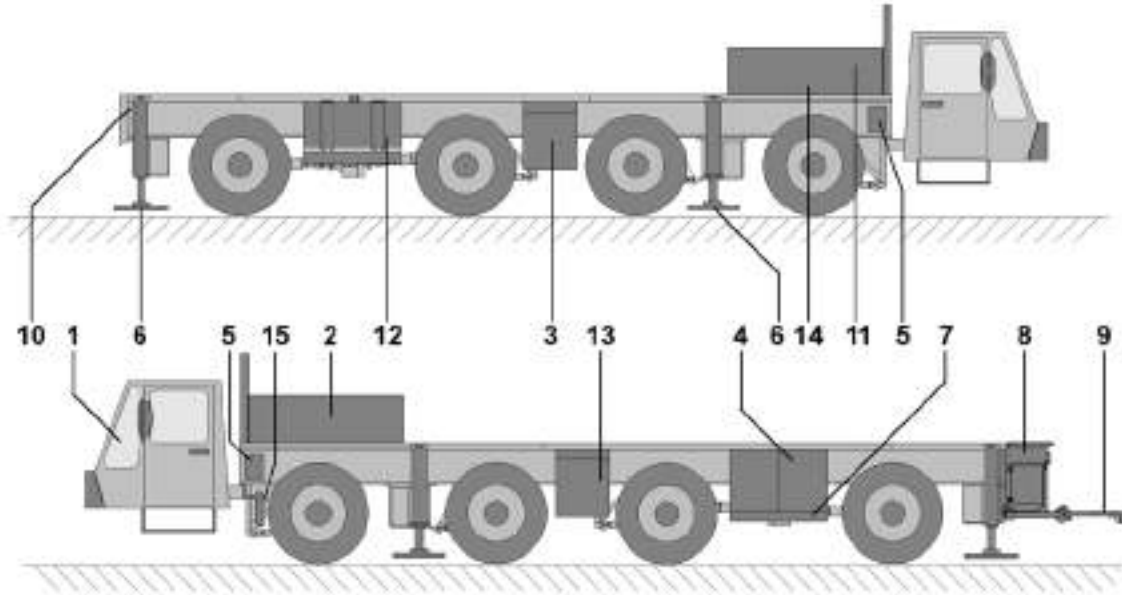

Picture 2-1

#### 1. Truck cab

Besides driving the crane, with the controls in the truck cab you can adjust the carriage axle height and switch the generator (PTO) on and off.

#### 2. Spare tire/Extra sling box/Pallet hook support

On this location you can install one of the following options:

- Spare tire support. The spare tire support is fitted with a winch and is mounted on a swing frame. When you swing the frame out you can lower the spare tire with the winch.
- Extra sling box
- Pallet hook support

#### 3. Storage box/Battery box/Battery switch

On the right hand side between axle 2 and 3 a storage box (2) is located. In this box you will find the batteries (1) of the truck. On the outside of the box the battery switch (3) is located.



Picture 2-2

#### 4. Storage box/Power box

In the storage box on the left side you will find the power-box (2).

With the selector switch on the power-box, the power supply for the crane is selected. Either an external power supply can be connected to this power box, or the built-in generator supplies the power. Power can also be branched off for accessory equipment.



Picture 2-3

#### 5. Outrigger control box

Two control boxes for the outriggers are located just behind the truck cabin. One on the left hand side and one on the right hand side.

#### 6. Outriggers

At both sides of the truck there are 2 extending outrigger beams, and to each beam a hydraulically operated outrigger (See Picture 2-4). These outriggers provide stability during hoisting operation.

- A: Outrigger pad holder
- B: Outrigger beam
- C: Antiskid
- D: Outrigger cylinder
- E: Outrigger pad

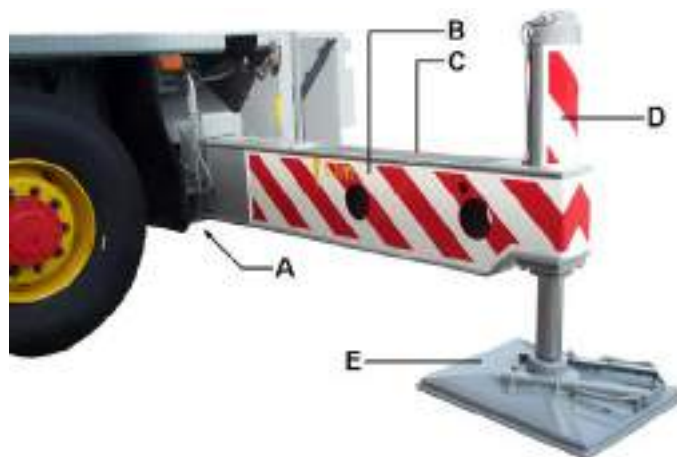

Picture 2-4



### 7. Storage room support plates (optional)

To obtain a solid support base on a weak ground, support plates can be used. Under the storage box on the left hand side (See *Picture 2-3, 1*) as well as under the fuel tank there are 2 support plates each.

### 8. Toolbox at the rear (optional)

For extra storage room a toolbox can be mounted all along the rear of the truck.

### 9. Bumper

The crane has a standard bumper at the rear. When the bumper is folded up, the towing hook can be used (refer "Driving with a trailer").

### 10. Jib turning pipe

At the rear bumper the jib turning pipe is stored. This pipe is used to swing the jib in front of the tower during erecting and back when folding the crane.

### 11. Sling box

A sling box (1) can be mounted on the right-hand engine cowling (2).



*Picture 2-5*

### 12. Fuel tank

The fuel tank capacity is 400 litres.

### 13. Oil tank

The oil tank (2) capacity is 70 litres and is equipped with a gauge-glass (1). (See *Picture 2-6*)



*Picture 2-6*



#### 14. Underneath the engine cowling

Under the engine cowling at the left hand side the filter for the truck's hydraulics (4) can be found. On the right hand side the air dryer (2) and grease pump (1) for automatic lubrication (optional) are located. In the middle you will find the air cleaner (3). (See *Picture 2-7*).

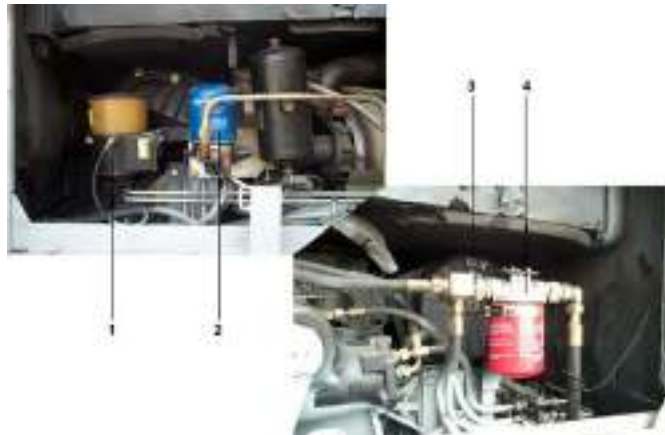

*Picture 2-7*

#### 15. Exhaust valve handle

By operating the exhaust valve handle (1) the engine exhaust gasses can be leaded either through the upper exhaust pipe or the lower exhaust pipe.



*Picture 2-8*



## 2.2. Truck cab

In the truck cab you drive the crane safely and comfortably to its destination. This chapter makes you familiar with the cab.

### Getting in

Use the step under the door. Make use of the steering wheel to hold on to.

### Doors

Turn the handle up to open the door from the inside. The door can only be locked up from the outside. There is an ashtray on the inside of the door. After opening the ashtray, you push the locking device down to remove the ashtray from the holder to empty it.

### Wing mirrors

The wing mirrors may be adjusted by hand. Make sure the mirrors are adjusted before driving off, so that you have satisfactory view. The mirror heating (optional) can be switched on with the switch on the control panel.

### Seats

The cab has room for the driver and a co-driver. Both seats are damped by spring load. The seats can be adjusted. This should only be done when the vehicle stands still.

1. Adjusting knob lumbar support
2. Adjusting knob back position
3. Height adjusting knob
4. Adjusting knob seat position
5. Adjusting lever seat forward/backward
6. Adjusting knob seat height



Picture 2-9

### Fuse box

The fuse box is mounted right-handed at the co-driver's side. You will find the fuses listed in the enclosures.

**Windscreen washer reservoir (2)**

The windscreen washer reservoir is mounted on the left-handed side below the dashboard on the co-driver's side.

(See *Picture 2-10*)



*Picture 2-10*

**Battery charger remote control batteries**

You will find the battery charger (1) for the remote control of the crane on the middle console of the cabin (See *Picture 2-10*).

The remote control of the crane comes with 2 batteries.

While the batteries are charging, an indicator lamp will light up. As soon as they are fully charged, the lamp starts flashing.

**Fire extinguisher**

One fire extinguisher is behind the co-driver's seat.

On the right behind the control box in the crane cab is the second fire extinguisher.

The fire extinguishers must be inspected every year by the authorities.





## 2.3. Control panel

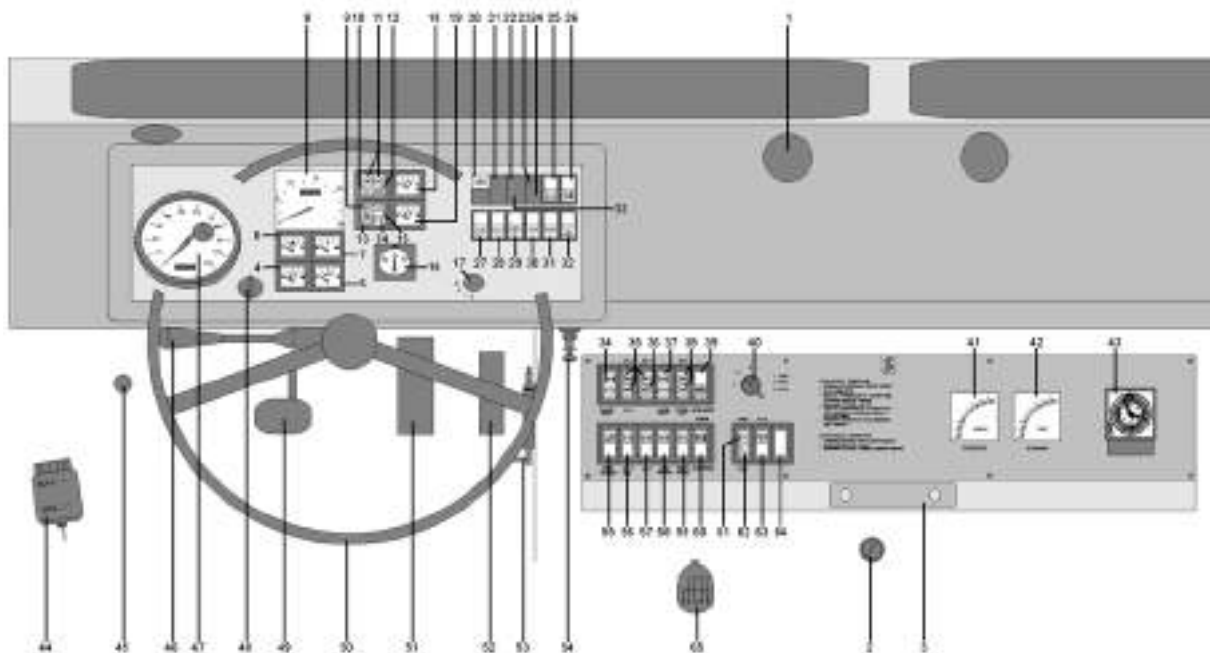

Picture 2-11

- |   |   |  |
|---|---|--|
| 1. Airflow heater   | 29. Switch windscreen washer  | 53. Manual pedal hold                          |
| 2. Heater (this knob can also be located on the left hand side of the tunnel) | 30. Switch cab interior light on the left                                   | 54. Lever parking brake                        |
| 3. Radio  | 31. Switch cab interior light on the right                                  | 55. Switch all axles up / down                 |
| 4. Voltmeter batteries  | 32. Switch alarm light  | 56. Switch axle 1 and 2 up / down              |
| 5. Oil-pressure gauge (diesel engine)   | 33. Blank   | 57. Switch axle 3 up /down                     |
| 6. Fuel gauge   | 34. Switch transverse differential lock axle 2, 3 and 4                     | 58. Switch axle 3 and 4 left up /down          |
| 7. Coolant temperature gauge  | 35. Indicator lamps differential lock axle 2, 3 and 4                       | 59. Switch axle 3 and 4 right up /down         |
| 8. Revolution counter, hours counter  | 36. Indicator lamp max. pressure hydraulic system outriggers / suspension   | 60. Switch / indicator lamp axles blocked      |
| 9. Indicator lamp full head beam  | 37. Switch longitudinal differential lock transfer case and axle 3          | 61. Indicator lamp transfer case high (road)   |
| 10. Indicator lamp charging batteries   | 38. Indicator lamps longitudinal differential lock transfer case and axle 3 | 62. Indicator lamp transfer case low (terrain) |
| 11. Indicator lamps blinker   | 39. Switch / indicator lamp levelling                                       | 63. Switch/indicator lamp PTO engaged          |
| 12. Indicator lamp air pressure   | 40. Switch/transfer case road, terrain, PTO                                 | 64. Blank                                      |
| 13. Indicator lamp air cleaner  | 41. Frequency meter generator   | 65. Gear-lever with splitter                   |
| 14. Indicator lamp flame starting system                                      | 42. Voltmeter generator   |  |
| 15. Indicator lamp oil pressure (diesel engine)                               | 43. Switch clock central lubrication system (optional)                      |  |
| 16. Battery charge gauge  | 44. Reservoir clutch fluid  |  |
| 17. Speed switch fan heater   | 45. Vacuum brake / engine stop  |  |
| 18. Air-pressure gauge circuit 1  | 46. Lever for blinker and full beam   |  |
| 19. Air-pressure gauge circuit 2  | 47. Tachograph, speedometer, mileage, counter, clock                        |  |
| 20. Indicator lamp parking brake  | 48. Ignition lock   |  |
| 21. Mirror heater   | 49. Clutch pedal  |  |
| 22. Working lights  | 50. Steering wheel  |  |
| 23. Indicator lamp steering circuit 1   | 51. Brake pedal   |  |
| 24. Indicator lamp steering circuit 2   | 52. Accelerator pedal   |  |
| 25. Switch rotating beacon  |   |  |
| 26. Switch fog tail light   |   |  |
| 27. Light switch; off, parking light, dipped beam                             |   |  |
| 28. Switch windscreen wiper   |   |  |

**2. Knob heater warm/cold**

Turning this knob, the air of the heater can be set warmer or colder. This knob can also be located on the left hand side of the tunnel.

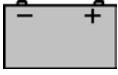
**4. Voltmeter Batteries**

On this meter you can read the battery condition. The meter must be in the middle (approx. 24 Volt)

**5. Oil-pressure gauge diesel engine**

When starting this gauge will read approx. 5 bar. As soon as the oil of the diesel engine is warmed up it will read approx. 3 bar.

**6. Fuel gauge**

This gauge only functions when the ignition is switched on.

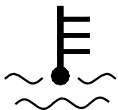
**7. Coolant temperature gauge**

On this gauge you can read the coolant temperature. In the diesel engine safety system an overheating sensor is built-in. As soon as the temperature exceeds 110 °C, it activates the horn. Also the Indicator light "oil pressure" (15) will light up. The engine must be switched off immediately.

**10. Warning lamp charging voltage batteries**

If the charging voltage of the batteries is too low, this indicator lamp will light up.

**12. Warning lamp air-pressure**

If the air-pressure in brake circuit 1 or 2 is below 5.5 bar, this indicator lamp will light up. The crane can and must not be driven. If this lamp is on after starting the engine, leave the engine running at idling speed until the air-pressure is 5.5 bar. The lamp will go out.

**14. Indicator lamp pre-heating diesel engine**

This lamp lights up when pre-heating the diesel engine. The light remains on while holding the ignition key in position 1. Check pre-heating times in chapter "driving with the crane"

**15. Oil-pressure indicator lamp**

Immediately stop the engine when this lamp lights up. The oil pressure of the diesel engine is too low or the coolant temperature is too high.



### 18. Air-pressure gauge circuit 1

It indicates the air-pressure in brake circuit 1. When the pressure is below 5.5 bar, indicator lamp 12 will light up. The crane must not be driven.

### 19. Air-pressure gauge circuit 2

This gauge indicates the air-pressure in brake circuit 2. When the pressure is below 5.5 bar, indicator lamp 12 will light up. The crane must not be driven.

### 20. Indicator lamp parking brake



As long as the parking brake is engaged, this lamp is on (when starting the engine the parking brake remains engaged as long as the air-pressure is below 5.5 bar).

### 21. Mirror heating (optional)



With this switch the mirror heating in the left and right wing mirror is switched on and off.

### 22. Work Lamps (optional)



At the rear of the cab or at the rear truck bumper work lamps can be installed. With this switch the work lamps are switched on and off.

### 23. Indicator lamp steering pressure circuit 1



This lamp is only fitted in case the truck has a two circuit steering system (serialno. 47752 and higher).

This lamp lights up as soon as the oil pressure in steering circuit 1 is too low. Have the malfunction repaired as soon as possible. If this lamp lights together with lamp 24: STOP IMMEDIATELY!

### 24. Indicator lamp steering pressure circuit 2



This lamp is only fitted in case the truck has a two circuit steering system (serialno. 47752 and higher).

This lamp lights up as soon as the oil pressure in steering circuit 2 is too low. Have the malfunction repaired as soon as possible. If this lamp lights together with lamp 23: STOP IMMEDIATELY! When the vehicle stands still, this lamp will light.

**25. Rotating beacon**

With this switch the Rotating beacon can be switched on and off.

**26. Fog tail-light**

With this switch the fog tail-light on the cab can be switched on and off.

**27. Light switch**

By pressing this switch halfway, the parking lights are switched on. By pressing the switch all the way, the dipped beams are switched on.

**28. Windscreen wiper**

By pressing this switch halfway, the windshield wipers wipe at normal speed. By pressing the switch all the way the windshield wipers wipe at high speed. There is no intermittent position.

**29. Windscreen washer**

By pressing this switch the windshield wiper washer is activated.

**30/31. Cab lighting**

The driver can operate the cab lighting by operating the switches on the dashboard. The lighting will also go on when opening the door. We advise you not to switch on the cab lighting when driving in the dark, to prevent annoying reflections in the windscreen.

**34/35. Switch/indicator lamp transverse differential lock.**

Engage the transverse differential locks on axle 2, 3 and 4.

Show if the transverse differential locks on axle 2, 3 and 4 are engaged.

**36. Indicator lamp max. pressure outrigger-/suspension system**

This lamp lights up and a beeper sounds at the rear outriggers as soon as the pressure in the outrigger/suspension system becomes too high. This may happen when the outriggers, the axles or the outrigger beams are fully in or out, or because there is an obstacle in the way when extending the outrigger beams.

During levelling operation, when moving the axles up or down or operating the outriggers this light could also light up. This does not present a problem.



There is a problem in case the light still lights up and the beeper sounds when no buttons are activated. It means that a button of the suspension or outrigger control is still activated. This should be repaired immediately. The diesel engine must be turned off.

#### 37/38. Switch longitudinal differential lock



Engage the longitudinal differential locks on axle 3 and the transfer case.

Show if the longitudinal differential locks on axle 3 and the transfer case are engaged.



#### 39. Switch/indicator lamp levelling

#### 40. Selector switch gear shift high (road) / low (terrain), PTO on/off

With this switch the terrain (*Low*) or the road (*High*) gear can on the transfer case be selected. This is indicated by indicator lamps 61 and 62. With this switch and switch 63 the PTO is engaged.



Transfer case gear shift high (road) / low (terrain) may only be operated when the vehicle stands still!

#### 41. Frequency meter generator

Indicates the frequency in Hertz, supplied by the generator and must be between 52.5 and 53.5 Hz.

#### 42. Voltmeter generator

Indicates the current supplied voltage by the generator. It should be approx. 400V.

#### 46. Steering column switch



Picture 2-12

- A. With this switch the direction indicator is controlled.
- B. Pulling the switch backwards you can give light signals.
- C. Pressing the switch tip towards the steering wheel activates the horn

#### 47. Speedometer / tachograph

The truck is equipped with a VDO or Vederroot tachograph. On this device you can read the driving speed and the number of kilometres driven. The tachograph also contains a clock (1). This clock drives a diagram disc. On this disc the activities of the driver are written by means of scribes. The disc can be replaced by opening slot 2 (See *Picture 2-13*). Never leave a disc in the tachograph for longer than 24 hrs (else it would overwrite itself). In case there is no disc in the tachograph, indicator lamp 3 will light up.

By means of switches 4 and 5 the drivers' activities can be shown. Indicator lamp 3 goes on as soon as the driving speed exceeds 80 km/h. When at a certain speed button 6 is pressed, exceeding this speed will light up the indicator lamp. However, when the ignition is switched off, the indicator lamp will be set to 80 km/h.

The clock may be set to the correct time by operating wheel A.

For more details on how to use the tachograph we refer to the tachograph manual (in the glove compartment).

Note: registration of crane operation by the tachograph is not laid down by law.

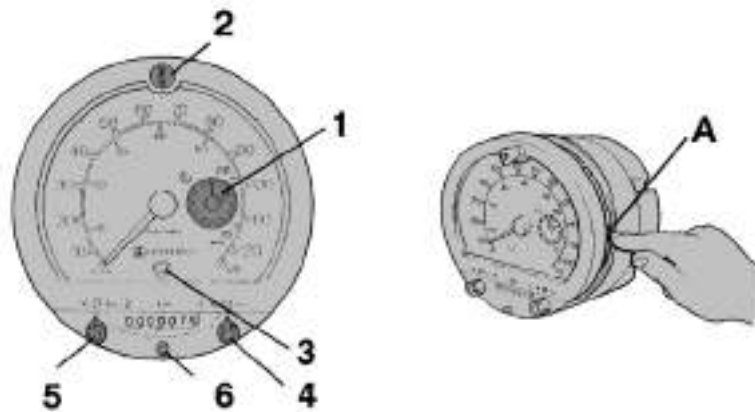

Picture 2-13

#### 48. Ignition lock

By turning the key to the right, three positions are possible, from left to right:

- 1 = ignition on
- 2 = preheat engine (activate flame start system)
- 3 = starting

#### 53. Manual accelerator hold

By turning this lever of the accelerator is being held so that the diesel engine revs up to approx. 1350 rev/min. High rev idling is necessary when using the PTO.. It also can be used when operating the outriggers, because the speeds of the outrigger movements increase.

#### 54. Lever parking brake

Pulling this lever backwards the parking brake is engaged. Pulling out the knob and pushing the lever forwards will release the parking brake. To release the parking brake, the air pressure must be at least 5.5 bar.

**55. Switch for all axles up/down**ALL  
AXLES

With this switch the cylinders of all axles are moved in and out simultaneously (e.g. when supporting the crane on outriggers).

**56. Switch axles 1 and 2 up/down**AXLES  
1-2

With this switch the cylinders of axles one and two can be moved in and out.

**57. Switch axle 3 up/down**AXLE  
3

With this switch the cylinders of axle 3 can be moved in and out.

**58. Switch axle 3 and 4 left-hand side up/down**AXLE  
3-4 L

With this switch the cylinders on the left side of the third and fourth axle can be moved in and out.

**59. Switch axle 3 and 4 right-hand side up/down**AXLE  
3-4 R

With this switch the cylinders on the right side of the third and fourth axle can be moved in and out.

**60. Switch/indicator lamp axle blocked**



### 63. Selector switch PTO



Together with switch 45 the PTO is switched on. While the PTO is switched on indicator lamp 46 lights up. The PTO drives a generator, which supplies power for crane operation.



**While the PTO is switched on, driving the crane is forbidden!**





## 2.4. Driving the Spierings crane

The driver is expected to have a driving license for driving a heavy truck and have sufficient technical knowledge. While driving and manoeuvring the crane, the driver must be aware of the crane's unusual form, measurements and steering characteristics;

- Crane parts sticking out at the front and rear
- Its height of four metres: pay attention to low passage ways and low breaches
- Its width of 2.75 metres: on narrow roads and passage ways it can form an obstruction for other traffic
- Steering conduct: thanks to the opposite steered rear wheels, the crane has a small turning circle. Hereby the rear end may swing out a bit.



**Watch out!**

**The rear end swings out by taking a corner.**

### 2.4.1. Starting

Before starting the engine, the transmission must be put in neutral and the parking brake must be engaged.

Because the engine has a direct diesel injection it needs no pre-heating over 0° C. You can start the engine by simply turning the ignition key to position 3. If the temperature is below freezing point, the engine must be pre-heated. Pre-heating times are:

- 30 seconds at temperatures between 0° C and -10° C
- 90 seconds at temperatures below -10° C

Pre-heating is done by turning the ignition key to position 2. While pre-heating the indicator lamp on the dashboard lights up. The time required for pre-heating the engine is not automatically regulated. When it is for instance freezing -8° C you have to hold the ignition key in position 2 for 30 seconds.

When the engine is running the indicator lamps for oil pressure and battery charging must go out. Only when the oil pressure lamp is out, the engine speed may be increased. When the engine runs too hot or the engine oil pressure is too low, the horn will sound. If the horn keeps sounding, the engine must be switched off immediately. The lamp for steering circuit 2 no. 24 (only on serialnr 47752 or higher) will remain on while the vehicle stands still. It will go out the moment the vehicle starts moving.

In order to drive, the air-pressure in the system must be at least 5.5 bar. Below this pressure the clutch can not be pressed and the parking brake can not be released when operated.

After a cold start you must drive in low gear and at low speed until the coolant temperature reaches 50° C.

### 2.4.2. Switching off the engine

The engine can be switched off by pressing the engine stop button on the floor in the cabin on the left side.

If the engine has run for a longer period of time, we advise you to leave the engine running at idling speed for a few minutes before switching it off, to prevent the coolant and turbo from overheating.



### 2.4.3. Driving on the road

The gearbox has 8 synchronized gears; they are divided in a low range (1st - 4th) and a high range (5th - 8th). To shift between the two ranges, the shift lever must be in neutral position and be pushed to the right through a slight resistance.

Subsequently the high range gears can be engaged. To return to the low range, the gear shift lever must be put in neutral and be pushed to the left.

Refer to the diagram in the picture alongside.

Every gear can be shifted in an intermediate gear; the so-called splitter. Shifting to a lower or higher splitter or v.v. is done by operating the splitter switch. Then press the clutch and release it again.

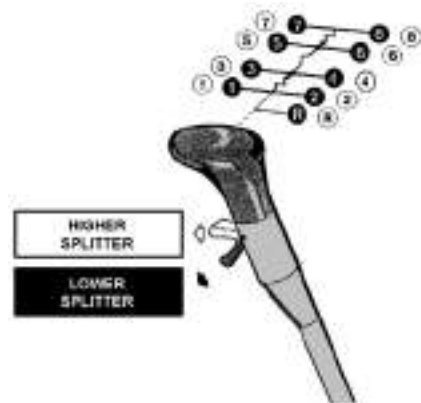

Picture 2-14



#### CAUTION!

While gearing down from high to low range, the driving speed must be below 30 km/h!

Reverse gear is not synchronized, it may only be engaged when the vehicle stands still and the engine runs at idling speed. Also in reverse you can use the high and low splitter.



## 2.5. Driving off the road

### 2.5.1. Off the road gear (transfer case)

When driving off the road or when low speed is required (e.g. driving with erected tower) you can put the transfer case in terrain mode (low speed L).



**CAUTION!**

**The transfer case may only be shifted from high (road) to low (terrain) when the vehicle stands still!**

Indicator lamps on the dashboard (H or L) indicate the position of the transfer case gear (high/low).

### 2.5.2. Longitudinal differential lock

When there is insufficient traction while driving off the road, the longitudinal differentials can be locked with button "longitudinal differential lock".

The indicator lamps next to the button indicate engagement of the longitudinal differential lock.



**CAUTION!**

**The longitudinal differential lock may only be engaged/released when the vehicle stands still.**

**Driving with engaged longitudinal differential lock is only allowed when the vehicle moves in a straight line on loose ground.**

**After releasing the longitudinal differential lock, make sure the indicator lamps are out! If this is not the case, slowly zigzag a little when driving off; this should make the lamps go out.**

### 2.5.3. Transverse differential lock

If after engaging the longitudinal differential lock there is still too little traction, also the differentials in the axles may be locked.

Do this by operating the button "transverse differential lock". The indicator lamps next to the button indicate engagement of the longitudinal differential lock.

Before driving on a paved road, it is required to release the transverse differential lock.



**CAUTION!**

**The transverse differential lock may only be engaged / released provided the vehicle stands still and the longitudinal differential lock is engaged.**

**Driving with engaged transverse differential lock might only when the vehicle moves in a straight line on loose ground.**

**After releasing the transverse differential lock make sure the indicator lamps are out! If this is not the case, slowly zigzag a little when driving off; this should make the lamps go out.**



## 2.6. Braking system

All axles are equipped with drum brakes. The crane is equipped with three braking systems:

- Operating brake
- Parking brake
- Vacuum brake/engine stop

### 2.6.1. Operating brake

The operating brake is operated with the brake pedal and works fully pneumatically. The air pressure is indicated on the dashboard by two air-pressure gauges. If the pressure is below 5.5 bar, it is indicated by the indicator lamp on the dashboard. The crane must not be driven.

### 2.6.2. Parking brake

The parking brake is engaged when the parking brake lever is moved downwards. This bleeds the spring loaded brake boosters and engages the brake. When pulled fully downwards, the lever is locked and the parking brake remains engaged. Pulling out the knob on the lever and pushing the lever upwards will release the parking brake.

If the air pressure for the operating brake is too low, the parking brake is used to slow down the moving vehicle. Move the parking brake lever gradually backwards. Once operated the parking brake can not be released until the air pressure is back to normal. (Also refer to: Towing the crane)

### 2.6.3. Vacuum brake

The vacuum brake works by closing the fuel supply. Also the exhaust is closed by means of a valve. The vacuum brake control is to the left of the clutch pedal on the truck cab floor. While this foot switch is pressed the vacuum brake is active. The vacuum brake is used to slow down through the engine (e.g. when travelling down-hill).



**While the vacuum brake is in use, the engine speed may not exceed 2500 rpm!**

## 2.7. Parking

Put the transmission in low range (1-4) and engage the parking brake. Fully lower the vehicle. Switch off the engine and subsequently the battery switch.

When parking up-hill: transmission in 1st gear, parking brake engaged.

When parking down-hill: transmission in reverse gear, parking brake engaged.

## 2.8. Driving with a trailer

To tow a trailer the crane is equipped with a towing hook with a 7-pins socket for lighting. To link up the trailer, first the bumper must be folded up (See *Picture 2-15*).

1. Remove the safety clips from the 2 pins in the case and pull out the 2 pins.
2. Slide the rear part to the front until the pins can be inserted in the next hole. Then lock them with the safety clips.
3. Remove the safety clip from the pin in the frame and fold up the complete bumper against the vehicle frame.
4. Now lock the bumper with the safety clip.
5. Then pull out the plug from the socket.
6. Link up the trailer and plug the trailer plug in the socket.
7. Check de working of the lights of the trailer.

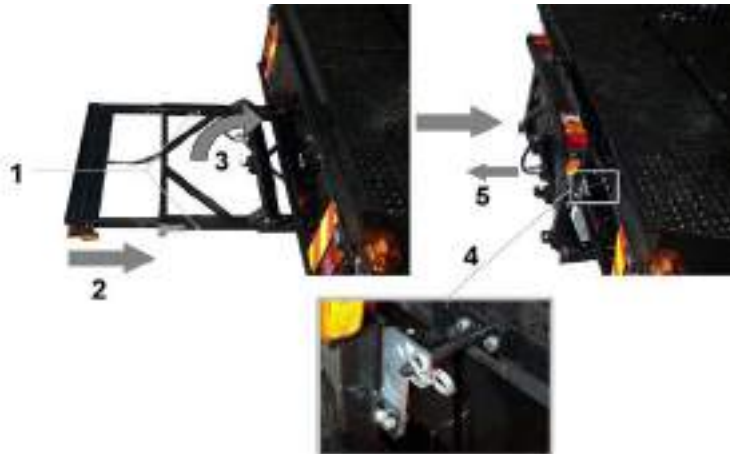

Picture 2-15

## 2.9. Towing the crane

### 2.9.1. Towing free

If the crane has got stuck in the ground, it must be pulled free. To tow, shift the transmission in neutral in the high range (5 to 8).

Forcibly towing or pulling will cause damage to the gearbox. Tow the crane slowly and with sufficient force to firm ground, where it can move in normal travel mode.

### 2.9.2. Towing the crane

When you want to tow the crane without its engine running or in case there is no air pressure, the parking brake must be released manually. To do this you have to unscrew the bolts at the rear of the spring loaded brake boosters of axles 2 and 3 (See: "A", *Picture 2-16*). The spring tension is removed from the brake, so it is released.

Engage the PTO in case of towing the crane over a long distance. By doing this the intermediate gearbox is shifted into its neutral position and the main gearbox is not driven by the axles.

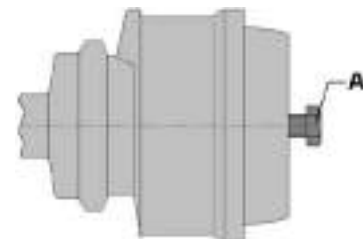

Picture 2-16

Couple the towing vehicle with a coupling-rod to the front of the crane and tow it slowly away from the dangerous situation. In case of doubt always contact the Technical Department of Spierings Kranen.

## 2.10. Independent rear axle steering

With this option, it is possible to steer axle 4 and 5 hydraulic, independent from the other steered axles (axle 1 and 2). By doing so, sideways driving is possible.



To drive with independent rear axle steering the crane should be folded entirely.

- Block the suspension.
- Pull in all suspension cylinders.
- In the truck cab on the driver's side, a switch box is mounted (See Picture 2-17). While driving normally the green lamp (C; rear axle steering locked) and the orange lamp will light (B; Locking position)
- Turn the key in position 1 (E). The steering arm will be unlocked. The green lamp will go out and the red lamp lights up (A; Rear axle steering released). If the wheel are not aligned, the orange lamp does not light up.
- The longitudinal differential lock is automatically engaged.
- Push out all axles. When *independent rear axle steering* is switched on, axle three remains retracted.



Make sure, that the wheels of axle 3 are free from ground (at least 10 cm).

- With the lever (D) you can steer the rear axles.

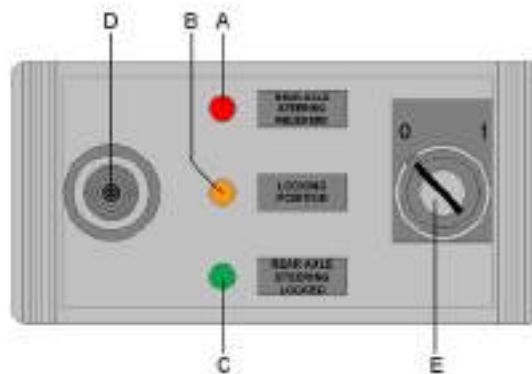

Picture 2-17

Driving with rear axle steering is restricted:

- Only drive in first or second gear, forward or backward. When shifting to the third or fourth gear, a signal sounds. Shifting to the high range (5-8) is not possible.
- The transfer case can be shifted as well to road gear as to terrain gear.
- **Driving with erected tower is not permitted!**
- **Driving with transverse differential locked is not permitted!**

To switch back to normal driving situation, you have to proceed as follows:

- Retract the cylinders until axle 3 (almost) reaches the ground.
- Steer the rear axle until the steering arms are in line (orange lamp will go on).
- Turn the key to position 0. The steering arms of axle 4 will be locked. The red lamp goes out and the green will go on. The longitudinal differential lock will be disengaged. If the red lamp doesn't go out, turn the steering wheel carefully a bit to the left and right until the red lamp goes out.
- The suspension will return in driving position and all the gears can be shifted again.
- After levelling, you can drive normal again.

## 2.11. Driving with erected tower

Refer to crane manual.

## 2.12. Axle height adjustment

The carriage axles are connected to the chassis by means of hydraulic cylinders. Each cylinder is provided with an accumulator, so that the axles can compress.

The suspension system can be controlled from the truck cab (See Picture 2-18). This system enables you to adjust the axle height according to your needs. The suspension can also be blocked; this is relevant when supporting the crane on outriggers and when driving with an erected tower.

The suspension system operation is explained below.

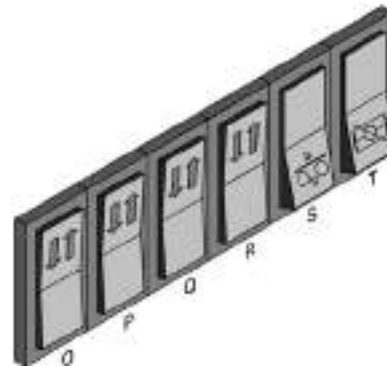

Picture 2-18

- O. switch cylinders of all axles; in / out
- P. switch cylinders axles 1 and 2; in / out
- Q. switch cylinders left-hand side; left wheel axle 3 and 4 in / out
- R. switch cylinders right-hand side; right wheel axle 3 and 4 in / out

In this way, the crane set-up can be levelled on sloping grounds.

As soon as the end position is reached, a buzzer will sound and indicator lamp on the dashboard lights up.

### “Levelling” (S)

During levelling, the axle suspension is automatically adjusted in travelling mode. This is useful when the axle height had become unsettled due to e.g. outrigger operation or lengthy standstill. After using the crane it should always be levelled!

The crane must be levelled on a horizontally level base and the levelling is finished when there is no more movement in the vehicle. Switch the switch for levelling back.

Levelling can only be done when the tower is resting on the truck.



**Switch S “levelling” must be switched off while driving**



Switch T must be on “driving” for levelling operation!

#### “Driving” (T)

In this switch position the suspension is activated. The switch must be in this position while driving on the road.

Before driving off, you have to level first.



#### “Blocking” (T)

In this mode the axles can not compress, enabling a stable travel. In blocking mode the indicator lamp on the switch for blocking/driving is on. In this mode the axles can be moved up or down separately by means of 4 switches. When the system is blocked.



#### “Off-the-road mode”

To shift the crane in off the road mode, you have to proceed as follows:

- Block the axles.
- Move the cylinders of all axles out. The cylinders must not be moved all the way out, otherwise they can not move any further, while driving with the suspension blocked.
- Switch selector switch “T” to driving mode to re-activate the suspension.



### 3. Maintenance



"Under normal operating conditions" means:

- forty-hour week of 5 days
- 15,000 – 20,000 km/year
- Ambient temperature: -15 to 40°C



All oil- and filter specifications are found in Chapter *Technical Data*.

#### 3.1. Safety



Observe all warning and safety rules stated in this document. The safety must be observed at all times.



Never carry out repairs to the truck nor change the settings without explicit approval and necessary education. Bad repair work or wrong settings may cause dangerous situations.

##### 3.1.1. Clothing



Make sure to wear the correct clothing while carrying out maintenance on the truck. . E.g. do not wear loose clothing, loose hanging hair and / or jewellery, which could get caught between moving parts.

##### 3.1.2. Surroundings



The surroundings of the crane to be serviced must be free from oil or other liquids, to prevent hazardous situations.

##### 3.1.3. Diesel engine



Do not run the diesel engine in a closed or non-ventilated room. There is a high risk of suffocation.

##### 3.1.4. Moving parts



Stay at a safe distance from rotating and/or moving parts.



### 3.1.5. Oils and coolant



Different kinds of oil and lubrication, coolant, windscreen washer fluid, battery acid and diesel oil can present a health hazard when touched. Avoid any physical contact with these substances!

### 3.1.6. Environment



In order to be able to meet the present environmental requirements, you are advised to observe the following rules:

- Never pour used engine oil, hydraulic oils, greases and coolant in drains, sewers or on the ground.
- Make sure all used fluids, old batteries, oil filters and other chemical waste, are handed in separately to the proper authorities for recycling or destruction.
- See to proper and regular truck maintenance. A well maintained engine contributes to saving fuel and reduces polluting exhaust fumes.

### 3.1.7. Change oil cooling system



Be careful when changing the oil. Hot oil can cause severe bodily harm.

Never remove the filler cap from the cooling system while the engine is at operating temperature.

### 3.1.8. Fire hazard



To prevent fire hazard the engine and its surroundings must be free from highly inflammable substances.

### 3.1.9. Cleaning components



While cleaning with high-pressure cleaner the following must be observed:

- While cleaning the radiator/intercooler, make sure the cooling fins do not get damaged.
- While cleaning the engine compartment do not aim directly at electrical components such as starter motor, generator, sockets etc.
- Make sure no water penetrates through the breathers on the transmission, transfer case and differentials.



### 3.2. Maintenance plan truck AT4

| Main group        | Maintenance                | Daily maintenance | Weekly maintenance | 2-monthly maintenance | Yearly maintenance (15.000km) | 2-Yearly maintenance | 5- Yearly maintenance |
|-------------------|----------------------------|-------------------|--------------------|-----------------------|-------------------------------|----------------------|-----------------------|
| Diesel engine     | Engine oil                 | Check             |                    |                       | Refresh                       |                      |                       |
|                   | Oil filter                 |                   |                    |                       | Change                        |                      |                       |
|                   | Cooling system             |                   |                    | Check                 |                               |                      |                       |
|                   | Coolant                    |                   | Check              |                       |                               | Refresh              |                       |
|                   | Anti-freeze                |                   |                    |                       | Check                         |                      |                       |
|                   | Radiator/intercooler       |                   |                    |                       | Check                         |                      |                       |
|                   | Air system                 |                   |                    |                       | Check                         |                      |                       |
|                   | Air filter                 |                   | Clean              |                       |                               | Change               |                       |
|                   | Fuel system                |                   |                    |                       | Check                         |                      |                       |
|                   | Fuel filter                |                   |                    |                       |                               | Change               |                       |
|                   | Water separator            |                   | Drain              |                       |                               |                      |                       |
|                   | Filter water separator     |                   |                    |                       |                               | Change               |                       |
|                   | V-belts                    |                   |                    |                       |                               | Check                |                       |
|                   | Exhaust system             |                   |                    |                       | Check                         |                      |                       |
|                   | Valve clearance            |                   |                    |                       |                               | Check                |                       |
| Drive-line system | Gear box                   |                   |                    | Check                 |                               |                      |                       |
|                   | Oil gear box               |                   |                    | Check                 | Refresh                       |                      |                       |
|                   | High/Low transfer case     |                   |                    | Check                 |                               |                      |                       |
|                   | Oil High/Low transfer case |                   |                    | Check                 | Refresh                       |                      |                       |
|                   | Axles                      |                   |                    | Check                 | Check                         |                      |                       |
|                   | Oil differentials          |                   |                    | Check                 | Refresh                       |                      |                       |
|                   | Oil hubs                   |                   |                    | Check                 | Refresh                       |                      |                       |
|                   | tires                      |                   | Check              |                       |                               |                      |                       |
|                   | Tire pressure              |                   |                    |                       | Check                         |                      |                       |
|                   | Brake lining               |                   |                    |                       |                               | Check                |                       |
|                   | Venting the clutch         |                   |                    |                       | Check                         |                      |                       |
|                   | Clutch fluid               |                   |                    |                       |                               |                      | Refresh               |
| Steering system   | System                     |                   |                    | Check                 | Align                         |                      |                       |
| Electrical system | Lighting                   | Check             |                    |                       | Check                         |                      |                       |
|                   | Instrument lighting        | Check             |                    |                       | Check                         |                      |                       |
|                   | Batteries                  |                   |                    | Check                 |                               |                      |                       |
| Hydraulic system  | Hydraulic oil              |                   |                    | Check                 |                               |                      | Analyze               |
|                   | Return oil filters         |                   |                    |                       | Change                        |                      |                       |
|                   | Accumulators               |                   |                    |                       | Check                         |                      |                       |
|                   | Hoses and connections      |                   |                    | Check                 |                               |                      |                       |



| Main group       | Maintenance                  | Daily maintenance | Weekly maintenance | 2-monthly maintenance | Yearly maintenance (15.000km) | 2-Yearly maintenance | 5- Yearly maintenance |
|------------------|------------------------------|-------------------|--------------------|-----------------------|-------------------------------|----------------------|-----------------------|
| Pneumatic system | <i>Air dryer filter</i>      |                   |                    |                       |                               | Change               |                       |
|                  | <i>Air vessels</i>           |                   | Drain              |                       |                               |                      |                       |
|                  | <i>Oil atomizer</i>          |                   |                    | Check                 |                               |                      |                       |
|                  | <i>Water separator</i>       |                   |                    | Drain                 |                               |                      |                       |
|                  | <i>Braking pressure</i>      |                   |                    |                       | Check                         |                      |                       |
|                  | <i>Hoses and connections</i> |                   |                    |                       | Check                         |                      |                       |
| Grease system    | <i>Central grease system</i> |                   | Clean              | Check                 |                               |                      |                       |
|                  | <i>Manual greasing</i>       |                   |                    | Grease                |                               |                      |                       |
| Diverse          | <i>Window washer liquid</i>  |                   | Check              |                       |                               |                      |                       |
|                  | <i>Extinguisher</i>          |                   |                    |                       | Check                         |                      |                       |



## 4. The diesel engine

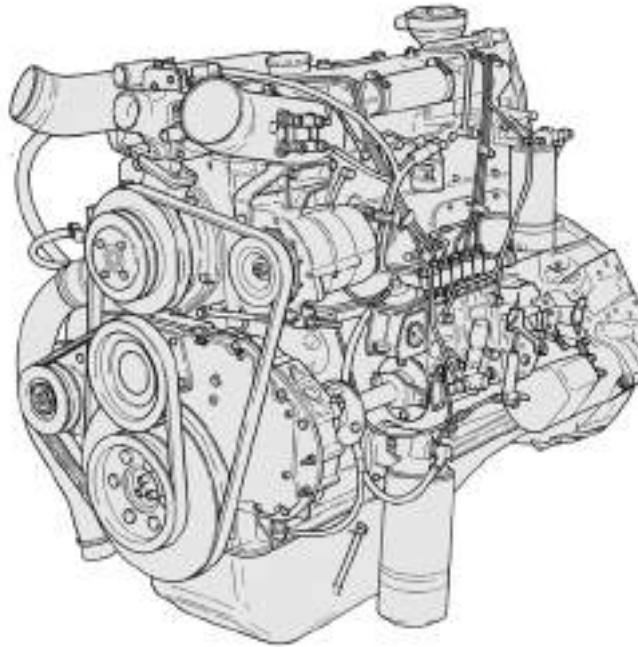

Picture 4-1

As drive source the Spierings AT4 is fitted with a DAF-turbo diesel engine with intercooler.

### Data:

|                         |  |
|-------------------------|--|
| Brand/type:             | DAF WS268L                                     |
| Fuel system:            | Water cooled four stroke with direct injection |
| Inlet system:           | Turbo-intercooler                              |
| Engine capacity:        | 1163 cm <sup>3</sup>                           |
| Maximum performance:    | 268 kW at 2000 rpm                             |
| Maximum torque:         | 1500 Nm at 1250 rpm                            |
| Compression ratio:      | 16,5 : 1                                       |
| Bore x stroke:          | 130 x 146 mm                                   |
| Unloaded idling speed:  | 500 rpm  |
| Unloaded maximum speed: | 2240 rpm                                       |



### Warning!

Only use EN 590 diesel fuel to prevent damage on the fuel system.

## 4.1. Access to the diesel engine

Remove different engine compartment cover plates to get access to the entire engine.

## 4.2. Engine oil

### 4.2.1. Check engine oil level



**Check the engine oil level every day.**

To check the oil level you will find a dipstick (*Picture 4-2*) at the left-hand engine cowling. There is also a filler hole (with red cap) for topping up engine oil (*Picture 4-3*).

- Make sure the crane stands on a horizontally flat base.
- Pull out the dipstick (*Picture 4-2*).
- Clean the dip stick with a non-fluff cloth.
- Put the dipstick back in the holder.
- Subsequently pull it out again and read off the level.
- The oil level must be between the two marks on the dipstick.
- If necessary, top up oil through the filler hole (*Picture 4-3*). Always use oil of the same brand and type (refer to "technical data")

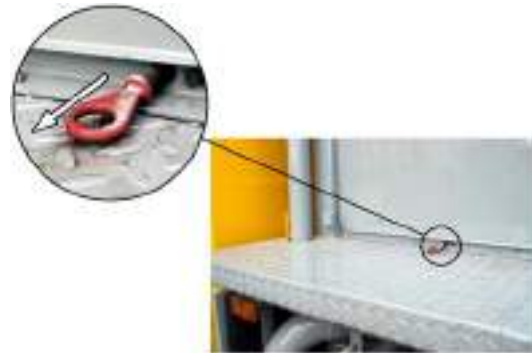

*Picture 4-2*



*Picture 4-3*

### 4.2.2. Fill up engine oil

1. Make sure the crane stands on a horizontally flat base.
2. Unscrew the red filler cap (2) (*Picture 4-3*)
3. Always fill up the engine oil of the same brand and type. (In doubt consult Spierings Cranes)
4. Check the oil level with the dipstick. (*See 4.2.1 Check engine oil level*)



#### 4.2.3. Engine oil change



**Change the engine oil after every 15.000km or every year during the yearly maintenance service at normal working conditions.**

1. Make sure the crane stands on a horizontally flat base.
2. Draining the engine oil should preferably take place when the engine is at operating temperature. The engine must be switched off.
3. Put a trough under the drain plug. (*Picture 4-4, A*)
4. Remove the cap of the fast drainer at the bottom of the crank case and attach the provided drain hose. This hose will open the plug, so the oil can be drained.
5. Remove the drain hose and place the cap on the fast drainer.
6. Fill the engine with approx. 28 liters engine oil. (*See 4.2.2 Fill up engine oil*)

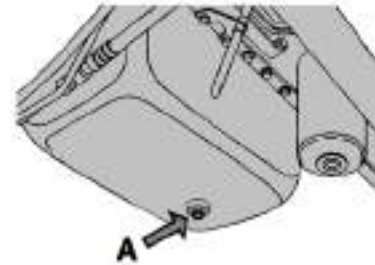

*Picture 4-4*



### 4.3. Engine oil filter

#### 4.3.1. Oil filter replacement



Replace the oil filter after every 15.000km or during the yearly maintenance service at normal working conditions.

Always replace the oil filter for a new one. A used filter may never be cleaned and used again.

1. Place a trough under the filter.
2. Unscrew the filter by means of an oil filter wrench.



Picture 4-5

3. Fill the new filter element with engine oil.
4. Oil the new filter element seal ring with engine oil.



Picture 4-6

4. Mount the filter until the seal makes contact, then tighten the filter with 45 Nm torque.
5. Important: after changing oil and mounting the filter, operate the vacuum brake and let the engine run by means of the starter motor until the oil pressure indicator lamp goes out.
6. Leave the engine running for a short while and make sure the oil filter is properly sealed.
7. Now check the oil level.

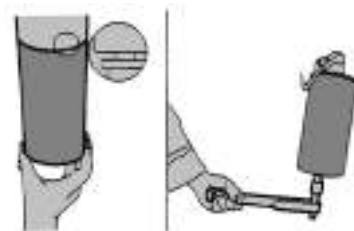

Picture 4-7





#### 4.4. Cooling system



Check every two months for leakages from hoses, tubes, connections and for damage on the radiator, intercooler and fan.

##### 4.4.1. Check coolant level



Check the coolant level every week at normal working conditions.



Never remove the radiator cap when the engine is at working temperature.

In order to check the coolant level and topping it up, the tower must be tilted to approx. 1 metre above the truck cab.

In the middle behind the truck cab is a (blue) filler hole for the coolant. As the coolant reservoir is not mounted horizontally, the truck has to be inclined backwards by extending the front axles and retracting the rear axles. The fluid level must be half way the filler neck of the reservoir. If the coolant level is extremely low, the system must be checked for leaks.

Check the coolant level while the engine is cold. If you have to check when the engine is still hot (just after finishing work) turn the filler cap carefully against the stop to relief the pressure in the cooling system. Then press the filler cap down and turn it until you can remove it.



Picture 4-8



#### 4.4.2. Fill up coolant



**Do not add cold coolant to a hot engine. Is this by a particular circumstance inevitable, add the fluid slowly with a running engine.**



**Coolant is harmful for your health. Protect your eyes and skin.**

1. Put the heater knob on "warm".
2. Carefully remove the filler cap from the coolant tank.
3. Fill up the coolant level to the filler neck.  
(Picture 4-9)
4. Start the engine and slowly fill the coolant system with coolant.
5. Leave the engine running for some minutes.
6. Switch off the engine and check the coolant level.  
(4.4.1 Check coolant level)



Picture 4-9



#### 4.4.3. Change coolant



**Change coolant every two years at normal working conditions.**



**Do not add cold coolant to a hot engine. In this by a particular circumstance inevitable, add the fluid slowly with a running engine.**



**Coolant is harmful for your health. Protect your eyes and skin.**

To prevent damage to the engine block, the engine may not be filled with cold coolant when it is still warm.

Only use coolant or antifreeze which meets the specifications (see "TECHNICAL DATA").

1. Fully open the heater regulator in the truck cabin.
2. Remove the cooling system filler cap.
3. Drain the cooling system (the engine block through drain cock A, the radiator through drain plug B, the oil cooler through drain plug C). Collect the coolant - it must be removed as environmental hazardous waste.
4. Flush the cooling system.
5. Close all draining points.
6. Fill the cooling system with new coolant.
7. Let the engine run for a couple of minutes and check the coolant level. The system is self-bleeding. Make sure the breather line from the thermostat housing to the expansion reservoir is not bent or cut off.
8. Top up coolant if necessary.

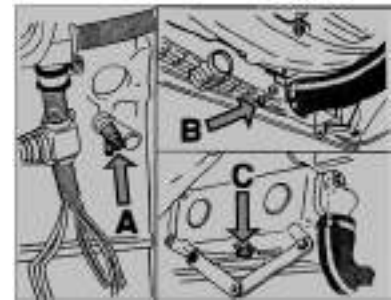

Picture 4-10

#### 4.4.4. Anti-frost



**Check the anti-frost concentration every year before winter season.**

We advise to check the coolants anti-frost concentration before every winter season. Use 40% anti-frost on ethyleneglycol-basis.



#### 4.5. Radiator and intercooler



**Check the radiator and intercooler every year for filthiness.**



**Be careful concerning the electrical system when cleaning with water.  
Never use a high pressure cleaner for cleaning the radiator.**



**Wear safety glasses during cleaning the radiator.**

- Cleaning the radiator with air pressure

Using air pressure for cleaning the radiator is the easiest way. Aim the air pressure nozzle always parallel to the radiator's cooling segments to prevent damage.

- Cleaning the radiator with cold or warm water

Use for preference a cold cleanser. Let this soak for approx. 10 minutes and wash it away with a dense water beam parallel to the radiator's cooling segments to prevent damage.



## 4.6. Air inlet system



Check the air inlet system every two months for leakages and damage.

### 4.6.1. Cleaning the air filter



Clean the air filter every week at normal working conditions. When the air filter cartridge and sealing ring is damaged, renew the cartridge.

1. Remove the air cleaner lid.
2. Remove the air cleaner element from the housing.
3. Clean the inside of the air cleaner filter housing and air cleaner lid.
4. If the air cleaner element or seal is damaged or the is already cleaned once , the air cleaner element must be replaced (see "TECHNICAL DATA").
5. Shake out the air cleaner element.
6. Clean the air cleaner element by means of blowing compressed air from the inside (max. 1.5 bar).
7. Sparingly coat the seal ring inside with Vaseline.
8. Mount the air cleaner in the air cleaner housing. Tightening torque of mounting nut is 20 Nm.
9. Mount the air cleaner lid. Tightening torque of mounting nut is 15 Nm.

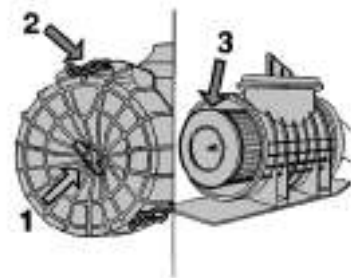

Picture 4-11



Picture 4-12



#### 4.6.2. Air filter cartridge change



**Change the air filter cartridge every year at normal working conditions.**

1. Make sure the engine is not running.
1. Remove the air cleaner lid.
2. Remove the air filter cartridge from the air filter housing.
3. Check for filthiness inside the filter housing and filter cover. Clean if necessary.
4. Install a new filter cartridge after coating the sealing ring with oil. (Use Vaseline)
5. Mount the air cleaner in the air cleaner housing. Tightening torque of mounting nut is 20 Nm.
6. Mount the air cleaner lid. Tightening torque of mounting nut is 15 Nm.

## 4.7. Fuel system



Check the hoses, tubes and connections every two months for leakages and damages.



Open fire is prohibited during work at the fuel system. No smoking!

### 4.7.1. Fuel filter change/clean



Change/clean the fuel filters every 15.000km and during the yearly maintenance service at normal working conditions.

1. Place a trough under the fuel filter.
2. Unscrew the filter.
3. Remove the filter. Collect the leaking fuel.
4. Sparingly oil the sealing of the new filter (see "TECHNICAL DATA"), with engine oil.
5. Place the new filter.
6. Tighten the filter by hand.
7. When necessary bleed the fuel system. (See 4.7.2 *Bleeding the fuel system*)
8. Remove the filter bolt.
9. Remove the strainer (2) from the filter bolt (1).
10. Clean the filter with clean diesel and dry it using compressed air.
11. Reinstall bolt and the strainer.
12. Bleed the fuel system. (See 4.7.2 *Bleeding the fuel system*)
13. Start the engine.
14. As the engine is running, check the fuel system for possible leaks.

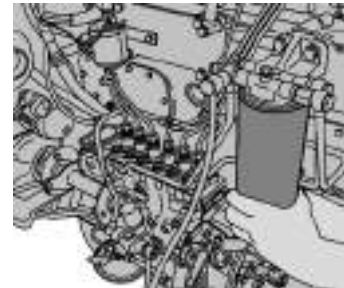

Picture 4-13

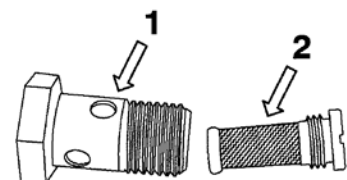
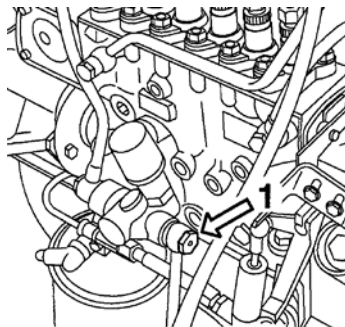

Picture 4-14



#### 4.7.2. Bleeding the fuel system

1. Open the bleed screw (3) on the fuel filter body (left hand side of the diesel engine).
2. Pump fuel out of the bleed screw with the hand pump (4) until no more air bubbles are visible in the fuel hose.
3. Close the bleed screw.

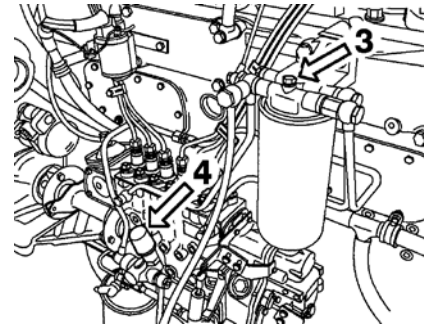

Picture 4-15



## 4.8. Fuel filter/Water separator

### 4.8.1. Drain water separator



**Drain the water separator every week.**

Depending on the serial no. of the crane two different types of water separators can be fitted. Type 1 is a re-useable water separator. Type 2 is a disposable water separator.

#### Draining type 1

The water separator is located between axle 3 and the fuel tank on the right hand side.

1. Put a trough under the water separator.
2. Unscrew bleed plug (1).
3. Unscrew drain plug (2) and drain the water separator until clean fuel comes out.
4. Reinstall the plugs.
5. Bleed the fuel system if necessary.

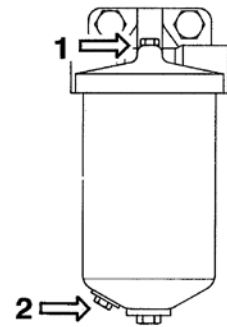

Picture 4-16

#### Draining type 2

1. Put a trough under the water separator.
2. Unscrew bleed plug (1).
3. Unscrew drain plug (2) and drain the water separator until clean fuel comes out.
4. Reinstall the plugs.
5. Bleed the fuel system if necessary.



Picture 4-17



#### 4.8.2. Clean/replace filter water separator



Change the filter inside the water separator every year during the yearly maintenance service at normal working conditions.

##### Clean type 1

6. Put a trough under the water separator.
7. Unscrew bleed plug (1) and the drain plug (2) and drain the water separator.
8. Remove bowl (3) of the water separator by unscrewing the bolt at the bottom of the bowl (4).
9. Remove the fuel hoses from the housing.
5. Remove the housing (5) of the water separator.
6. Clean all parts of the water separator thoroughly.
7. Refit the housing and the hoses.
8. Sparingly oil the new sealing (see "TECHNICAL DATA").
9. Replace the bowl with new seal and fasten it manually.
8. Now bleed the fuel system.

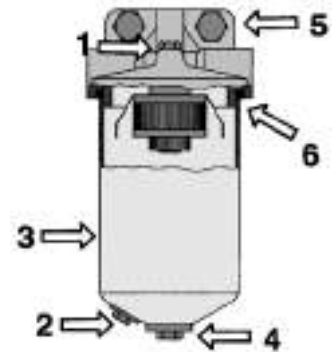

Picture 4-18

##### Replace type 2

1. Put a trough under the water separator.
2. Unscrew bleed plug (1) and the drain plug (2) and drain the water separator. (See Picture 4-6)
3. Remove the filter.
4. Sparingly oil the sealing of the new filter (see "TECHNICAL DATA").
5. Tighten the filter by hand.
6. When necessary bleed the fuel system.
7. Start the engine.
8. As the engine is running, check the fuel system for possible leaks.

## 4.9. V-belts

### 4.9.1. Check the V-belts



**Check the V-belts every 15.000km at normal working conditions and during the yearly maintenance service.**

Check if the belt is worn or damaged. Replace if necessary (see TECHNICAL DATA).

Accurately adjusting the V-belt tension prolongs the belt's service life. The V-belt tension can be checked accurately with a belt tension gauge, DAF number 1240443 for multiple V-belt version or poly-V-belt version.

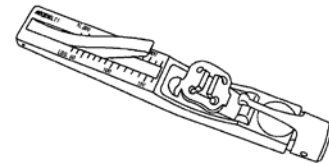

Picture 4-19

1. Set the gauge on zero by pressing the gauge arm (1).

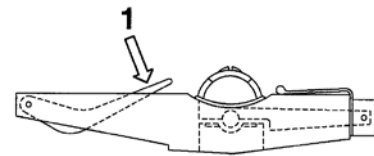

Picture 4-20

2. Place the gauge on the V-belt, in the middle of the maximum distance between two pulleys.
3. Slowly press the V-belt with the belt tension gauge until the gauge produces a click-sound. Then carefully remove the belt tension gauge.

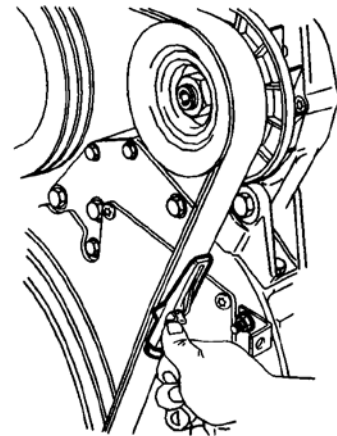

Picture 4-21

4. Read the value indicated by the gauge arm position compared to the scale. Compare this value to the recommended pre-tension (refer to table 1). If necessary correct the v-belt tension.

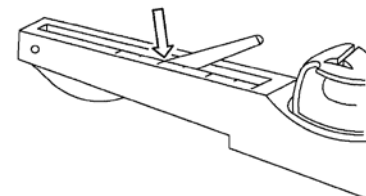

Picture 4-22

| Table 1 - Belt tension "12.5 mm" V-belts in Newton (N)  |                 |            |               |            |
|---|-----------------|------------|---------------|------------|
|   | Multiple V-belt |            | Single V-belt |            |
|   | encased         | open flank | Encased       | open flank |
| New V-belt  |                 |            |               |            |
| Adjustment tension  | 900             | 1200       | 500           | 600        |
| Check tension   | >600            | >800       | >300          | >400       |
| Worn in V-belt  |                 |            |               |            |
| Lowest tension  | 400             | 500        | 200           | 250        |
| Adjustment tension  | 450             | 700        | 250           | 350        |
| (1) Encased V-belts can be recognized by the textile fabric present in the rubber, at the inside as well as at the V-belt flanks. Construction: without teething.   |                 |            |               |            |
| (2) V-belts with open flank can be recognized by the flanks and inside, at which opposite to the belt's top side, there is no textile fabric in the rubber (ground belt flank). Construction: with or without teething. |                 |            |               |            |
| (3) After mounting a new V-belt the pre-tension must be adjusted to the adjustment tension. After the test drive the pre-tension must at least equal the check tension. If necessary, adjust to the check tension.      |                 |            |               |            |
| (4) If the worn-in V-belt is below the "lowest tension" it must be adjusted to the adjustment tension.  |                 |            |               |            |

**4.9.2. Adjust the V-belts**

Adjust the dynamo and water pump drive V-belt tension:

1. Unscrew the spindle lock nut (2), fixing bolt (1) and the dynamo fixing bolts (5) and (7).
2. Unscrew bush lock nut (3) and turn the bush (4) until the correct V-belt tension is achieved.
3. Retighten the fixing bolts and lock nuts.

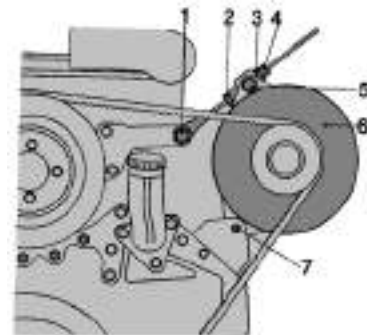

Picture 4-23

**4.9.3. V-belt replacement**

By turning the V-belt tension unit fully back, the belt can be removed and replaced by a new one. Meanwhile check the V-belt pulleys for damage, rust and grease deposit.



#### 4.9.4. Gear belt check



**Check the gear belt during the annual maintenance or every 15.000 operating hours under normal operating conditions.**

The hydraulic steering pump of steering circuit 1 is mounted on the right hand side on the engine. This pump is driven by means of a gear belt.

The transmission of the gear belt will not take place by friction like the V-belt. Therefore the gear belt should not be tensioned.

1. Be sure the engine is shut down.
2. Move the gear belt between the pulleys as shown in Picture 4-24 without force.
3. The deflection should be  $15_0^{+2}$  mm. **(No less than 15mm!)**
4. Adjust the gear belt if necessary.

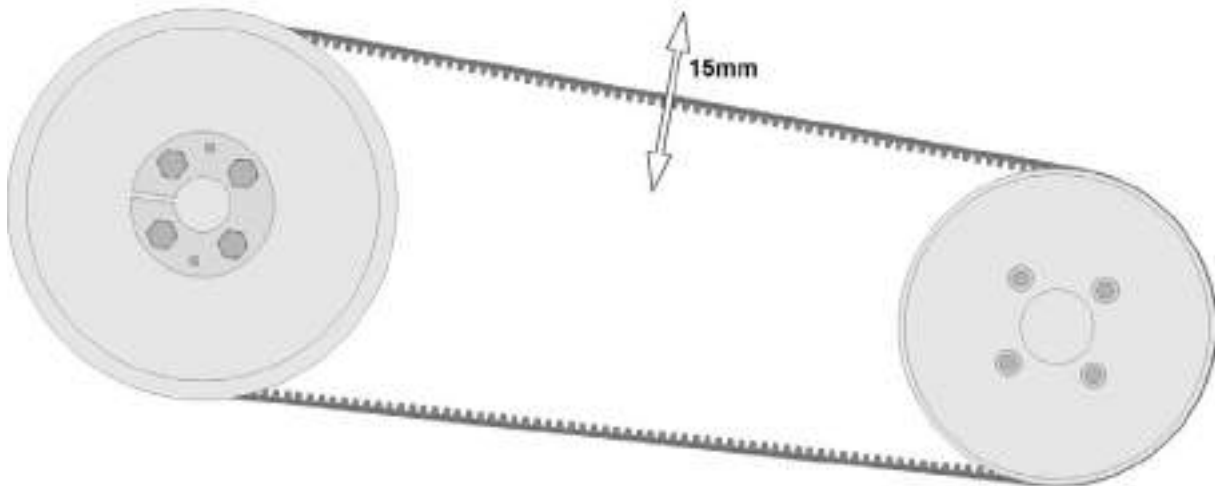

Picture 4-24

#### 4.9.5. Gear belt adjustment

**Warning!**

Never tighten gear belts during adjustment. The pump can be damaged this way.

1. Loosen the locknut on the spindle (4, Picture 4-25).
2. Re-adjust the hydraulic pump (2) with the pulley (3) using the adjustment nut on the spindle.
3. Adjust the gear belt as described in 4.9.4 Gear belt check.
4. Tighten the locknut on the spindle.



Picture 4-25

#### 4.10. Exhaust system



Check the exhaust system every two months for leakages of the damper, exhaust-pipe and flanges.

**Caution!**

After running the engine, the exhaust system is hot.

#### 4.11.



#### 4.12. Check and adjust the valve clearance



**Check, and adjust when necessary, the valve clearance during the yearly maintenance service.**



**Cleaning the engine before dismantle it prevents that filth will penetrate.**

1. Clean the valve housing covers rim and remove the valve housing covers and gasket.
2. Make sure the fuel pump is in off position. If necessary lock the fuel pump in off position.
3. Turn the crankshaft by means of the fixing bolt on the dynamo pulley to the right, seen from the distributor side, (this is similar to the engine direction of rotation), until the 1st cylinder valves start to tumble. Now the first and 6th cylinder piston is in B.D.C. position of the compression stroke.  
With "tumble" we mean the moment at which the inlet valve starts to open and the outlet valve finishes closing.
4. Check and adjust the valve clearance of the 6<sup>th</sup> cylinder. The valve clearance of inlet as well as outlet must be 0.45 mm. Adjust the correct valve clearance by unscrewing the locknut and turn the adjustment bolt in the correct direction.
5. By repeatedly turning the crankshaft 1/3 of a turn, the valves can be adjusted in the injection sequence (1-5-3-6-2-4). See table 2.
6. Clean the sealing surface on the valve housing cover, and reinstall the valve housing cover with a new gasket (see TECHNICAL DATA). Tighten the fixing bolts on the valve housing cover with 25 Nm.

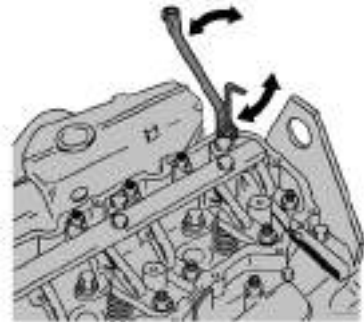

Picture 4-26

| Table 2 - Injection sequence |                               |
|------------------------------|-------------------------------|
| Tumbling valves of cylinder: | Adjusting valves of cylinder: |
| 1                            | 6                             |
| 5                            | 2                             |
| 3                            | 4                             |
| 6                            | 1                             |
| 2                            | 5                             |
| 4                            | 3                             |







## 5. Drive line

Picture 5-1 shows the drive line of the AT4 truck.

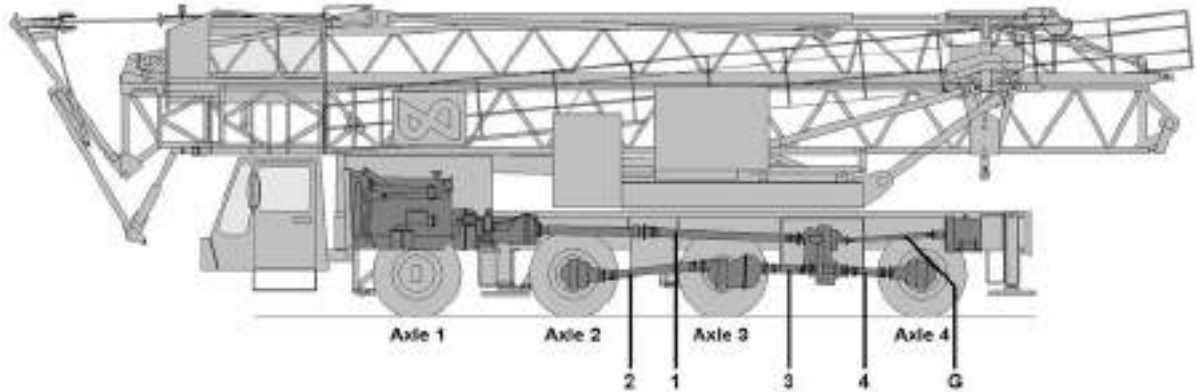

Picture 5-1

1. Universal joints cardan shaft gearbox-transfer case (2x)
2. Universal joints cardan shaft axle nr. 3 - axle nr. 2 (2x)
3. Universal joints cardan shaft transfer case – axle nr. 3 (2x)
4. Universal joints cardan shaft transfer case – axle nr. 4 (2x)



## 5.1. Clutch and gear box

### 5.1.1. Specifications gear box

The ZF 16S-151 gearbox, installed in the AT4, has 16 gears forward and two gears reverse.

The gearbox shifts automatically (by means of air pressure) between the low and high range.

The dry disc clutch (F&S) between gearbox and engine is single. The operation is hydraulic and air powered. On the gearbox, a hydraulic pump is installed, which is shift on continuously, and is intended for the suspension and outrigger system.

To prevent gearing down to the lower range at too high speed, an extra valve is mounted on the gearbox.



Picture 5-2

### 5.1.2. Maintenance gear box



**Check the gearbox every two months for external leakages and filth on the breather.**



**Make sure no water penetrates through the breather by using a high pressure cleaner. This could cause serious damage to the gear box.**

### 5.1.3.

#### 5.1.4. Check oil level of the gear box



Check the oil level of the gear box every two months at normal working conditions.



To prevent measuring faults: Do not check the oil level when the gear box is hot. The oil temperature must be below 40°C (104F).

1. Make sure the truck stands on a horizontally flat base.
2. Unscrew the plug from the filler hole (2). (Picture 5-3)
3. The oil level should be at the rim of the filler hole. If not, fill it up through the filler hole. (2)
4. Reinstall the plug.



Picture 5-3

#### 5.1.5. Gear box oil change



Change the gear box oil every year during the yearly maintenance service at normal working conditions.



**Caution!**

The gear box and oil are hot after driving the truck for a while.

1. Make sure the truck stands on a horizontally flat base.
2. Put a trough under the drain plugs.
3. Unscrew the magnetic drain plugs (1 and 4). (Picture 5-3)
4. Clean the magnetic drain plugs and renew the seals.
5. Reinstall the drain plugs after draining the oil.
6. Fill the gear box with approx. 7.3 litre oil through the filler hole till the oil level reaches the rim.

## 5.2. Transfer case

### 5.2.1. Specifications transfer case

The transfer case is a STEYR type VG2001/396. This transfer case divides the power at the inlet (1, by means of a cardan shaft connected to the driven shaft of the gear box) over two outlets. (Picture 5-4)

One outlet (2) drives axle 2 and axle 3.

Outlet (3) drives axle 4. (See Picture 5-1)

Outlet (4) drives the generator.

The transfer case has two transmission ratios:

High: 1 : 0,89

Low: 1 : 1,536

A hydraulic pump is driven by outlet axle (A). This emergency pump is used when the engine fails and the vehicle is still moving.

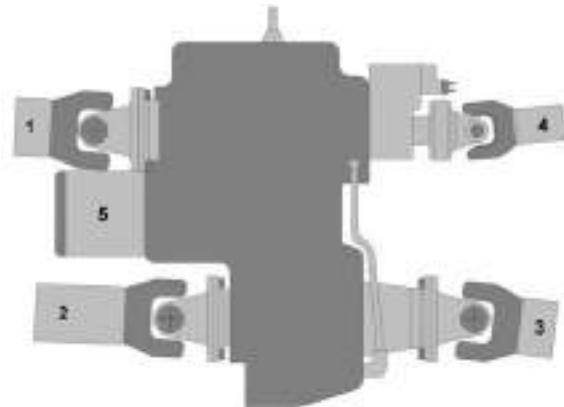

Picture 5-4

### 5.2.2. Maintenance transfer case



Check the transfer case every two months for leakages and filth on the breather.



Make sure no water penetrates through the breather by using a high pressure cleaner. This could cause serious damage to the transfer case.

### 5.2.3. Check oil level transfer case



Check the oil level of the transfer case every two months at normal working conditions.



To prevent measuring faults: Do not check the oil level when the transfer case is hot. The oil temperature must be below 40°C (104F).

Drive shaft (A) is the inlet shaft and drive shaft (B) drives axles 2 and 3. (Picture 5-5)

1. Make sure the truck stands on a horizontally flat base.
2. Unscrew the plug from the filler hole (2). (Picture 5-5)
3. The oil level should be at the rim of the filler hole. If not, fill it up through the filler hole (2).
4. Reinstall the plug.

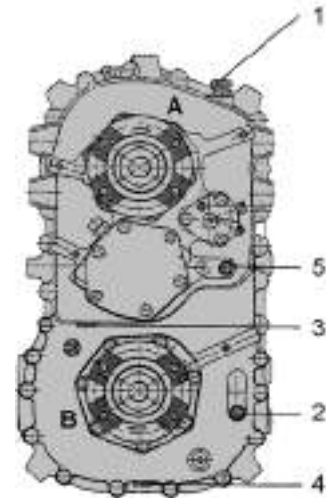

Picture 5-5

#### 5.2.4. Transfer case oil change



**Change the oil of the transfer case every year during the yearly maintenance service at normal working conditions.**



**Caution!**

**The transfer case and oil are hot after driving the truck for a while.**

1. Make sure the truck stands on a horizontally flat base.
2. Put a trough under the drain plugs.
3. Unscrew the drain plugs (3 and 4). (Picture 5-5)
4. Clean the drain plugs and renew the seals.
5. Reinstall the plugs after draining the oil.
6. Remove the plugs from the filler holes (2 and 5).
7. Fill the transfer case with approx. 6.5 liter oil through the filler holes till the oil level reaches their rims.
8. Reinstall the plugs of the filler holes with renewed seals.



### 5.3. Axles

All axles are Ginaf axles.

| Axle number | Steered | Driven | Differential | reduction |
|-------------|---------|--------|--------------|-----------|
| Axle 1      | Yes     | No     | -            | -         |
| Axle 2      | Yes     | Yes    | Single       | 6,57      |
| Axle 3      | No      | Yes    | Lead-through | 6,57      |
| Axle 4      | Yes     | Yes    | Single       | 6,57      |

#### 5.3.1. Maintenance axles



Check the hubs and differentials of axle 2, 3 and 4 every two months for leakages and filth on the breathers.



Make sure no water penetrates through the breathers by using a high pressure cleaner. This could cause serious damage to the hubs and differentials.

#### 5.3.2. Check oil level differentials



Check the oil level of the differentials every two months at normal working conditions.



To prevent measuring faults: Do not check the oil level when the differentials are hot. The oil temperature must be below 40°C (104F).

1. Make sure the truck stands on a horizontally flat base.
2. Unscrew plug (B) from the filler hole of the differential. (Picture 5-6)
3. The oil level should be at the rim of the filler hole. If not, fill it up through the filler hole (B).
4. Reinstall the plug.

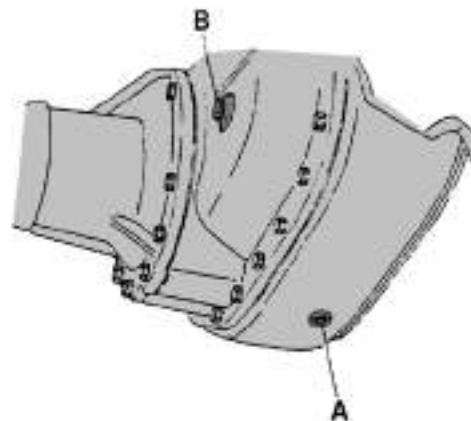

Picture 5-6



### 5.3.3. Differential oil change



Change the oil in the differentials every year during the yearly maintenance service at normal working conditions.



**Caution!**

The differentials and oil are hot after driving the truck for a while.

1. Make sure the truck stands on a horizontally flat base.
2. Drain the oil through drain hole (A) concerning axle 2 and 4. (Picture 5-7)
3. Reinstall the drain plug.
4. Fill the differentials with approx. 11 litre oil till the oil level reaches the rim. (B) Check the level after a while and refill if necessary.

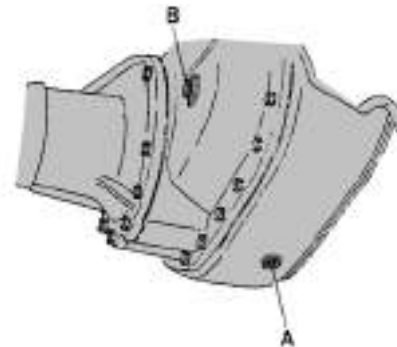

Picture 5-7

Two oil drains (A) are used concerning axle 3. (Picture 5-8)

1. Reinstall the drain plugs.
2. Fill the differentials with approx. 13 liter oil till the oil level reaches the rim. (B)
3. Check the level after a while and refill if necessary.

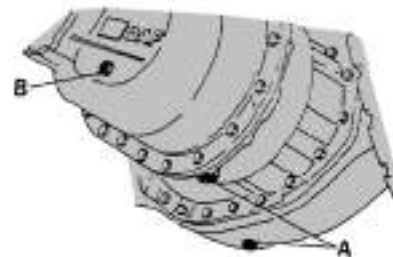

Picture 5-8

#### 5.3.4. Check oil level hubs



Check the oil level of the hubs every two months at normal working conditions.



To prevent measuring faults: Do not check the oil level when the hubs are hot. The oil temperature must be below 40°C (104F).

1. Make sure the truck stands on a horizontally flat base.
2. Make sure that drain plug (A) is at his highest point. (Picture 5-9)
3. Remove plug (B) from the filler hole.
4. The oil level should be at the rim of the filler hole. If not, fill it up through the filler hole (B).
5. Reinstall the plug.

Repeat this for all eight hubs.

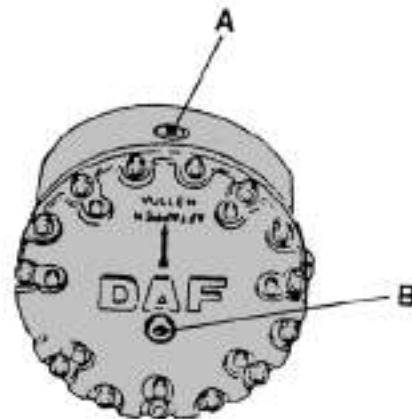

Picture 5-9

#### 5.3.5. Hubs oil change



Change the oil of the hubs every year during the yearly maintenance service at normal working conditions.



**Caution!**

The hubs and oil are hot after driving the truck for a while.

1. Make sure the truck stands on a horizontally flat base.
2. Make sure that drain plug (A) is at his lowest point. (See Picture 5-9)
3. Put a trough under the drain plug.
4. Unscrew the drain plug (A).
5. Clean the plug and renew the seal.
6. Reinstall the drain plug after draining the oil and turn the hub until the drain plug (A) is at his highest point.
7. Unscrew plug (B).
8. Refill the hubs till the rim through filler hole (B).



## 5.4. Tires

### 5.4.1. Maintenance tires



**Check the tires rims every week at normal working conditions.**

To ensure safety, all tires and rims must be checked regularly for wear and damages. This has to be done on the outside as well on the inside of the wheels. To get better access, turn the wheels entirely to the left or right using the steering wheel.

### 5.4.2. Tire pressure



**Check the tire pressure every two months at normal working conditions.**

Check all tires for a tire pressure of **10 bar**.  
Correct this if necessary.

## 5.5. Check the brake lining thickness



**Check the brake lining thickness every year during the yearly maintenance service at normal working conditions.**

To check the brake lining thickness, remove the synthetic sealing caps at the rear of the brake drums (*see Picture 5-10*).  
Now you can check if the brake lining is still sufficient.  
If in doubt make use of the wear ridge to check.

- Proceed by first supporting the crane on outriggers and removing the wheels.
- Subsequently unscrew the 3 fixing bolts on the brake drums.
- Then the brake drum is pushed from the hub by means of screwing 3 bolts M12x50 in the respective bores.
- Now check in view of the wear ridge how far the brake lining is worn and replace it if necessary. The brake lining must be replaced at a thickness of approx. 8 mm



*Picture 5-10*

### 5.5.1. Brakes

We advise to test the brakes every year on a brake tester.

## 5.6. Clutch



Check the clutch every year during the yearly maintenance service at normal working conditions.

### 5.6.1. Checking the clutch

1. Press the clutch pedal a few times completely in.
2. It is necessary to vent the clutch when the clutch feels "spongy".
3. Feels the clutch "hard", driving gives no problems.

### 5.6.2. Venting the clutch



#### Caution!

During venting the clutch fluid level must stay above the minimum level.

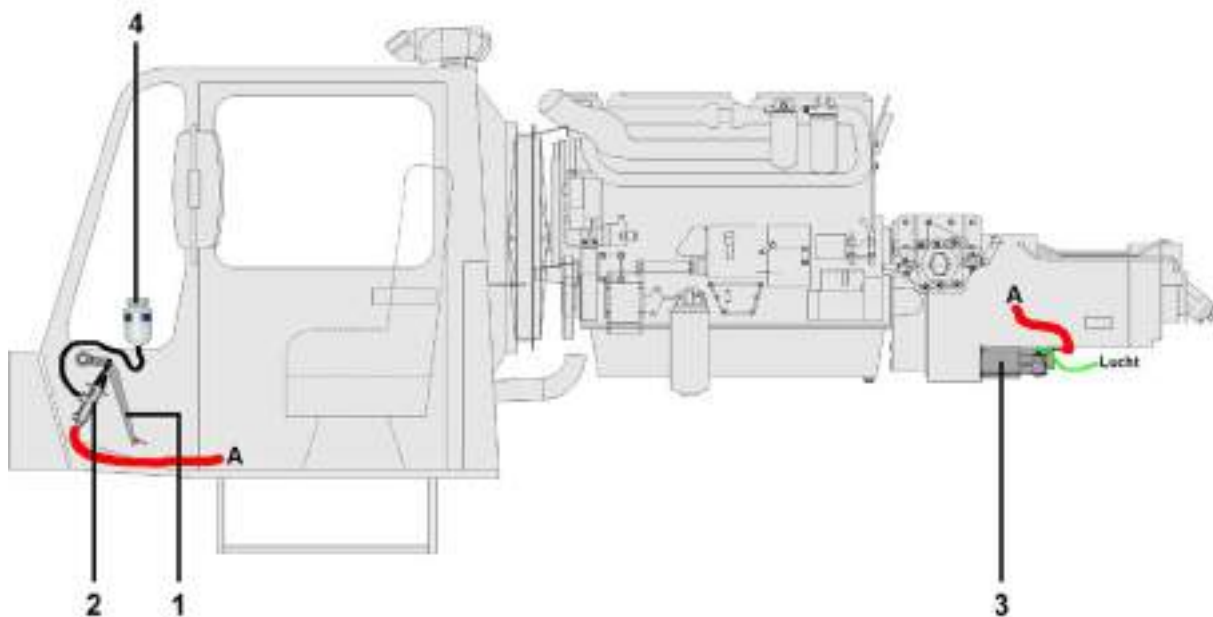

Picture 5-11



1. Be sure the engine is turned off.
2. Vent the 10 litre accessories tank.
3. Person 1: Press the clutch pedal for 2/3. (Picture 5-11, 1 and 2)
4. Person 2: Vent the clutch by opening the vent nipple. (The vent nipple is located on the cylinder beneath the clutch housing.) (See Picture 5-11, 3 and Picture 5-12, B)



Picture 5-12

5. When the clutch feels "hard" close the vent nipple.
6. Fill up the clutch fluid tank with clutch fluid.

### 5.6.3. Clutch fluid change



**Change the clutch fluid every two years at normal working conditions.**

1. Be sure the engine is turned off.
2. Vent the 10 litre accessories tank.
3. Place a drainage hose onto the vent nipple (B, Picture 5-12) of the cylinder (3). (Beneath the clutch housing)
4. Open the nipple by turning it half a stroke.
5. Pump all the fluid out of the system by means of the clutch pedal (1 en 2) until no fluid comes out of the vent nipple.
6. Fill up the reservoir (4) with new clutch fluid and pump it in the system by means of the clutch pedal.
7. Keep pumping and filling until clean clutch fluid appears at the vent nipple.
8. Close the vent nipple and remove the drainage hose.
9. Fill up the reservoir if necessary. The fluid level in the reservoir should always be above the minimum mark.





## 6. Steering system

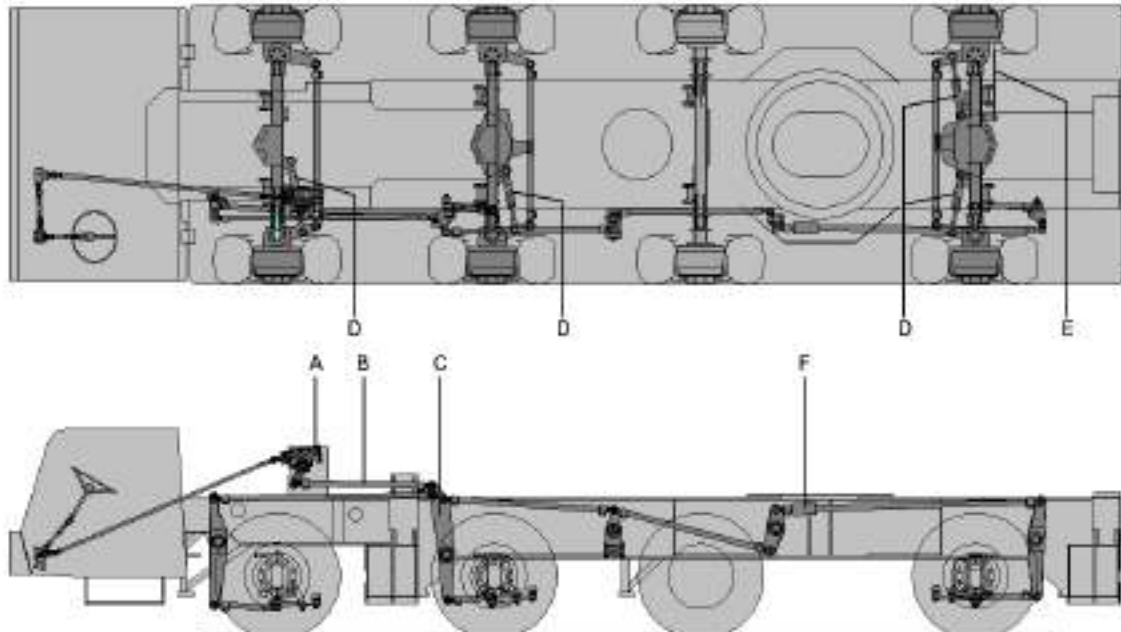

Picture 6-1

- A) Steering housing
- B) Steering rods
- C) Steering arms
- D) Hydraulic auxiliary steering cylinders
- E) Emergency cylinder

Picture 6-1 shows how the steering system is built.

The turning motion of the steering wheel is mechanically converted to the motion of the steering rods. These in turn operate the steering arms, whereas the 4<sup>th</sup> axle steers opposite compared to the first and second axle. This provides a small turning circle.



## 6.1. Check the steering system



**Check the play of the steering arms, ball joints, steering housing (bolts) and steering rods every two months.**

1. The crane must be fully folded.
2. Person 1: Wiggle the steering wheel to the left and right.
3. Person 2: Check the play of the steering arms, ball joints, steering housing (bolts) and steering rods.
4. Repair if necessary.

## 6.2. Align the steering system



**To prevent excessive tire wear, align the steering system every year during the maintenance service.**

All play in the steering system must be checked before aligning it.

Please contact Spierings Kranen for instructions.



## 7. Electrical system

The on-board voltage is 24 volt. It is supplied by two 12 volt/165Ah batteries, series connected. They are charges by a 24V alternator with a maximum charging current of 35A.

With the battery switch next to the battery box, the truck's electrical circuit can be cut off. It must be done in case of welding jobs and when the crane is parked for a longer period of time.

On the co-drivers side in the dashboard, a print with fuses and relays is situated. Even so are some electrical components situated under the middle console.

In the enclosures you will find all electrical diagrams.

### 7.1. Lighting



**Check the lighting of the truck every day before driving off and during the yearly maintenance service.**

Replace a lamp as soon as possible when the lamp is dead or when the lamp shines too bright. Do this to guarantee optimal safety.

### 7.2. Dashboard lighting



**Check the dashboard lighting every day before driving off and during the yearly maintenance service.**

Check the dashboard lighting for broken indicator lamps. Replace as soon as possible to prevent serious damage of the vehicle.



### 7.3. Batteries

#### 7.3.1. Check the batteries



**Check the batteries of the truck every two months.**



**Caution!**

**Battery acid is harmful for human and environment. Be very careful with it!**

The batteries must be checked on the following points:

- Is the fluid level still acceptable (Fill it up with distilled water when necessary)
- Is there no cable wear
- Are the battery clamps still attached on the right way
- Are the batteries still attached on the right way
- Do the batteries need to be recharged

#### 7.3.2. Recharging the batteries

You need a charging device and a charging cable for recharging the batteries.

If you use a quick-charger, all battery cables must be disconnected in order to prevent damage to electronic components.

1. Be sure the engine is not running. (Remove the ignition key from the ignition slot)
2. Connect a cable on the batteries and the charger.
3. Switch on the charger device.
4. First switch off the charger device after charging the batteries.
5. Remove the cable.
6. Start the engine and leave it for several minutes.

#### 7.3.3. Replacing batteries

We advise to replace the batteries when the engine will start difficulty. (The batteries must be fully recharged.) Use new batteries with the same brand and dimensions.

1. Be sure the engine is not running. (Remove the ignition key from the ignition slot)
2. First remove the battery clamp (2) at the “-” poles. Next those on the “+” poles. (*Picture 7-1*)
3. Remove the battery-holder (3).
4. Remove the old batteries (1) and place the new ones.
5. Reinstall the battery-holder.
6. First connect the battery clamp at the “+” poles. Next those on the “-” poles. (Be sure to tighten them well)
7. Use Vaseline to grease the poles.
8. Start the engine and leave it for several minutes.



*Picture 7-1*



## 8. Hydraulic system

### 8.1. Check oil level hydraulic tank



Check the oil level of the hydraulic tank every two months at normal working conditions.



To prevent measuring faults: Do not check the oil level when the oil is hot. The oil temperature must be below 40°C (104F).

1. Make sure the truck stands on a horizontally flat base.
2. Check the gauge (2) of the oil tank (1). The oil level must be at approx. 80% of the gauge. (Picture 8-1)
3. If necessary fill up the tank with hydraulic oil through the filler hole (3).
4. Always use hydraulic oil of the same brand and type. (Consult Spierings Kranen in case of doubt).



Picture 8-1

Below the engine cowling near the steering housing is another tank situated. (Picture 8-2) This tank is hydraulically supplied with oil by the hydraulic pumps and is therefore always full. The surplus on oil will be returned to the main tank. The oil level of this tank does not need to be checked.

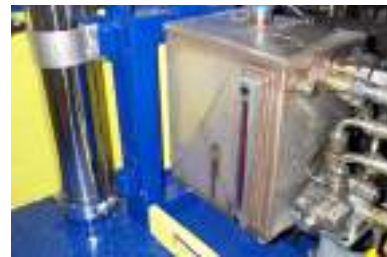

Picture 8-2

## 8.2. Hydraulic oil change



Change the hydraulic oil every 5 years after analysis.

First analyze an oil sample before changing the oil. When oil change is necessary all hydraulic cylinders (including the suspension cylinders) must be retracted.

1. Unscrew the filling cap (2) from the oil tank (*Picture 8-3*)
2. Put a trough under the drain plug (1).



*Picture 8-3*

3. Remove the drain plug and drain the oil out of the tank.
4. Reinstall the drain plug with a renewed seal.
5. Fill the hydraulic tank with 95 liter oil through the filler hole.
6. Start the engine and approx. 20 liters of oil will be pumped to the oil tank near the steering housing. The gauge on the main hydraulic tank indicates an oil level of  $\pm 80\%$ .

The hydraulic system return oil filter is situated behind the left hand engine cowling. If you want to replace it, you first have to unscrew bleed nipple (1, *Picture 8-3*). Then unscrew the filter (2, *Picture 8-4*) by means of a filter wrench. Before mounting the new filter element you first have to coat the sealing ring with oil. After replacing the return oil filter you have to check the oil level and top it up if necessary.



*Picture 8-4*



### 8.3. Check the suspension's accumulators



**Check the suspension's accumulators every year during the yearly maintenance service at normal working conditions.**

The suspension system of the AT4 has eight accumulators. All are mounted on the hydraulic suspension cylinders of every axle. You need a special tool of HYDAC to check the accumulators. The pressure must be 110 bar.





## 9. Pneumatic system

The pneumatic system consists of a primary system and a secondary system.

- The primary system is for the brakes of the truck
- The secondary system is for the accessories

A compressor mounted on the engine delivers the air pressure.

Further is the system secured by a four-circuit safety valve. If one circuit has a leakage, this valve sees to it that the remaining circuits keep air pressure.

### 9.1. Primary system: brake system

Relay valves are the foundation of the braking system. Control lines from the brake pedal valve and parking brake valve operates the relay valves. When operated, the valves activate the brake boosters by means of the feeder lines.

The braking system consists of three air vessels:

- Vessel 1 (60 liter)  
Activates the (working)brake boosters of axle 1 and 2.
- Vessel 2 (60 liter)  
Activates the (working)brake boosters of axle 3 and 4.
- Vessel 3 (40 liter)  
Activates the parking brake boosters of axle 2 and 3.

The parking brake activates by venting the boosters.

### 9.2. Secondary system: accessories and gearbox

A secondary system is present to control all pneumatic components of the drive system.

This system needs its own 10 liter vessel. To extend life of the valves a pressure reducer with water separator and air lubricator is mounted.

The pressure reducer is adjusted for 7 bar.

The secondary system consists of two air vessels:

- Vessel 4 (10 liter)  
Controls all secondary components (accessories).
- Vessel 5 (5 liter)  
An emergency vessel for the clutch. When the air pressure in the secondary system fails, changing gears is still possible a few times.

Components activated by the secondary system:

- Gear box: - Controlling various functions gear box
- Engine brake: - Shut off the exhaust valve  
- Switch of fuel pump
- Transfer case: - Switch off high/low gearing  
- Switch off longitudinal differential lock
- Axles: - Switch off transverse differential lock axle 2, 3 and 4



### 9.3. Air dryer

To extend life of all components and guarantee their operation, the pneumatic system consists of an air dryer.

#### 9.3.1. Air dryer filter change



**Change the air dryer filter every two years at normal working conditions.**

Important for proper operation and long service life of the pneumatic system is a dry and clean compressed air condition. Contaminations in the pneumatic system must be prevented. If water joins the air, it can cause corrosion to various components, resulting in bad operation and a short service life of the components.

Therefore, the pneumatic system is fitted with an air dryer. It is situated at the left hand side underneath engine cowling. The air dryer filter must be replaced every 2 years (*For type; refer to "Technical data"*). It can be removed by means of a filter wrench. After the seal ring is oiled, the new filter can be installed.



Picture 9-1

### 9.4. Air vessels



**Check the air vessels every week for the presence of condensate water.**

Check the air vessels for condensate water by pushing the drainage valve mounted underneath the vessels. When there is regularly condensate water found, change the air dryer filter. (See 9.3.1 Air dryer filter change)



Picture 9-2



## 9.5. Air lubricator/water separator



**Check the level of the air lubricator and drain the water separator every two months at normal working conditions.**

The air lubricator/ water separator is shown in *Picture 9-3* and consist of the following components:

1. Pressure reducing valve
2. Water separator
3. Water separator drain valve
4. Control screw air lubricator
5. air lubricator



*Picture 9-3*

### 9.5.1. Refill air lubricator

1. Make sure the diesel engine is not running.
2. Unscrew the bowl (5) and top up with oil.
3. Reinstall the bowl with oil.
4. Eventually adjust the amount of lubrication by means of the control crew (4).

### 9.5.2. Water separator

If necessary, drain water from the water separator using the valve (3). Do this by turning the valve into its neutral position and press.

- When there is air pressure, the valve is closed
- When there is no air pressure, the separator drains automatically.

Turning the knob clockwise, the valve will be closed.

The air pressure in the secondary system can be adjusted by means of knob (1).



## 9.6. Check brake pressure



**Check the brake pressures of all axles every year during the yearly maintenance service.**

An inspected pressure gauge must be attached to the brake boosters in order to measure its pressure. Turn on the engine and activate the brake pedal valve.

- Pressure brake boosters of axle 1 and 2: 7,8-9,8 bar
- Pressure brake boosters of axle 3 and 4: 7,0 bar

If necessary adjust the pressures by means of the pressure reducing valves mounted in the feeder lines.

Also check the pressure of the system. Attach a pressure gauge to one of the 60 liter vessels. The system pressure must be 9,8 bar. If not, adjust the pressure by means of the overpressure valve mounted on the air dryer.

## 9.7. Hoses and connections pneumatic system



**Check all components of the pneumatic system every two months for leakages and damages.**

All hoses, connections, pneumatic valve blocks, filters, cylinders and air vessels for leakages and damages. If necessary replace the component as soon as possible to prevent serious damage.





## 10. Lubrication

### 10.1. Central lubrication system (Option)



**Check all the lubrication points of the central lubrication system every 2 months. Also check the grease reservoir for sufficient grease.**

Joints, hinges and bearings must be lubricated regularly. A central (automatic) lubrication system is therefore used. Nevertheless all grease points must be checked for sufficient grease. If not, damage is the result.

#### 10.1.1. Timer central lubrication system

The central lubrication system is controlled by a timer on which the grease time in relation to the operating time can be set. (Picture 10-1)

The timer must be set in such a way that 24 hours of operation are followed by 15 minutes greasing. To do this one clock slide must be extended.

When the timer is set to "Auto" or "A" the timer starts functioning. If extra greasing is needed, the grease pump can be operated by setting the timer to "I". The timer must be set to "Auto" after 15 minutes.

The central lubrication system timer is in the centre console at the co-driver's side.



Picture 10-1

#### 10.1.2. Grease reservoir central lubrication system

Check the grease level in the reservoir.

It must be above MIN (1). If not, fill it, e.g. by means of a grease gun, through the respective grease nipple (2). Use grease according to the specification in "TECHNICAL DATA".

The grease pump (with reservoir) for the automatic lubricating system is located underneath the engine cowling at the right hand side (See Picture 10-2).

In order to check and fill it, the side cover plate of the engine cowling of the truck must be removed.



Picture 10-2



10.1.3. Greasing points central lubrication system

1. Pin joints (1) suspension cylinders above and below. (Picture 10-3)
2. Hubs (2) above and below (Except axle 3)

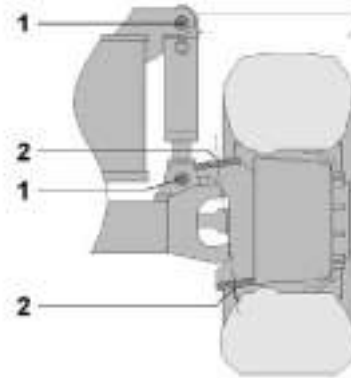

Picture 10-3

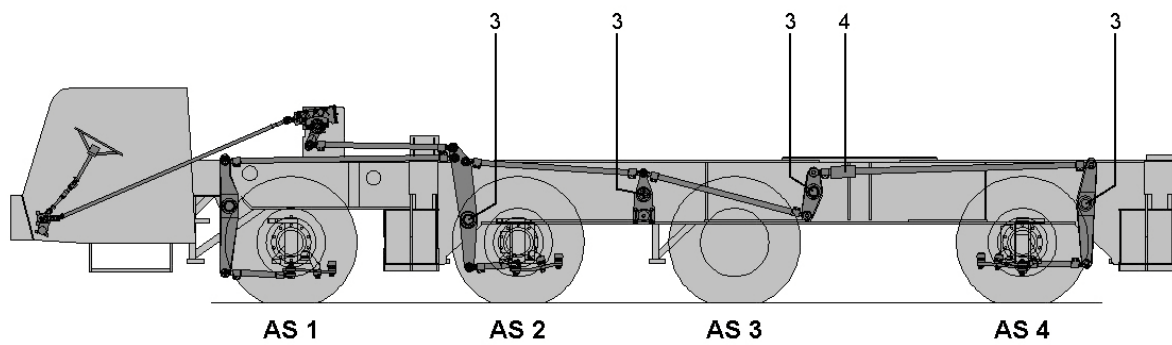

Picture 10-4

3. Pin joints steering arms (3)
4. Spring-loaded rod (4)



## 10.2. Manual lubrication



The grease interval for all manual greasing points is 2 monthly.



When not chosen for the central lubrication option, the lubrication points mentioned in chapter 10.1.3. should be manual lubricated too.

Use a grease gun with EP2 grease for manual lubrication.

### 10.2.1. Outrigger beam cylinders

In *Picture 10-5* is shown the position of the grease nipple of the cylinder inside the outrigger beam. (A)

Extend the outriggers to reach the grease nipples through the holes. (1 nipple per outrigger beam)



*Picture 10-5*

### 10.2.2. Driven axles

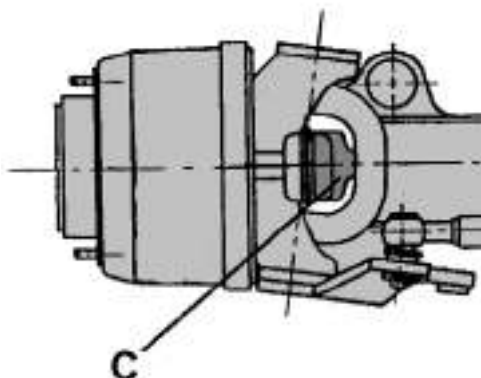

*Picture 10-6*

Grease all universal joints manually shown in *Picture 10-6, C*.



### 10.2.3. Cardan shafts

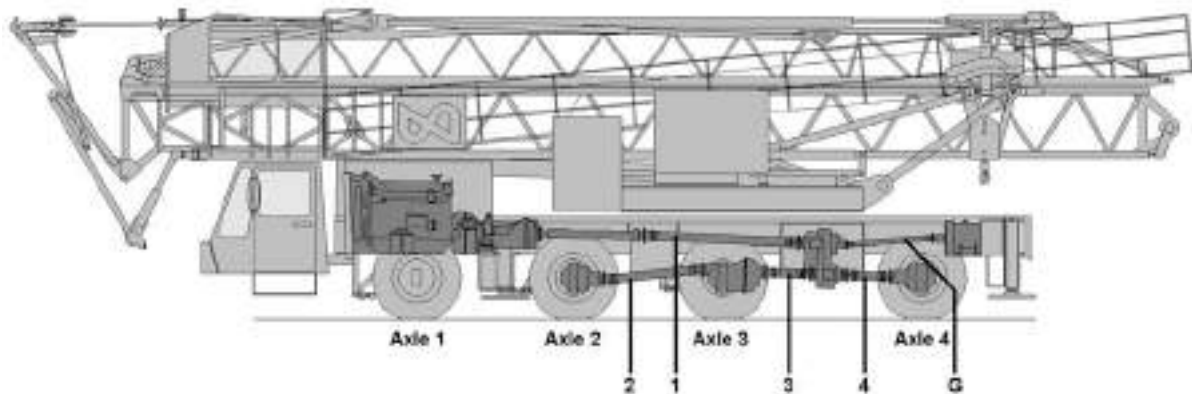

Picture 10-7

1. Cardan universal joints gear box
2. Cardan universal joints axle 2
3. Cardan universal joints axle 3
4. Cardan universal joints axle 4
- G. Cardan universal joints PTO

### 10.2.4. Steering system

The various steering rods ball joints are maintenance-free. Only the steering rod spline bushings must be manually lubricated. (Picture 10-8, 6)

Also check the play of all joints and connections of the steering system.

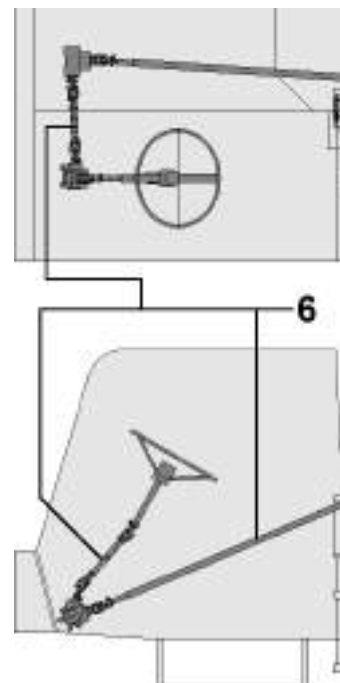

Picture 10-8



## 11. Various

### 11.1. Window washer fluid



Check the window washer fluid level every week.

### 11.2. Fire extinguisher



The fire extinguisher must be inspected every year by an acknowledged instance.



## 12. Technical data

| <b>Diesel Engine</b>                                  |  | <b>Spierings no.</b> |
|---|--|----------------------|
| Engine oil  | SAE 15W40 ACEA E4-98   |                      |
| Oil filter (2x)                                       | DAF No. MAN W92  | SERV02100010         |
| V-belt water pump, fan and dynamo drive               | DAF No. 1283100  | AADI09500950         |
| V-belt  | DAF No. 0067669  | AADI09500275         |
| Belt hydraulic pump two circuit steering system       | Sinchronflex 10/1080   | AADI09325108         |
| Belt-tension gauge single belt                        | Krikit I (DAF No. 1240442)   |                      |
| Belt-tension gauge twin-belt                          | Krikit II (DAF No. 1240443)  |                      |
| Coolant   | SAE-J-1034 or ASTM D 3306<br>(e.g. COOLELF PLUS 37°C)                                  |                      |
| Air cleaner   | MAN C30703   | SERV03100040         |
| Water separator (type disposable)                     | DAF No. 1319159  | SERV01150010         |
| Fuel filter   | DAF No. 1318696, MAN W962/4  | SERV01100010         |
| Starter motor   | Bosch EV 4.0 kW  |                      |
| Injector tools  | DAF no. 1329309 en 0694928   |                      |
| <b>Gearbox</b>  |  |                      |
| Oil gearbox (at delivery)                             | SAE 15W40 ACEA E4-98   |                      |
| Oil gearbox (maintenance at Spierings)                | ELF: TRANSELF SYNTHESE FE 75W90  |                      |
| Clutch fluid  | Rrake fluid DOT 4<br>ELF: Frelub 650   |                      |
| <b>Transfer case</b>                                  |  |                      |
| Oil transfer case (at delivery)                       | SAE 80W90 API GL5/MIL-L-2105D  |                      |
| Oil transfer case (maintenance at Spierings)          | ELF: TRANSELF SYNTHESE FE 75W90  |                      |
| Seal ring drain plug                                  | D.ring-A22x27-Cu DIN 07603   |                      |
| <b>Axles/brakes/tyres</b>                             |  |                      |
| Oil hubs and differentials (at delivery)              | SAE 80W90 API GL5/MIL-L-2105D  |                      |
| Oil hubs and differentials (maintenance at Spierings) | ELF: TRANSELF SYNTHESE FE 75W90  |                      |
| Brake lining  | Ferodo 3652 F  | AAAS03000010R        |
| Tyres   | 445/65 R22.5   |                      |
| Tyre pressure   | 10 bar   |                      |
| Rim   | 22,5" x 14"  |                      |
| <b>Hydraulics</b>                                     |  |                      |
| Oil hydraulics  | ATF Dexron-IID, -IIE, -III of Mercon-M<br>(±100 liter)<br>(e.g. ELF Elfmatic G3 22051) |                      |
| Oil filter  | Hydac 0160   | SERV04200010         |
| <b>Miscellaneous</b>                                  |  |                      |
| Grease (general)                                      | EP2 (e.g. AVIA Mystiek JT-6)   | OLSM01500030         |
| Grease autom. Lubricating system                      | EP2 (e.g. AVIA Mystiek JT-6)   |                      |
| Oil air lubricator                                    | ISO/UNI FD22 (e.g. Berulit 75)   |                      |



## 13. Enclosures

1. General
2. Hydraulics
3. Pneumatics
4. Fuses
5. Proximity switches
6. Electrical diagram
7. Electrical box and terminal boxes