

1 Schedule drawing

1.1 Schedule drawing, WOLFF 5020.6clear

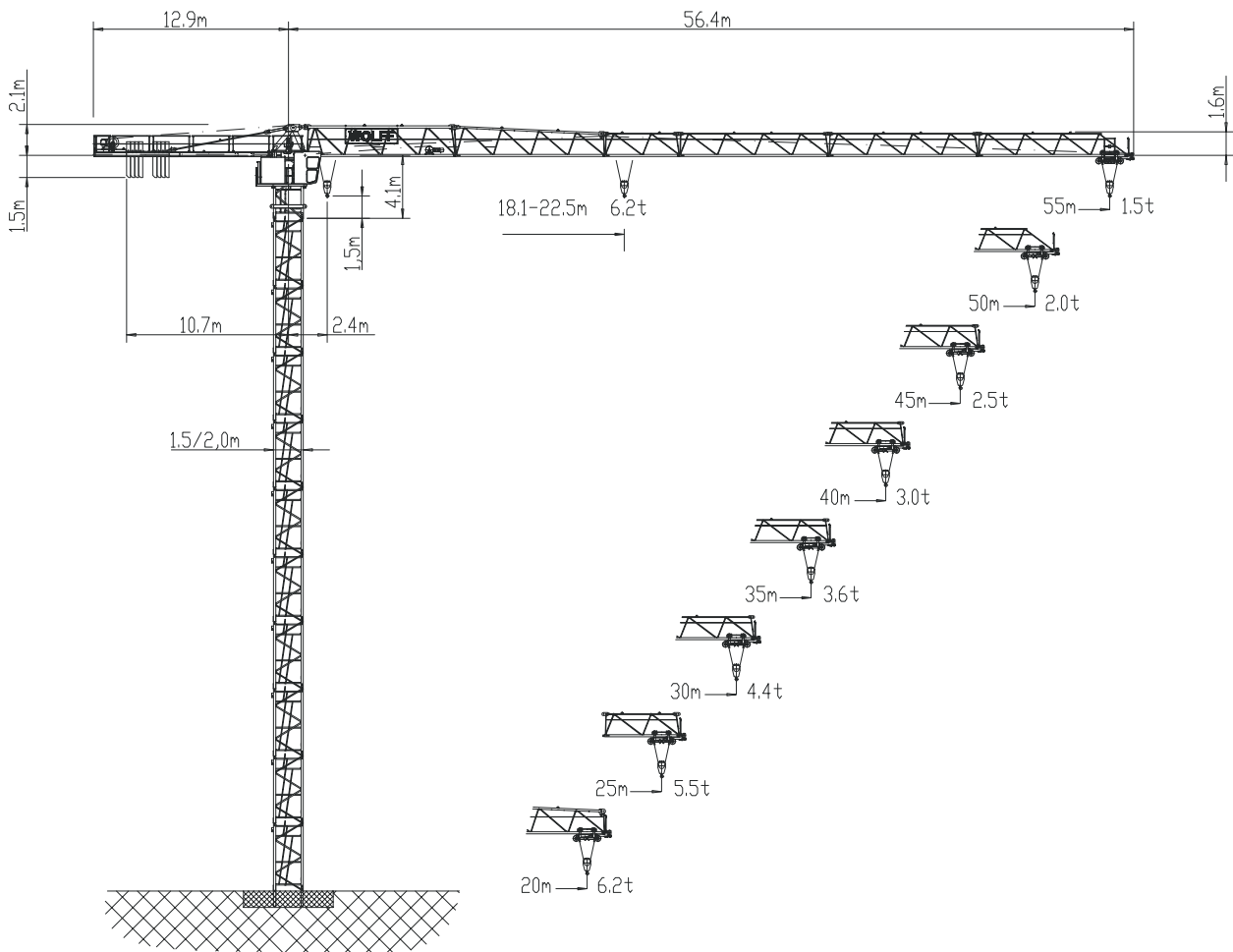

Data WOLFF 5020.6 clear

Item	Data
Crane type	BGL GROUP C.0.10.0112
Design	Overhead travelling crane with top slewing trolley jib, with climbing feature
Type of setup	Stationary or travelling
Basis of calculation	EN
Payload torque	max. 1400 kN/m
Hoist winch	Hw 628FU

1.2 Schedule drawing, WOLFF 5020.8clear

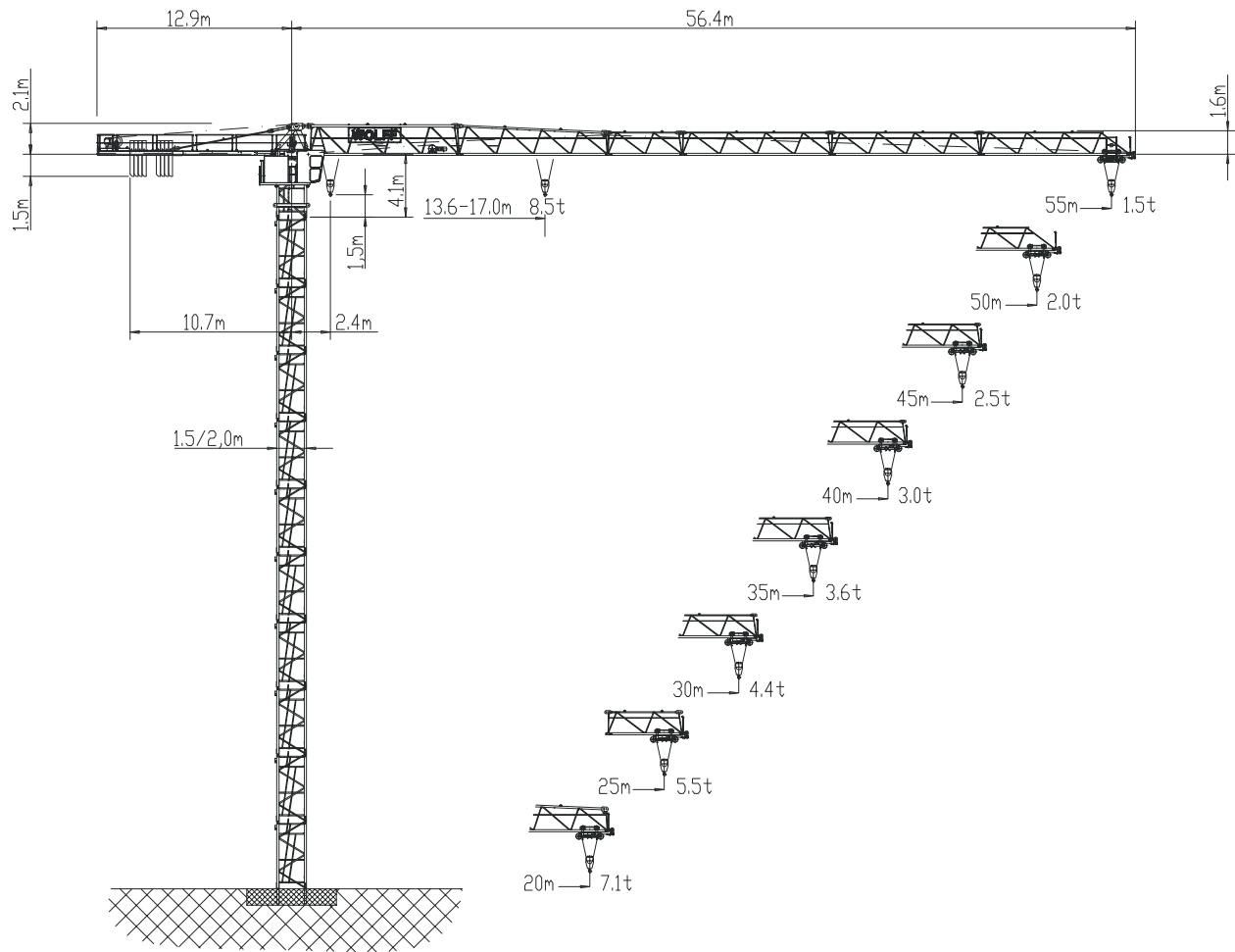

Data WOLFF 5020.8 clear

Item	Data
Crane type	BGL C.0.10.0112
Design	Overhead travelling crane with top slewing trolley jib, with climbing feature
Type of setup	Stationary or travelling
Basis of calculation	EN
Payload torque	max. 1440 kN/m
Hoist winch	Hw 845FU

2 Load carrying capacities

2.1 Table of load carrying capacities, WOLFF 5020.6 clear (6.2 t)

6.2 t		Operating radius [m]	10.0	15.0	20.0	22.5	25.0	27.5	30.0	32.5	35.0	37.5	40.0	42.5	45.0	47.5	50.0	52.5	55.0	
JL [m]	55	2.4 - 18.1	6.2	6.2	5.5	4.8	4.3	3.8	3.4	3.1	2.8	2.6	2.4	2.2	2.0	1.9	1.7	1.6	1.5	LC-C [t]
	52.5	2.4 - 19.5	6.2	6.2	6.0	5.3	4.7	4.2	3.8	3.4	3.1	2.8	2.6	2.4	2.2	2.1	1.9	1.8		
	50	2.4 - 20.0	6.2	6.2	6.2	5.4	4.8	4.3	3.9	3.5	3.2	2.9	2.7	2.5	2.3	2.1	2.0			
	47.5	2.4 - 20.4	6.2	6.2	6.2	5.5	4.9	4.4	4.0	3.6	3.3	3.0	2.8	2.6	2.4	2.2				
	45	2.4 - 21.2	6.2	6.2	6.2	5.8	5.1	4.6	4.2	3.8	3.4	3.2	2.9	2.7	2.5					
	42.5	2.4 - 21.3	6.2	6.2	6.2	5.8	5.2	4.6	4.2	3.8	3.5	3.2	2.9	2.7						
	40	2.4 - 21.7	6.2	6.2	6.2	6.0	5.3	4.7	4.3	3.9	3.5	3.3	3.0							
	37.5	2.4 - 22.0	6.2	6.2	6.2	6.0	5.4	4.8	4.3	3.9	3.6	3.3								
	35	2.4 - 22.0	6.2	6.2	6.2	6.0	5.4	4.8	4.3	3.9	3.6									
	32.5	2.4 - 22.3	6.2	6.2	6.2	6.1	5.4	4.9	4.4	4.0										
	30	2.4 - 22.3	6.2	6.2	6.2	6.1	5.4	4.9	4.4											
	27.5	2.4 - 22.4	6.2	6.2	6.2	6.2	5.5	4.9												
	25	2.4 - 22.5	6.2	6.2	6.2	6.2	5.5													
	22.5	2.4 - 22.5	6.2	6.2	6.2	6.2														
	20	2.4 - 20.0	6.2	6.2	6.2															
JL			Jib length																	
LCC			Load carrying capacity																	

The load carrying capacity is related to a hook range of 42.0 m. Hook ranges greater than that reduce the maximum load carrying capacity by the weight of the additional hoisting ropes (double-reeving mode = 2.5 kg per meter of the hook range).

2.2 Table of load carrying capacities (kg) in meter intervals, WOLFF 5020.6 clear (6.2 t, double reeving mode)

Operating radius [m]	Jib length [m]														
	20	22.5	25	27.5	30	32.5	35	37.5	40	42.5	45	47.5	50	52.5	55
10	6200	6200	6200	6200	6200	6200	6200	6200	6200	6200	6200	6200	6200	6200	6200
11	6200	6200	6200	6200	6200	6200	6200	6200	6200	6200	6200	6200	6200	6200	6200
12	6200	6200	6200	6200	6200	6200	6200	6200	6200	6200	6200	6200	6200	6200	6200
13	6200	6200	6200	6200	6200	6200	6200	6200	6200	6200	6200	6200	6200	6200	6200
14	6200	6200	6200	6200	6200	6200	6200	6200	6200	6200	6200	6200	6200	6200	6200
15	6200	6200	6200	6200	6200	6200	6200	6200	6200	6200	6200	6200	6200	6200	6200
16	6200	6200	6200	6200	6200	6200	6200	6200	6200	6200	6200	6200	6200	6200	6200
17	6200	6200	6200	6200	6200	6200	6200	6200	6200	6200	6200	6200	6200	6200	6200
18	6200	6200	6200	6200	6200	6200	6200	6200	6200	6200	6200	6200	6200	6200	6200
19	6200	6200	6200	6200	6200	6200	6200	6200	6200	6200	6200	6200	6200	6200	5860
20	6200	6200	6200	6200	6200	6200	6200	6200	6200	6200	6200	6200	6200	6030	5530
21		6200	6200	6200	6200	6200	6200	6200	6200	6200	6200	5990	5870	5700	5220
22		6200	6200	6200	6200	6200	6200	6190	6110	5960	5950	5680	5560	5400	4950
22.5		6200	6200	6170	6130	6130	6040	6030	5960	5810	5800	5530	5420	5270	4820
23			6050	6020	5980	5980	5900	5880	5810	5670	5660	5400	5290	5130	4700
24			5760	5730	5700	5700	5620	5610	5530	5400	5390	5140	5030	4890	4470
25			5500	5470	5440	5440	5360	5350	5280	5150	5140	4900	4800	4660	4260
26				5230	5200	5200	5120	5110	5050	4920	4910	4680	4580	4450	4070
27				5010	4980	4980	4900	4890	4830	4710	4700	4480	4390	4260	3890
27.5				4900	4870	4870	4800	4790	4730	4610	4600	4380	4290	4160	3800
28					4770	4770	4700	4690	4630	4510	4500	4290	4200	4080	3720
29					4580	4580	4510	4500	4440	4330	4320	4110	4030	3910	3560
30					4400	4400	4330	4330	4270	4160	4150	3950	3870	3750	3420
31						4230	4170	4160	4100	4000	3990	3800	3720	3600	3280
32						4080	4010	4000	3950	3850	3840	3650	3580	3470	3150
32.5						4000	3940	3930	3880	3780	3770	3580	3510	3400	3090
33							3870	3860	3810	3710	3700	3520	3440	3340	3030
34							3730	3720	3670	3580	3570	3390	3320	3210	2920
35							3600	3590	3540	3450	3440	3270	3200	3100	2810
36								3470	3420	3330	3330	3160	3090	2990	2710
37								3360	3310	3220	3210	3050	2980	2890	2620
37.5								3300	3250	3170	3160	3000	2930	2840	2570
38									3200	3110	3110	2950	2880	2790	2530
39									3100	3010	3010	2850	2790	2700	2440
40									3000	2920	2910	2760	2700	2610	2360
41										2830	2820	2680	2610	2530	2290
42										2740	2740	2590	2530	2450	2210
42.5										2700	2690	2550	2490	2410	2180
43											2650	2510	2460	2370	2140
44											2580	2440	2380	2300	2080
45											2500	2370	2310	2230	2010
46												2300	2240	2170	1950
47												2230	2180	2100	1890
47.5												2200	2150	2070	1860
48													2120	2040	1840
49													2060	1990	1780
50													2000	1930	1730
51														1880	1680
52														1830	1630
52.5														1800	1610
53															1590
54															1540
55															1500

2.3 Table of load carrying capacities, WOLFF 5020.8 clear (8.5 t)







 8.5 t		Operating radius [m]	10.0	15.0	20.0	22.5	25.0	27.5	30.0	32.5	35.0	37.5	40.0	42.5	45.0	47.5	50.0	52.5	55.0	LCC [t]
JL [m]	55	2.4 - 13.6	8.5	7.6	5.5	4.8	4.3	3.8	3.4	3.1	2.8	2.6	2.4	2.2	2.0	1.9	1.7	1.6	1.5	
	52.5	2.4 - 14.7	8.5	8.3	6.0	5.3	4.7	4.2	3.8	3.4	3.1	2.8	2.6	2.4	2.2	2.1	1.9	1.8		
	50	2.4 - 15.1	8.5	8.5	6.2	5.4	4.8	4.3	3.9	3.5	3.2	2.9	2.7	2.5	2.3	2.1	2.0			
	47.5	2.4 - 15.3	8.5	8.5	6.3	5.5	4.9	4.4	4.0	3.6	3.3	3.0	2.8	2.6	2.4	2.2				
	45	2.4 - 16.0	8.5	8.5	6.6	5.8	5.1	4.6	4.2	3.8	3.4	3.2	2.9	2.7	2.5					
	42.5	2.4 - 16.0	8.5	8.5	6.6	5.8	5.2	4.6	4.2	3.8	3.5	3.2	2.9	2.7						
	40	2.4 - 16.3	8.5	8.5	6.8	6.0	5.3	4.7	4.3	3.9	3.5	3.3	3.0							
	37.5	2.4 - 16.5	8.5	8.5	6.9	6.0	5.4	4.8	4.3	3.9	3.6	3.3								
	35	2.4 - 16.6	8.5	8.5	6.9	6.0	5.4	4.8	4.3	3.9	3.6									
	32.5	2.4 - 16.8	8.5	8.5	7.0	6.1	5.4	4.9	4.4	4.0										
	30	2.4 - 16.8	8.5	8.5	7.0	6.1	5.4	4.9	4.4											
	27.5	2.4 - 16.9	8.5	8.5	7.0	6.2	5.5	4.9												
	25	2.4 - 16.9	8.5	8.5	7.1	6.2	5.5													
	22.5	2.4 - 16.9	8.5	8.5	7.1	6.2														
	20	2.4 - 17.0	8.5	8.5	7.1															
	JL		Jib length																	
LCC		Load carrying capacity																		

The load carrying capacity is related to a hook range of 42.0 m. Hook ranges greater than that reduce the maximum load carrying capacity by the weight of the additional hoisting ropes (double-reeving mode = 2.5 kg per meter of the hook range).

2.4 Table of load carrying capacities (kg) in meter intervals, WOLFF 5020.8 clear (8.5 t, double reeving)

Operating radius [m]	Jib length [m]														
	20	22.5	25	27.5	30	32.5	35	37.5	40	42.5	45	47.5	50	52.5	55
10	8500	8500	8500	8500	8500	8500	8500	8500	8500	8500	8500	8500	8500	8500	8500
11	8500	8500	8500	8500	8500	8500	8500	8500	8500	8500	8500	8500	8500	8500	8500
12	8500	8500	8500	8500	8500	8500	8500	8500	8500	8500	8500	8500	8500	8500	8500
13	8500	8500	8500	8500	8500	8500	8500	8500	8500	8500	8500	8500	8500	8500	8500
14	8500	8500	8500	8500	8500	8500	8500	8500	8500	8500	8500	8500	8500	8500	8240
15	8500	8500	8500	8500	8500	8500	8500	8500	8500	8500	8500	8500	8500	8300	7630
16	8500	8500	8500	8500	8500	8500	8500	8500	8500	8500	8480	8110	7950	7730	7110
17	8490	8460	8460	8420	8380	8380	8260	8240	8140	7950	7940	7580	7440	7230	6640
18	7980	7950	7950	7910	7870	7870	7760	7740	7640	7460	7450	7120	6980	6780	6230
19	7520	7490	7490	7450	7410	7410	7310	7290	7200	7030	7020	6700	6570	6380	5860
20	7100	7080	7080	7040	7000	7000	6900	6890	6800	6640	6630	6330	6200	6030	5530
21		6700	6700	6660	6630	6630	6530	6520	6440	6280	6270	5990	5870	5700	5220
22		6360	6360	6330	6290	6290	6200	6190	6110	5960	5950	5680	5560	5400	4950
22.5		6200	6200	6170	6130	6130	6040	6030	5960	5810	5800	5530	5420	5270	4820
23			6050	6020	5980	5980	5900	5880	5810	5670	5660	5400	5290	5130	4700
24			5760	5730	5700	5700	5620	5610	5530	5400	5390	5140	5030	4890	4470
25			5500	5470	5440	5440	5360	5350	5280	5150	5140	4900	4800	4660	4260
26				5230	5200	5200	5120	5110	5050	4920	4910	4680	4580	4450	4070
27				5010	4980	4980	4900	4890	4830	4710	4700	4480	4390	4260	3890
27.5				4900	4870	4870	4800	4790	4730	4610	4600	4380	4290	4160	3800
28					4770	4770	4700	4690	4630	4510	4500	4290	4200	4080	3720
29					4580	4580	4510	4500	4440	4330	4320	4110	4030	3910	3560
30					4400	4400	4330	4330	4270	4160	4150	3950	3870	3750	3420
31						4230	4170	4160	4100	4000	3990	3800	3720	3600	3280
32						4080	4010	4000	3950	3850	3840	3650	3580	3470	3150
32.5						4000	3940	3930	3880	3780	3770	3580	3510	3400	3090
33							3870	3860	3810	3710	3700	3520	3440	3340	3030
34							3730	3720	3670	3580	3570	3390	3320	3210	2920
35							3600	3590	3540	3450	3440	3270	3200	3100	2810
36								3470	3420	3330	3330	3160	3090	2990	2710
37								3360	3310	3220	3210	3050	2980	2890	2620
37.5								3300	3250	3170	3160	3000	2930	2840	2570
38									3200	3110	3110	2950	2880	2790	2530
39									3100	3010	3010	2850	2790	2700	2440
40									3000	2920	2910	2760	2700	2610	2360
41										2830	2820	2680	2610	2530	2290
42										2740	2740	2590	2530	2450	2210
42.5										2700	2690	2550	2490	2410	2180
43											2650	2510	2460	2370	2140
44											2580	2440	2380	2300	2080
45											2500	2370	2310	2230	2010
46												2300	2240	2170	1950
47												2230	2180	2100	1890
47.5												2200	2150	2070	1860
48													2120	2040	1840
49													2060	1990	1780
50													2000	1930	1730
51														1880	1680
52														1830	1630
52.5														1800	1610
53															1590
54															1540
55															1500

3 Tower combinations

	<p>DANGER</p> <p>Usage of incorrect tower combinations. The slewing tower crane may overturn.</p> <ol style="list-style-type: none"> 1) Use the specified tower combinations. 2) If you need another tower combination that is not specified here, please contact WOLFFKRAN to get an approved alternative setup in writing.
	<p>NOTICE</p> <p>All tower combinations apply to free standing slewing tower cranes without climbing gear.</p>
	<p>NOTICE</p> <p>The tower elements TFS 15 are without climbing feature.</p>
	<p>NOTICE</p> <p>The tower elements TFS 20 are without climbing feature.</p>
	<p>NOTICE</p> <p>For tower combination with tower element TV 25 and UV 25 please contact WOLFFKRAN.</p>
	<p>NOTICE</p> <p>When using the UV 15 tower connection, the illustrated TFS 15(.4) and UVA 15.4 tower elements can be replaced by UV 15.4 tower elements. The illustrated hook height remains the same. All other tower elements are to be used as illustrated.</p>
	<p>NOTICE</p> <p>When using the UV 20 tower connection, the illustrated TFS 20(.4) and UVA 20.4 tower elements can be replaced by UV 20.4 tower elements. The illustrated hook height remains the same. All other tower elements are to be used as illustrated.</p>

3.1 Tower combinations on foundation (TFS 15 / UV 15 connection)

Jib length	20 m – 55 m				
Item					
1	4.5 m	TFS 15	TFS 15	TFS 15	TFS 15
2	9.0 m	TFS 15	TFS 15	TFS 15	TFS 15
3	13.5 m	TFS 15	TFS 15.4	TFS 15.4	TFS 15.4
4	18.0 m	TFS 15.4	TFS 15.4	TFS 15.4	TFS 15.4
5	22.5 m	TFS 15.4	TFS 15.4	TFS 15.4	TFS 15.4
6	27.0 m	TFS 15.4	TFS 15.4	TFS 15.4	TFS 15.4
7	31.5 m	TFS 15.4	TFS 15.4	TFS 15.4	TFS 15.4
8	36.0 m	TFS 15.4	UVA 15.4	UVA 15.4	UVA 15.4
9	40.5 m		UV 15.4	UV 15.4	UV 15.4
10	45.0 m		UV 15.4	UV 15.4	UVÜ 15.4
11	49.5 m			UVÜ 15.4	UV 20.4
12	54.0 m			UV 20.4	UV 20.4
13	58.5 m			UV 20.4	TVA 20.4
14	63.0 m				TV 20.4
15	67.5 m				TV 20.4
16	72.0 m				TV 20.4
Foundation		FUA B.4 FUA 93	FUA 120 type C-120	FUA 120 type C-120	FUA 140 type D-140
Tower height [m]		36.0	45.0	58.5	72.0
Hook height above ground [m]		37.5	46.5	60.0	73.5

WOLFFKRAN

Jib length	20 m – 55 m			
Item				
1	4.5 m	TFS 15		
2	9.0 m	TFS 15		
3	13.5 m	TFS 15.4		
4	18.0 m	TFS 15.4		
5	22.5 m	TFS 15.4		
6	27.0 m	TFS 15.4		
7	31.5 m	UVA 15.4		
8	36.0 m	UV 15.4		
9	40.5 m	UV 15.4		
10	45.0 m	UVÜ 15.4		
11	49.5 m	UV 20.4		
12	54.0 m	TVA 20.4		
13	58.5 m	TV 20.4		
14	63.0 m	TV 20.4		
15	67.5 m	TV 20.4		
16	72.0 m	TV 20.4		
17	73.0 m	VR 2023		
18	77.5 m	TV 23		
Foundation		FUA 140 type D-140		
Tower height [m]		77.5		
Hook height above ground [m]		79.0		

Jib length	20 m – 55 m			
Item				
1	4.5 m	TFS 15		
2	9.0 m	TFS 15		
3	13.5 m	TFS 15.4		
4	18.0 m	TFS 15.4		
5	22.5 m	TFS 15.4		
6	27.0 m	TFS 15.4		
7	31.5 m	UVA 15.4		
8	36.0 m	UV 15.4		
9	40.5 m	UVÜ 15.4		
10	45.0 m	UV 20.4		
11	49.5 m	UV 20.4		
12	54.0 m	TVA 20.4		
13	58.5 m	TV 20.4		
14	63.0 m	TV 20.4		
15	67.5 m	TV 20.4		
16	68.5 m	VR 2023		
17	73.0 m	TV 23		
18	77.5 m	TV 23		
19	82.0 m	HTA 23		
20	86.5 m	HT 23		
21	91.0 m	HT 23		
Foundation		FUA G 160		
Tower height [m]		91.0		
Hook height above ground [m]		92.5		

Jib length	20 m – 55 m			
Item				
1	4.5 m	TFS 15		
2	9.0 m	TFS 15		
3	13.5 m	TFS 15.4		
4	18.0 m	TFS 15.4		
5	22.5 m	TFS 15.4		
6	27.0 m	TFS 15.4		
7	31.5 m	UVA 15.4		
8	36.0 m	UV 15.4		
9	40.5 m	UVÜ 15.4		
10	45.0 m	UV 20.4		
11	49.5 m	TVA 20.4		
12	54.0 m	TV 20.4		
13	58.5 m	TV 20.4		
14	63.0 m	TV 20.4		
15	67.5 m	TV 20.4		
16	68.5 m	VR 2023		
17	73.0 m	TV 23		
18	77.5 m	HTA 23		
19	82.0 m	HT 23		
20	86.5 m	HT 23		
21	97.8 m	BT 23		
Foundation		FUA G 210		
Tower height [m]		97.8		
Hook height above ground [m]		99.3		

3.2 Tower combinations on foundation (TFS 20 / UV 20 connection)

Jib length	20 m – 55 m				
Item					
1	4.5 m	TFS 20	TFS 20	TFS 20	TFS 20
2	9.0 m	TFS 20	TFS 20	TFS 20	TFS 20
3	13.5 m	TFS 20	TFS 20	TFS 20	TFS 20
4	18.0 m	TFS 20	TFS 20	TFS 20	TFS 20
5	22.5 m	TFS 20	TFS 20	TFS 20	TFS 20
6	27.0 m	TFS 20	TFS 20	TFS 20	TFS 20
7	31.5 m	TFS 20	TFS 20	TFS 20.4	TFS 20.4
8	36.0 m	TFS 20	TFS 20.4	TFS 20.4	TFS 20.4
9	40.5 m		TFS 20.4	TFS 20.4	TFS 20.4
10	45.0 m		TFS 20.4	TFS 20.4	UVA 20.4
11	49.5 m			UVA 20.4	UV 20.4
12	54.0 m			UV 20.4	UV 20.4
13	58.5 m			UV 20.4	TVA 20.4
14	63.0 m				TV 20.4
15	67.5 m				TV 20.4
16	72.0 m				TV 20.4
Foundation		FUA B.4 FUA 93	FUA B.4 FUA 93	FUA 120 type C-120	FUA 140 type C-140
Tower height [m]		36.0	45.0	58.5	72.0
Hook height above ground [m]		37.5	46.5	60.0	73.5

Jib length	20 m – 55 m			
Item				
1	4.5 m	TFS 20		
2	9.0 m	TFS 20		
3	13.5 m	TFS 20		
4	18.0 m	TFS 20		
5	22.5 m	TFS 20		
6	27.0 m	TFS 20.4		
7	31.5 m	TFS 20.4		
8	36.0 m	TFS 20.4		
9	40.5 m	TFS 20.4		
10	45.0 m	UVA 20.4		
11	49.5 m	UV 20.4		
12	54.0 m	TVA 20.4		
13	58.5 m	TV 20.4		
14	63.0 m	TV 20.4		
15	67.5 m	TV 20.4		
16	72.0 m	TV 20.4		
17	73.0 m	VR 2023		
18	77.5 m	TV 23		
Foundation		FUA 140 type C-140		
Tower height [m]		77.5		
Hook height above ground [m]		79.0		

Jib length	20 m – 55 m			
Item				
1	4.5 m	TFS 20		
2	9.0 m	TFS 20		
3	13.5 m	TFS 20		
4	18.0 m	TFS 20		
5	22.5 m	TFS 20		
6	27.0 m	TFS 20.4		
7	31.5 m	TFS 20.4		
8	36.0 m	TFS 20.4		
9	40.5 m	UVA 20.4		
10	45.0 m	UV 20.4		
11	49.5 m	TVA 20.4		
12	54.0 m	TV 20.4		
13	58.5 m	TV 20.4		
14	63.0 m	TV 20.4		
15	67.5 m	TV 20.4		
16	68.5 m	VR 2023		
17	73.0 m	TV 23		
18	77.5 m	HTA 23		
19	82.0 m	HT 23		
20	86.5 m	HT 23		
21	91.0 m	HT 23		
Foundation		FUA G 160		
Tower height [m]		91.0		
Hook height above ground [m]		92.5		

3.3 Tower combinations on cross frame (TFS 15 / UV 15 connection)

Jib length	20 m – 55 m				
Item					
1	4.5 m	TFS 15	TFS 15	TFS 15	TFS 15
2	9.0 m	TFS 15	TFS 15	TFS 15	TFS 15
3	13.5 m	TFS 15	TFS 15	TFS 15	TFS 15
4	18.0 m	TFS 15.4	TFS 15.4	TFS 15.4	TFS 15.4
5	22.5 m	TFS 15.4	TFS 15.4	TFS 15.4	TFS 15.4
6	27.0 m	TFS 15.4	TFS 15.4	TFS 15.4	TFS 15.4
7	31.5 m	TFS 15.4	TFS 15.4	TFS 15.4	TFS 15.4
8	36.0 m		UVA 15.4	TFS 15.4	TFS 15.4
9	40.5 m		UVÜ 15.4	UVA 15.4	UVA 15.4
Substructure		KR 6-40	KR 800-5 KR 800-6	KRV 7-32	KRV 7-32/46 KR 8-46
[m x m]		4.0 x 4.0	5.0 x 5.0 6.0 x 6.0	3.2 x 3.2	4.6 x 4.6
Substructure height [m]		0.7	0.9	0.8	0.9
Tower height [m]		32.2	41.4	41.3	41.4
Hook height above ground [m]		33.7	42.9	42.8	42.9

Jib length	20 m – 55 m			
Item				
1	4.5 m	TFS 15	TFS 15	TFS 15
2	9.0 m	TFS 15	TFS 15	TFS 15
3	13.5 m	TFS 15.4	TFS 15.4	TFS 15.4
4	18.0 m	TFS 15.4	TFS 15.4	TFS 15.4
5	22.5 m	TFS 15.4	TFS 15.4	TFS 15.4
6	27.0 m	TFS 15.4	TFS 15.4	TFS 15.4
7	31.5 m	TFS 15.4	TFS 15.4	TFS 15.4
8	36.0 m	UVA 15.4	UVA 15.4	UVA 15.4
9	40.5 m	UV 15.4	UV 15.4	UV 15.4
10	45.0 m	UVÜ 15.4	UVÜ 15.4	UVÜ 15.4
11	49.5 m	UV 20.4	UV 20.4	UV 20.4
12	54.0 m	UV 20.4	UV 20.4	UV 20.4
13	58.5 m	TVA 20.4	TVA 20.4	TVA 20.4
14	63.0 m	TV 20.4	TV 20.4	TV 20.4
15	67.5 m		TV 20.4	TV 20.4
16	72.0 m		TVÜ 20.4	TV 20.4
Substructure		KR 10-46 KR 10-46/60	KR 1000-8	KR 12-60 KR 12-60/80
[m x m]		4.6 x 4.6 6.0 x 6.0	8.0 x 8.0	6.0 x 6.0 8.0 x 8.0
Substructure height [m]		1.2	1.2	1.4
Tower height [m]		64.2	73.2	73.4
Hook height above ground [m]		65.7	74.7	74.9

Jib length	20 m – 55 m				
Item					
1	4.5 m	TFS 15	TFS 15	TFS 15	
2	9.0 m	TFS 15	TFS 15	TFS 15	
3	13.5 m	TFS 15.4	TFS 15.4	TFS 15.4	
4	18.0 m	TFS 15.4	TFS 15.4	TFS 15.4	
5	22.5 m	TFS 15.4	TFS 15.4	TFS 15.4	
6	27.0 m	TFS 15.4	TFS 15.4	TFS 15.4	
7	31.5 m	UVA 15.4	UVA 15.4	UVA 15.4	
8	36.0 m	UV 15.4	UV 15.4	UV 15.4	
9	40.5 m	UVÜ 15.4	UVÜ 15.4	UVÜ 15.4	
10	45.0 m	UV 20.4	UV 20.4	UV 20.4	
11	49.5 m	UV 20.4	UV 20.4	UV 20.4	
12	54.0 m	TVA 20.4	TVA 20.4	TVA 20.4	
13	58.5 m	TV 20.4	TV 20.4	TV 20.4	
14	63.0 m	TV 20.4	TV 20.4	TV 20.4	
15	67.5 m	TV 20.4	TV 20.4	TV 20.4	
16	68.5 m	VR 2023	VR 2023	VR 2023	
17	73.0 m	TV 23	TV 23	TV 23	
18	77.5 m	TV 23	TV 23	TV 23	
19	82.0 m	HTA 23	HTA 23	HTA 23	
20	86.5 m		HT 23	HT 23	
21	91.0 m			HT 23	
Substructure		KR 12-60	KR 12-60/80	KR 16-80 KR 16-80/100	
[m x m]		6.0 x 6.0	8.0 x 8.0	8.0 x 8.0 10.0 x 10.0	
Substructure height [m]		1.4	1.4	1.8	
Tower height [m]		83.4	87.9	92.8	
Hook height above ground [m]		84.9	89.4	94.3	

Jib length	20 m – 55 m			
Item				
1	4.5 m	TFS 15		
2	9.0 m	TFS 15		
3	13.5 m	TFS 15.4		
4	18.0 m	TFS 15.4		
5	22.5 m	TFS 15.4		
6	27.0 m	TFS 15.4		
7	31.5 m	UVA 15.4		
8	36.0 m	UV 15.4		
9	40.5 m	UVÜ 15.4		
10	45.0 m	UV 20.4		
11	49.5 m	TVA 20.4		
12	54.0 m	TV 20.4		
13	58.5 m	TV 20.4		
14	63.0 m	TV 20.4		
15	64.0 m	VR 2023		
16	68.5 m	TV 23		
17	73.0 m	TV 23		
18	77.5 m	HTA 23		
19	82.0 m	HT 23		
20	86.5 m	HT 23		
21	87.7 m	VR 23/25-29		
22	92.2 m	UV 29		
23	102.2 m	BT 29		
Substructure		KR 16-80 KR 16-80/100		
[m x m]		8.0 x 8.0 10.0 x 10.0		
Substructure height [m]		1.8		
Tower height [m]		104.0		
Hook height above ground [m]		105.5		

3.4 Tower combinations on cross frame (TFS 20 / UV 20 connection)

Jib length	20 m – 55 m				
Item					
1	4.5 m	TFS 20	TFS 20	TFS 20	
2	9.0 m	TFS 20	TFS 20	TFS 20	
3	13.5 m	TFS 20	TFS 20	TFS 20	
4	18.0 m	TFS 20	TFS 20	TFS 20	
5	22.5 m	TFS 20	TFS 20	TFS 20	
6	27.0 m	TFS 20	TFS 20	TFS 20	
7	31.5 m	TFS 20	TFS 20	TFS 20.4	
8	36.0 m	TFS 20.4	TFS 20.4	TFS 20.4	
9	40.5 m	TFS 20.4	TFS 20.4	TFS 20.4	
10	45.0 m			UVA 20.4	
11	49.5 m			UV 20.4	
12	54.0 m			UV 20.4	
13	58.5 m			TVA 20.4	
14	63.0 m			TV 20.4	
Substructure		KR 800-5 KR 800-6	KRV 7-32/46 KR 8-46	KR 10-46 KR 10-46/60	
[m x m]		5.0 x 5.0 6.0 x 6.0	4.6 x 4.6	4.6 x 4.6 6.0 x 6.0	
Substructure height [m]		0.9	0.9	1.2	
Tower height [m]		41.4	41.4	64.2	
Hook height above ground [m]		42.9	42.9	65.7	

Jib length	20 m – 55 m			
Item				
1	4.5 m	TFS 20	TFS 20	
2	9.0 m	TFS 20	TFS 20	
3	13.5 m	TFS 20	TFS 20	
4	18.0 m	TFS 20	TFS 20	
5	22.5 m	TFS 20	TFS 20	
6	27.0 m	TFS 20	TFS 20	
7	31.5 m	TFS 20.4	TFS 20.4	
8	36.0 m	TFS 20.4	TFS 20.4	
9	40.5 m	TFS 20.4	TFS 20.4	
10	45.0 m	UVA 20.4	UVA 20.4	
11	49.5 m	UV 20.4	UV 20.4	
12	54.0 m	UV 20.4	UV 20.4	
13	58.5 m	TVA 20.4	TVA 20.4	
14	63.0 m	TV 20.4	TV 20.4	
15	67.5 m	TV 20.4	TV 20.4	
16	72.0 m	TVÜ 20.4	TV 20.4	
Substructure		KR 1000-8	KR 12-60 KR 12-60/80	
[m x m]		8.0 x 8.0	6.0 x 6.0 8.0 x 8.0	
Substructure height [m]		1.2	1.4	
Tower height [m]		73.2	73.4	
Hook height above ground [m]		74.7	74.9	

Jib length	20 m – 55 m				
Item					
1	4.5 m	TFS 20	TFS 20	TFS 20	
2	9.0 m	TFS 20	TFS 20	TFS 20	
3	13.5 m	TFS 20	TFS 20	TFS 20	
4	18.0 m	TFS 20	TFS 20	TFS 20	
5	22.5 m	TFS 20	TFS 20	TFS 20	
6	27.0 m	TFS 20.4	TFS 20.4	TFS 20.4	
7	31.5 m	TFS 20.4	TFS 20.4	TFS 20.4	
8	36.0 m	TFS 20.4	TFS 20.4	TFS 20.4	
9	40.5 m	UVA 20.4	UVA 20.4	UVA 20.4	
10	45.0 m	UV 20.4	UV 20.4	UV 20.4	
11	49.5 m	UV 20.4	TVA 20.4	TVA 20.4	
12	54.0 m	TVA 20.4	TV 20.4	TV 20.4	
13	58.5 m	TV 20.4	TV 20.4	TV 20.4	
14	63.0 m	TV 20.4	TV 20.4	TV 20.4	
15	67.5 m	TV 20.4	TV 20.4	TV 20.4	
16	68.5 m	VR 2023	VR 2023	VR 2023	
17	73.0 m	TV 23	TV 23	TV 23	
18	77.5 m	HTA 23	HTA 23	HTA 23	
19	82.0 m	HT 23	HT 23	HT 23	
20	86.5 m		HT 23	HT 23	
21	91.0 m			HT 23	
Substructure		KR 12-60	KR 12-60/80	KR 16-80 KR 16-80/100	
[m x m]		6.0 x 6.0	8.0 x 8.0	8.0 x 8.0 10.0 x 10.0	
Substructure height [m]		1.4	1.4	1.8	
Tower height [m]		83.4	87.9	92.8	
Hook height above ground [m]		84.9	89.4	94.3	

3.5 Tower combinations on cross frame element (TFS 15 / UV 15 connection)

Jib length	20 m – 55 m				
Item					
1	4.5 m	TFS 15	TFS 15	TFS 15	TFS 15
2	9.0 m	TFS 15	TFS 15	TFS 15	TFS 15
3	13.5 m	TFS 15	TFS 15	TFS 15	TFS 15.4
4	18.0 m	TFS 15.4	TFS 15.4	TFS 15.4	TFS 15.4
5	22.5 m	TFS 15.4	TFS 15.4	TFS 15.4	TFS 15.4
6	27.0 m	UVA 15.4	TFS 15.4	TFS 15.4	TFS 15.4
7	31.5 m		UVA 15.4	TFS 15.4	TFS 15.4
8	36.0 m			UVA 15.4	UVA 15.4
9	40.5 m			UVÜ 15.4	UV 15.4
10	45.0 m				UVÜ 15.4
11	49.5 m				TVA 20.4
Substructure		KRE 250	KRE 250	KRE 260.1	KRE 260.2
[m x m]		4.5 x 5.44	5.0 x 5.0	5.0 x 6.79 6.0 x 6.0	5.0 x 6.79
Substructure height [m]		4.0	4.0	4.0	4.0
Tower height [m]		31.0	35.5	44.5	53.5
Hook height above ground [m]		32.5	37.0	46.0	55.0

Jib length	20 m – 55 m			
Item				
1	4.5 m	TFS 15	TFS 15	
2	9.0 m	TFS 15	TFS 15	
3	13.5 m	TFS 15.4	TFS 15.4	
4	18.0 m	TFS 15.4	TFS 15.4	
5	22.5 m	TFS 15.4	TFS 15.4	
6	27.0 m	TFS 15.4	TFS 15.4	
7	31.5 m	TFS 15.4	TFS 15.4	
8	36.0 m	UVA 15.4	UVA 15.4	
9	40.5 m	UV 15.4	UV 15.4	
10	45.0 m	UV 15.4	UVÜ 15.4	
11	49.5 m	UVÜ 15.4	UV 20.4	
12	54.0 m	TVA 20.4	UV 20.4	
13	58.5 m		TVA 20.4	
14	63.0 m		TV 20.4	
15	67.5 m		TVÜ 20.4	
16	72.0 m		UVA 25	
Substructure		KRE 260.2	KRE 480	
[m x m]		6.0 x 6.0	8.0 x 8.0	
Substructure height [m]		4.0	4.0	
Tower height [m]		58.0	76.0	
Hook height above ground [m]		59.5	77.5	

3.6 Tower combinations on cross frame element (TFS 20 / UV 20 connection)

Jib length	20 m – 55 m				
Item					
1	4.5 m	TFS 20	TFS 20	TFS 20	TFS 20
2	9.0 m	TFS 20	TFS 20	TFS 20	TFS 20
3	13.5 m	TFS 20	TFS 20	TFS 20	TFS 20
4	18.0 m	TFS 20	TFS 20	TFS 20	TFS 20
5	22.5 m	TFS 20	TFS 20	TFS 20	TFS 20
6	27.0 m	TFS 20	TFS 20	TFS 20	TFS 20
7	31.5 m	TFS 20	TFS 20	TFS 20.4	TFS 20.4
8	36.0 m	TFS 20.4	TFS 20.4	TFS 20.4	TFS 20.4
9	40.5 m	UVA 20.4	TFS 20.4	TFS 20.4	TFS 20.4
10	45.0 m		UVA 20.4	UVA 20.4	UVA 20.4
11	49.5 m		TVA 20.4	UV 20.4	UV 20.4
12	54.0 m			TVA 20.4	UV 20.4
13	58.5 m				TVA 20.4
14	63.0 m				TV 20.4
15	67.5 m				TVÜ 20.4
16	72.0 m				UVA 25
Substructure		KRE 260.1	KRE 260.2	KRE 260.2	KRE 480
[m x m]		5.0 x 6.79 6.0 x 6.0	5.0 x 6.79	6.0 x 6.0	8.0 x 8.0
Substructure height [m]		4.0	4.0	4.0	4.0
Tower height [m]		44.5	53.5	58.0	76.0
Hook height above ground [m]		46.0	55.0	59.5	77.5

3.7 Tower combinations on mobile cross frame (TFS 15 / UV 15 - connection)

Jib length		20 m – 55 m			
Item					
1	4.5 m	TFS 15	TFS 15	TFS 15	
2	9.0 m	TFS 15	TFS 15	TFS 15	
3	13.5 m	TFS 15.4	TFS 15.4	TFS 15.4	
4	18.0 m	TFS 15.4	TFS 15.4	TFS 15.4	
5	22.5 m	TFS 15.4	TFS 15.4	TFS 15.4	
6	27.0 m	TFS 15.4	TFS 15.4	TFS 15.4	
7	31.5 m	UVA 15.4	UVA 15.4	UVA 15.4	
8	36.0 m	UV 15.4	UV 15.4	UV 15.4	
9	40.5 m	UV 15.4	UV 15.4	UV 15.4	
10	45.0 m	UVÜ 15.4	UVÜ 15.4	UVÜ 15.4	
11	49.5 m	UV 20.4	UV 20.4	UV 20.4	
12	54.0 m	UV 20.4	UV 20.4	UV 20.4	
13	58.5 m	TVA 20.4	TVA 20.4	TVA 20.4	
14	63.0 m		TV 20.4	TV 20.4	
15	67.5 m		TV 20.4	TV 20.4	
16	72.0 m		TV 20.4	TV 20.4	
Substructure		KRF 10-46/60	KRF4 12-60/80	KRF6 12-60/80	
[m x m]		6.0 x 6.0	8.0 x 8.0	8.0 x 8.0	
Substructure height [m]		2.0	2.5	2.9	
Tower height [m]		60.5	74.5	74.9	
Hook height above ground [m]		62.0	76.0	76.4	

Jib length	20 m – 55 m			
Item				
1	4.5 m	TFS 15	TFS 15	
2	9.0 m	TFS 15	TFS 15	
3	13.5 m	TFS 15.4	TFS 15.4	
4	18.0 m	TFS 15.4	TFS 15.4	
5	22.5 m	TFS 15.4	TFS 15.4	
6	27.0 m	UVA 15.4	UVA 15.4	
7	31.5 m	UV 15.4	UV 15.4	
8	36.0 m	UV 15.4	UV 15.4	
9	40.5 m	UVÜ 15.4	UVÜ 15.4	
10	45.0 m	UV 20.4	UV 20.4	
11	49.5 m	UV 20.4	UV 20.4	
12	54.0 m	TVA 20.4	TVA 20.4	
13	58.5 m	TV 20.4	TV 20.4	
14	63.0 m	TV 20.4	TV 20.4	
15	67.5 m	TV 20.4	TV 20.4	
16	68.5 m	VR 2023	VR 2023	
17	73.0 m	TV 23	TV 23	
18	77.5 m	TV 23	TV 23	
19	82.0 m	HTA 23	HTA 23	
20	86.5 m		HT 23	
21	91.0 m		HT 23	
Substructure		KRF6 12-60/80	KRF 16-80/100	
[m x m]		8.0 x 8.0	10.0 x 10.0	
Substructure height [m]		2.9	3.3	
Tower height [m]		84.9	94.3	
Hook height above ground [m]		86.4	95.8	

3.8 Tower combinations on mobile cross frame (TFS 20 / UV 20 - connection)

Jib length	20 m – 55 m			
Item				
1	4.5 m	TFS 20	TFS 20	TFS 20
2	9.0 m	TFS 20	TFS 20	TFS 20
3	13.5 m	TFS 20	TFS 20	TFS 20
4	18.0 m	TFS 20	TFS 20	TFS 20
5	22.5 m	TFS 20	TFS 20.4	TFS 20.4
6	27.0 m	TFS 20.4	TFS 20.4	TFS 20.4
7	31.5 m	TFS 20.4	TFS 20.4	TFS 20.4
8	36.0 m	TFS 20.4	TFS 20.4	TFS 20.4
9	40.5 m	TFS 20.4	TFS 20.4	TFS 20.4
10	45.0 m	UVA 20.4	UVA 20.4	UVA 20.4
11	49.5 m	UV 20.4	UV 20.4	UV 20.4
12	54.0 m	UV 20.4	UV 20.4	UV 20.4
13	58.5 m	TVA 20.4	TVA 20.4	TVA 20.4
14	63.0 m		TV 20.4	TV 20.4
15	67.5 m		TV 20.4	TV 20.4
16	72.0 m		TV 20.4	TV 20.4
Substructure		KRF 10-46/60	KRF4 12-60/80	KRF6 12-60/80
[m x m]		6.0 x 6.0	8.0 x 8.0	8.0 x 8.0
Substructure height [m]		2.0	2.5	2.9
Tower height [m]		60.5	74.5	74.9
Hook height above ground [m]		62.0	76.0	76.4

Jib length	20 m – 55 m			
Item				
1	4.5 m	TFS 20	TFS 20	
2	9.0 m	TFS 20	TFS 20	
3	13.5 m	TFS 20	TFS 20	
4	18.0 m	TFS 20	TFS 20	
5	22.5 m	TFS 20.4	TFS 20.4	
6	27.0 m	TFS 20.4	TFS 20.4	
7	31.5 m	TFS 20.4	TFS 20.4	
8	36.0 m	TFS 20.4	TFS 20.4	
9	40.5 m	UVA 20.4	UVA 20.4	
10	45.0 m	UV 20.4	UV 20.4	
11	49.5 m	TVA 20.4	TVA 20.4	
12	54.0 m	TV 20.4	TV 20.4	
13	58.5 m	TV 20.4	TV 20.4	
14	63.0 m	TV 20.4	TV 20.4	
15	67.5 m	TV 20.4	TV 20.4	
16	68.5 m	VR 2023	VR 2023	
17	73.0 m	TV 23	TV 23	
18	77.5 m	HTA 23	HTA 23	
19	82.0 m	HT 23	HT 23	
20	86.5 m		HT 23	
21	91.0 m		HT 23	
Substructure		KRF6 12-60/80	KRF 16-80/100	
[m x m]		8.0 x 8.0	10.0 x 10.0	
Substructure height [m]		2.9	3.3	
Tower height [m]		84.9	94.3	
Hook height above ground [m]		86.4	95.8	

3.9 Tower combinations on bogie truck (TFS 15 / UV 15 - connection)

Jib length	20 m – 55 m				
Item					
1	4.5 m	TFS 15	TFS 15	TFS 15	TFS 15
2	9.0 m	TFS 15	TFS 15	TFS 15	TFS 15
3	13.5 m	TFS 15	TFS 15.4	TFS 15.4	TFS 15.4
4	18.0 m	TFS 15.4	TFS 15.4	TFS 15.4	TFS 15.4
5	22.5 m	UVA 15.4	TFS 15.4	TFS 15.4	TFS 15.4
6	27.0 m		UVA 15.4	TFS 15.4	TFS 15.4
7	31.5 m			UVA 15.4	TFS 15.4
8	36.0 m			UVÜ 15.4	UVA 15.4
9	40.5 m				UVÜ 15.4
Substructure		UW 250	UW 250	UW 260.1	UW 260.1
[m x m]		4.5 x 5.44	5.0 x 5.0	5.0 x 6.79	6.0 x 6.0
Substructure height [m]		4.5	4.5	4.5	4.5
Tower height [m]		27.0	31.5	40.5	45.0
Hook height above ground [m]		28.5	33.0	42.0	46.5

Jib length	20 m – 55 m				
Item					
1	4.5 m	TFS 15	TFS 15	TFS 15	TFS 15
2	9.0 m	TFS 15	TFS 15	TFS 15	TFS 15
3	13.5 m	TFS 15.4	TFS 15.4	TFS 15.4	TFS 15.4
4	18.0 m	TFS 15.4	TFS 15.4	TFS 15.4	TFS 15.4
5	22.5 m	TFS 15.4	TFS 15.4	TFS 15.4	TFS 15.4
6	27.0 m	TFS 15.4	TFS 15.4	TFS 15.4	TFS 15.4
7	31.5 m	UVA 15.4	TFS 15.4	UVA 15.4	UVA 15.4
8	36.0 m	UVÜ 15.4	UVA 15.4	UV 15.4	UV 15.4
9	40.5 m	TVA 20.4	UVÜ 15.4	UV 15.4	UV 15.4
10	45.0 m		TVA 20.4	UVÜ 15.4	UV 15.4
11	49.5 m			TVA 20.4	UVÜ 15.4
12	54.0 m				TVA 20.4
Substructure		UW 260.2	UW 260.2	UW 260.3	UW 260.3
[m x m]		5.0 x 6.79	6.0 x 6.0	5.0 x 6.79	6.0 x 6.0
Substructure height [m]		4.5	4.5	4.5	4.5
Tower height [m]		45.0	49.5	54.0	58.5
Hook height above ground [m]		46.5	51.0	55.5	60.0



Jib length	20 m – 55 m			
Item				
1	4.5 m	TFS 15		
2	9.0 m	TFS 15		
3	13.5 m	TFS 15.4		
4	18.0 m	TFS 15.4		
5	22.5 m	TFS 15.4		
6	27.0 m	TFS 15.4		
7	31.5 m	UVA 15.4		
8	36.0 m	UV 15.4		
9	40.5 m	UV 15.4		
10	45.0 m	UVÜ 15.4		
11	49.5 m	UV 20.4		
12	54.0 m	UV 20.4		
13	58.5 m	TVA 20.4		
14	63.0 m	TV 20.4		
15	67.5 m	TVÜ 20.4		
16	72.0 m	UVA 25		
Substructure		UW 480		
[m x m]		8.0 x 8.0		
Substructure height [m]		5.0		
Tower height [m]		77.0		
Hook height above ground [m]		78.5		



3.10 Tower combinations on bogie truck (TFS 20 / UV 20 - connection)

Jib length	20 m – 55 m				
Item					
1	4.5 m	TFS 20	TFS 20	TFS 20	TFS 20
2	9.0 m	TFS 20	TFS 20	TFS 20	TFS 20
3	13.5 m	TFS 20	TFS 20	TFS 20	TFS 20
4	18.0 m	TFS 20	TFS 20	TFS 20	TFS 20
5	22.5 m	TFS 20	TFS 20	TFS 20	TFS 20
6	27.0 m	TFS 20	TFS 20	TFS 20	TFS 20
7	31.5 m	TFS 20.4	TFS 20.4	TFS 20.4	TFS 20.4
8	36.0 m	UVA 20.4	TFS 20.4	UVA 20.4	TFS 20.4
9	40.5 m		UVA 20.4	TVA 20.4	UVA 20.4
10	45.0 m				TVA 20.4
Substructure		UW 260.1	UW 260.1	UW 260.2	UW 260.2
[m x m]		5.0 x 6.79	6.0 x 6.0	5.0 x 6.79	6.0 x 6.0
Substructure height [m]		4.5	4.5	4.5	4.5
Tower height [m]		40.5	45.0	45.0	49.5
Hook height above ground [m]		42.0	46.5	46.5	51.0

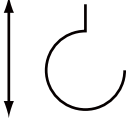
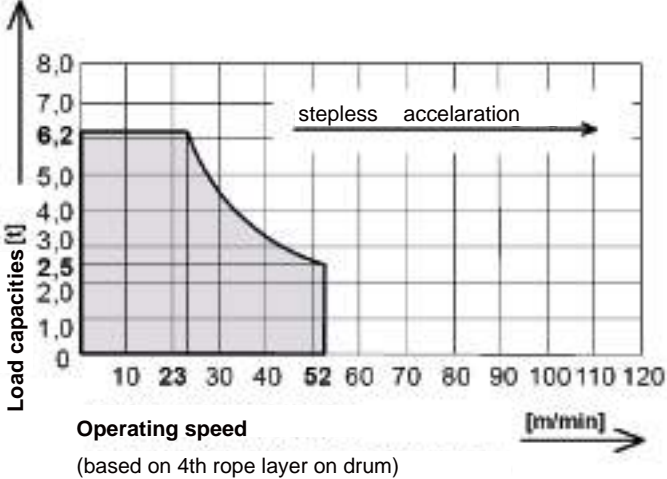
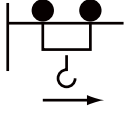
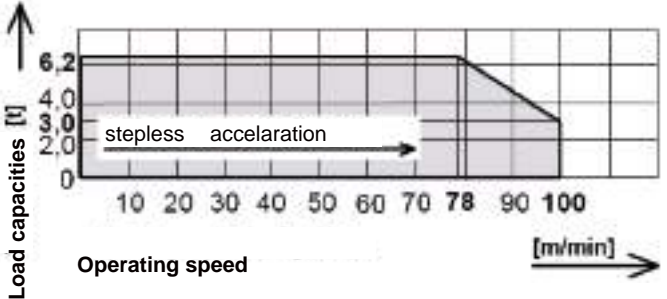

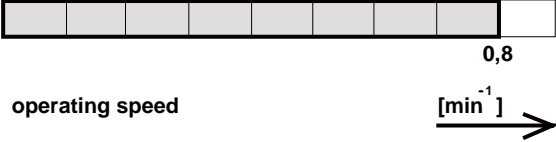

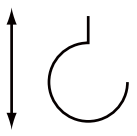
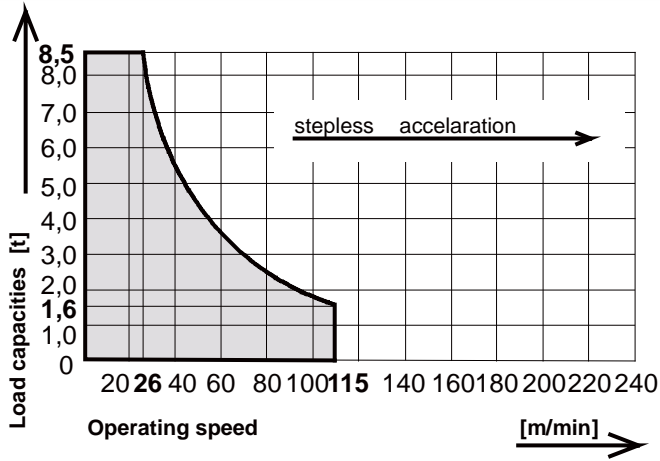
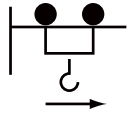
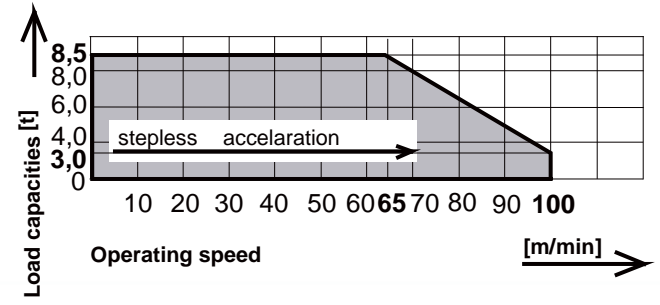

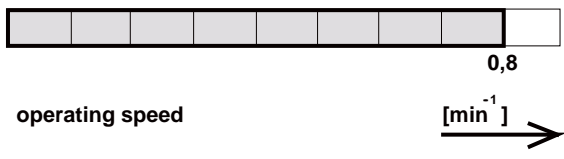

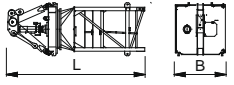
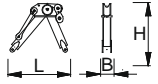
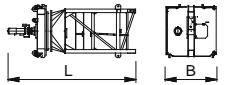
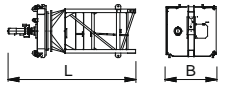

Jib length	20 m – 55 m				
Item					
1	4.5 m	TFS 20	TFS 20	TFS 20	
2	9.0 m	TFS 20	TFS 20	TFS 20	
3	13.5 m	TFS 20	TFS 20	TFS 20	
4	18.0 m	TFS 20	TFS 20	TFS 20	
5	22.5 m	TFS 20	TFS 20	TFS 20	
6	27.0 m	TFS 20.4	TFS 20.4	TFS 20.4	
7	31.5 m	TFS 20.4	TFS 20.4	TFS 20.4	
8	36.0 m	TFS 20.4	TFS 20.4	TFS 20.4	
9	40.5 m	TFS 20.4	TFS 20.4	TFS 20.4	
10	45.0 m	UVA 20.4	UVA 20.4	UVA 20.4	
11	49.5 m	TVA 20.4	UV 20.4	UV 20.4	
12	54.0 m		TVA 20.4	UV 20.4	
13	58.5 m			TVA 20.4	
14	63.0 m			TV 20.4	
15	67.5 m			TVÜ 20.4	
16	72.0 m			UVA 25	
Substructure		UW 260.3	UW 260.3	UW 480	
[m x m]		5.0 x 6.79	6.0 x 6.0	8.0 x 8.0	
Substructure height [m]		4.5	4.5	5.0	
Tower height [m]		54.0	58.5	77.0	
Hook height above ground [m]		55.5	60.0	78.5	

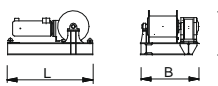

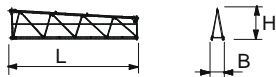
4 Operating speeds

Drive unit [type]	Operating speed Carrying load		Hook travel distance max. [m]	Power [kW]	Total connected wattage [kVA]
Hw628FU	Lifting		190	28	44.0 Total connected load at coincidence factor of 0.7
	 <p>Operating speed [m/min] (based on 4th rope layer on drum)</p>				
KW	Crab movement			4.0	
	 <p>Operating speed [m/min]</p>				
SG	Slewing			7.5	
	 <p>operating speed [min⁻¹]</p>				

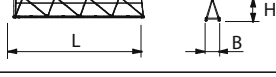
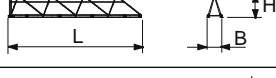
Drive unit [type]	Operating speed Carrying load		Hook travel distance max. [m]	Power [kW]	Total connected wattage [kVA]
Hw845FU	Lifting		190	45	59.0 Total connected load at coincidence factor of 0.7
					
KW	Crab movement			4.0	
					
SG	Slewing			7.5	
					

5 Package list 5020

Quantity	Description	Package	L [m]	W [m]	H [m]	Weight [kg]	Volume [m ³]		
1	Tower head section, complete with slewing frame, ball slew bearing, slewing gear and slip ring system		with TFS 15/UV 15 Sput					5750	25.61
			6.16	2.10	1.98				
	Tower head section upper part with stay parts		with TFS 20/UV 20 Sput					5820	31.31
			6.16	2.10	2.42				
	Tower head section lower part with slewing frame, ball slew bearing, slewing gear and slip ring system		with TFS 15/UV 15 Sput					4860	22.95
			5.52	2.10	1.98				
	Tower head section lower part with slewing frame, ball slew bearing, slewing gear and slip ring system		with TFS 20/UV 20 Sput					4930	28.05
			5.52	2.10	2.42				
1	Driver's cab with driver's cab suspension		4.46	2.11	2.55	2420	22.29		
1	Counter jib with stay parts and standard railings		12.00	2.30	0.64	4410	17.66		
1	Hoist winch platform Hw628FU (incl. 170 m hoisting rope)		2.17	1.50	1.12	2165	3.65		
1	Jib section 1 with traverse gear		10.29	1.19	2.30	2330	28.41		
1	Jib section 3		10.27	1.19	2.08	1310	25.42		
1	Jib section 4		5.25	1.19	1.65	645	10.31		
1	Jib section 5		2.75	1.19	1.65	395	5.40		
1	Jib section 6		10.23	1.19	1.65	1010	20.08		
1	Jib section 7		10.21	1.19	1.64	810	20.05		
1	Jib section 8		10.17	1.19	1.64	705	19.87		
1	Rope swivel cross-beam		0.89	1.10	0.45	105	0.44		
1	Trolley LK 8		1.87	1.42	0.95	295	2.52		

Quantity	Description	Package	L [m]	W [m]	H [m]	Weight [kg]	Volume [m ³]
1	Maintenance cage		0.75	0.58	1.69	55	0.74
1	Snatch block U6 (8)		0.50	0.22	1.11	350	0.12
1	Standard railings		2.60	1.10	0.65	300	1.86
1	Box (small parts)		0.63	0.50	0.38	100	1.12

6 Assembly weights

6.1 Counterweight blocks



NOTICE

The described diagrams of the counterweights and central ballast blocks only show sketches. Have them issue the reinforcement charts by experts.

6.1.1 Counterweight block, 1.2 t

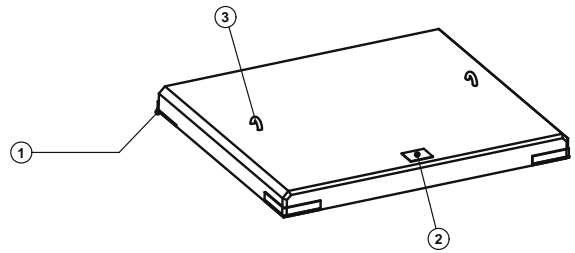
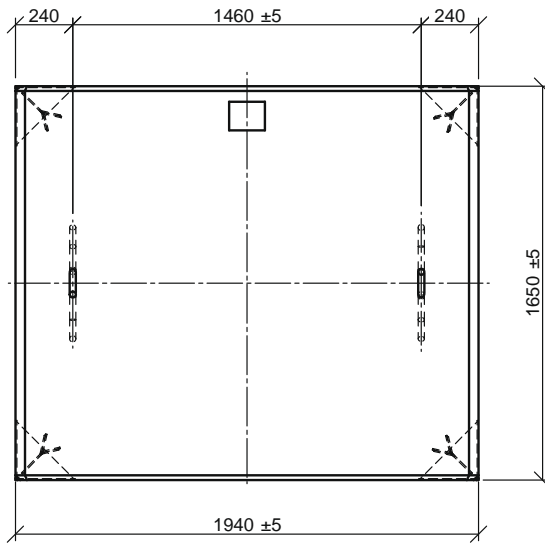
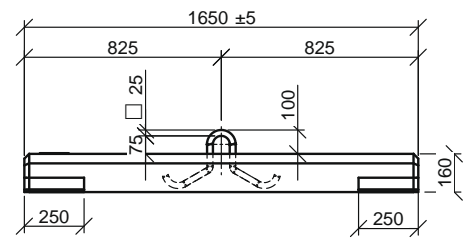

Data counterweight block 1.2 t

Item	Data
Material	Concrete, min. C 20/25
Max. permitted weight tolerance	+/- 3 %
Order number	30047345
1	Corner guard
2	Component identifier
3	Suspension

6.1.2 Counterweight block, 2.05 t

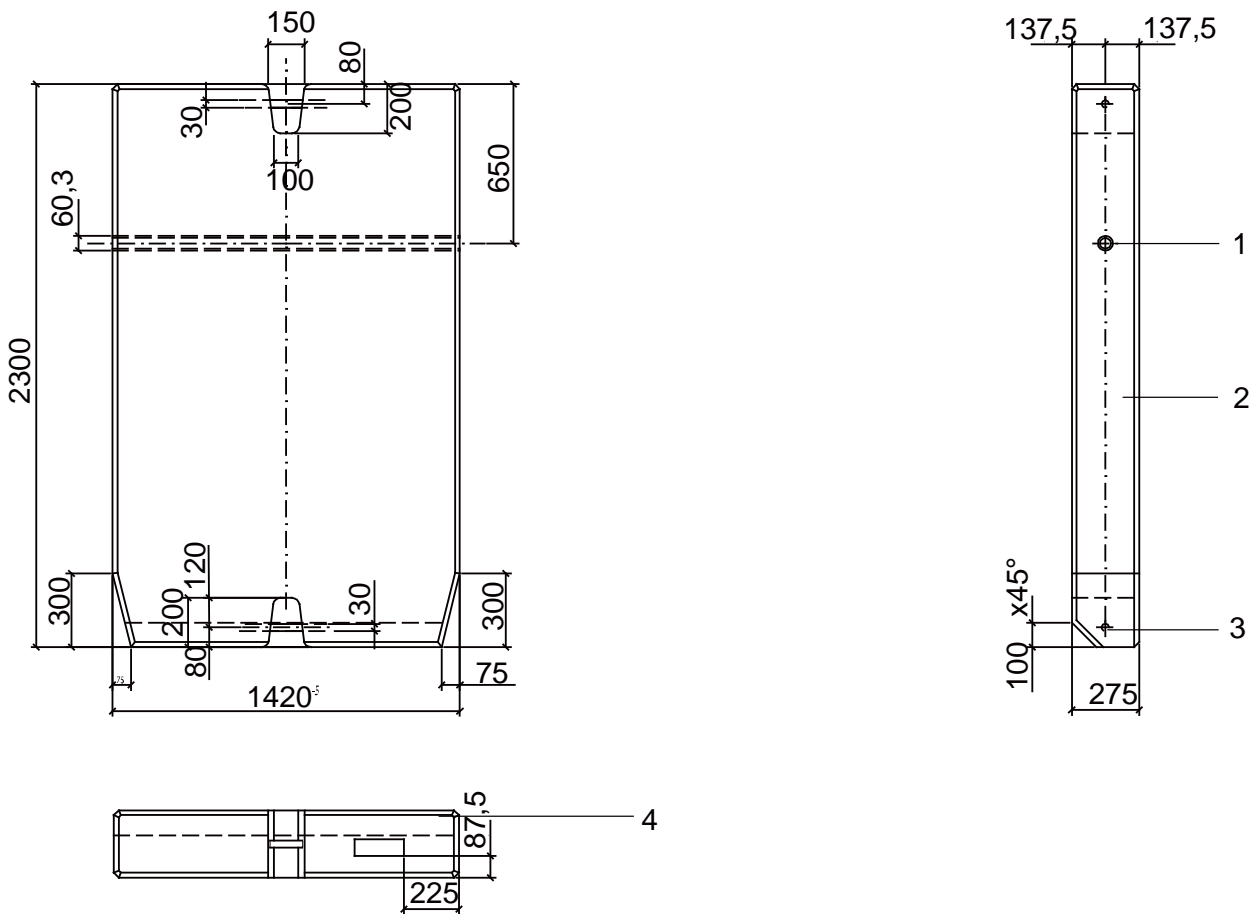

Data counterweight block 2.05t

Item	Data
Material	Concrete, min. C 20/25
Max. permitted weight tolerance	+/- 3 %
Order number	962-2-031954
1	Connection for stub shaft
2	Structural steel reinforcement
3	Suspension
4	Component identifier

6.2 Total weight jib assembly

Trolley jib, complete: Trolley, trolley ropes, snatch block, standard railings and rope swivel crossbeam

Jib length [m]	Weight [kg] WOLFF 5020 clear
55.0	7600
52.5	7300
50.0	6900
47.5	6900
45.0	6900
42.5	6600
40.0	6200
37.5	6300
35.0	6100
32.5	5900
30.0	5500
27.5	5500
25.0	5100
22.5	4800
20.0	4500

6.3 Assembly weight slewing gear

Module	Crane parts	Weight [kg]	
Tower head section complete – Tower connection UV 20 / TV 20 Lower part of tower head section			5820
	▪ Tower head section upper part including brace plates	890	
	▪ Tower head section lower part including slewing frame, ball race bearing, slewing gears, standard railings and slip ring system	4930	
Tower head section complete – Tower connection UV 15/ TFS 15 Lower part of tower head section			5750
	▪ Tower head section upper part including brace plates	890	
	▪ Tower head section lower part including slewing frame, ball race bearing, slewing gears, standard railings and slip ring system	4860	
Operator cabinet platform, complete			2420
	▪ Driver's cab including control cabinet, resistor and driver's cab suspension	2420	
Counter jib with Hw628FU, complete			7785
	▪ Counter jib with brace plates and standard railings	4410	
	▪ Hoist winch platform Hw628FU (incl. 170 m hoisting rope)	2175	
	▪ Concrete counterweight block 1.2 t (below hoist winch platform)	1200	
Counter jib with Hw845FU, complete			7750
	▪ Counter jib with brace plates and standard railings	4410	
	▪ Hoist winch platform Hw845FU (incl. 170 m hoisting rope)	2140	
	▪ Concrete counterweight block 1.2 t (below hoist winch platform)	1200	

6.4 Assembly weight cross frame

Module	Crane parts	Weight [kg]	
Cross frame KR 6-40 (without accessories)			
(4.0 m x 4.0 m)	▪ 4 bolted spigots AZ 93.4	200	3 450
	▪ 4 bolted spigots AZ 93.4 E 15	240	
Cross frame KR 7- 32 (without accessories)			
(3.2 m x 3.2 m)	▪ 4 bolted spigots AZ 85 E 20.5	210	3 350
	▪ 4 bolted spigots AZ 93.4 E 15	240	
	▪ 4 bolted spigots AZ 120 M	292	
Cross frame KR 7 - 32 (without accessories)			
(3.2 m x 3.2 m)	▪ 4 bolted spigots AZ 85 E 20.5	210	3 680
	▪ 4 bolted spigots AZ 93.4 E 15	240	
	▪ 4 bolted spigots AZ 120 M	292	
Cross frame KR 7 - 32/46 (without accessories)			
(4.6 m x 4.6 m)	▪ 4 bolted spigots AZ 85 E 20.5	210	5 090
	▪ 4 bolted spigots AZ 93.4 E 15	240	
	▪ 4 bolted spigots AZ 120 M	292	
Cross frame KR 8- 46 (without accessories)			
(4.6 m x 4.6 m)	▪ 4 bolted spigots AZ 85 E 20.5	210	5 250
	▪ 4 bolted spigots AZ 93.4 E 15	240	
	▪ 4 bolted spigots AZ 120 M	292	
Cross frame KR 10- 46 (without accessories)			
(4.6 m x 4.6 m)	▪ 4 bolted spigots AZR 120 E 15.5	552	7 020
	▪ 4 bolted spigots AZ 140 M	698	
Cross frame KR 16 - 46/ 60 (without accessories)			
(6.0 m x 6.0 m)	▪ 4 bolted spigots AZR 120 E 15.5	552	8 875
	▪ 4 bolted spigots AZ 140 M	698	
Cross frame KR HEB 700 - 4 (without accessories)			
(4.0 m x 4.0 m)	▪ 4 bolted spigots AZ 93.4	240	4 450
Cross frame KR HEB 700 - 5 (without accessories)			
(5.0 m x 5.0 m)	▪ 4 bolted spigots AZ 93.4	240	5 410
Cross frame KR HEB 800 - 5 (without accessories)			
(5.0 m x 5.0 m)	▪ 4 bolted spigots AZ 120 M	292	5 860
Cross frame KR HEB 800 - 6 (without accessories)			
(6.0 m x 6.0 m)	▪ 4 bolted spigots AZ 120 M	292	6 600
Supporting frame SR 150 (without accessories)			
(4.0 m x 4.0 m)	▪ 4 bolted spigots AZ 85 E 20.5	210	5 460
	▪ 4 bolted spigots AZ 93.4 E 15	240	
	▪ 4 bolted spigots AZ 120 M	292	
Cross frame KR 1000- 8 (without accessories)			
(8 m x 8 m)	▪ 4 bolted spigots AZ 140 E	684	14 630

Module	Crane parts	Weight [kg]	
	▪ 4 bolted spigots AZ 156 M	748	
Cross frame KR 16- 80 (without accessories)			21 450
(8 m x 8 m)	▪ 4 bolted spigots AZ 140 E KR 16-80	620	
	▪ 4 bolted spigots AZ 156 M KR 16-80	680	
	▪ 4 bolted spigots AZ 156S M KR 16-80	675	
Cross frame KR 16 - 80 / 100 (without accessories)			25 400
(10 m x 10 m)	▪ 4 bolted spigots AZ 140 E KR 16-80	620	
	▪ 4 bolted spigots AZ 156 M KR 16-80	680	
	▪ 4 bolted spigots AZ 156S M KR 16-80	675	

6.5 Assembly weight cross frame elements

Module	Crane parts	Weight [kg]	
Cross frame element KRE 138 complete			3 800
	▪ Cross frame platform with lifting beam, corner plates and transport locks	2 100	
	▪ Mast base with diagonal struts	1 700	
Cross frame element KRE 250 complete			5 750
	▪ Cross frame platform with hinged section, corner plates and transport locks	2 730	
	▪ Mast base with diagonal struts and tie rods	3 020	
Cross frame element KRE 260.1, complete			8 100
	▪ Cross frame platform with hinged section, corner plates and transport locks	4 320	
	▪ Mast base with diagonal struts and tie rods	3 780	
Cross frame element KRE 260.2, complete			10 900
	▪ Cross frame platform with hinged section, corner plates and transport locks	5 455	
	▪ Mast base with diagonal struts and tie rods	5 445	
Cross frame element KRE 480 complete			24 250
	▪ Mast base	7 100	
	▪ Hinged sections with corner plates	6 250	
	▪ Diagonal struts and ballast carrier	9 260	
	▪ Assembly platform, ladder, and small parts	1 640	

6.6 Assembly weight bogie truck

Module	Crane parts	Weight [kg]	
Bogie truck UW 138, complete			
	▪ Bogie truck platform with lifting beam, spacers and subframes	3 970	
	▪ Mast base with diagonal struts	1 780	
Bogie truck UW 250, complete			
	▪ Bogie truck platform with hinged sections, subframes and transport locks	5 600	
	▪ Mast base with diagonal struts and tie rods	3 200	
Bogie truck UW 260.1, complete			
	▪ Bogie truck platform with hinged sections, subframes and transport locks	7 150	
	▪ Mast base with diagonal struts and tie rods	4 250	
Bogie truck UW 260.2, complete			
	▪ Bogie truck platform with hinged sections, subframes and transport locks	9 810	
	▪ Mast base with diagonal struts and tie rods	4 250	
Bogie truck UW 260.3, complete			
	▪ Bogie truck platform with hinged sections, subframes and transport locks	11 300	
	▪ Mast base with diagonal struts and tie rods	5 900	
Bogie truck UW 480, complete			
	▪ Mast base	7 100	
	▪ Hinged sections with lifting beam and subframes	16 000	
	▪ Diagonal struts and ballast carrier	9 260	
	▪ Assembly platform, ladder, and small parts	1 640	

6.7 Hook height above ground required for mobile cranes

For information about the height of the WOLFF slewing tower crane, refer to Tower combinations [Z].

NOTICE! During assembly, allowances must be made for level differences (mobile crane to base of the slewing tower crane).

Hook height above ground required for mobile cranes (X) = height of the WOLFF slewing tower crane (A) + clearance of 12 (B).

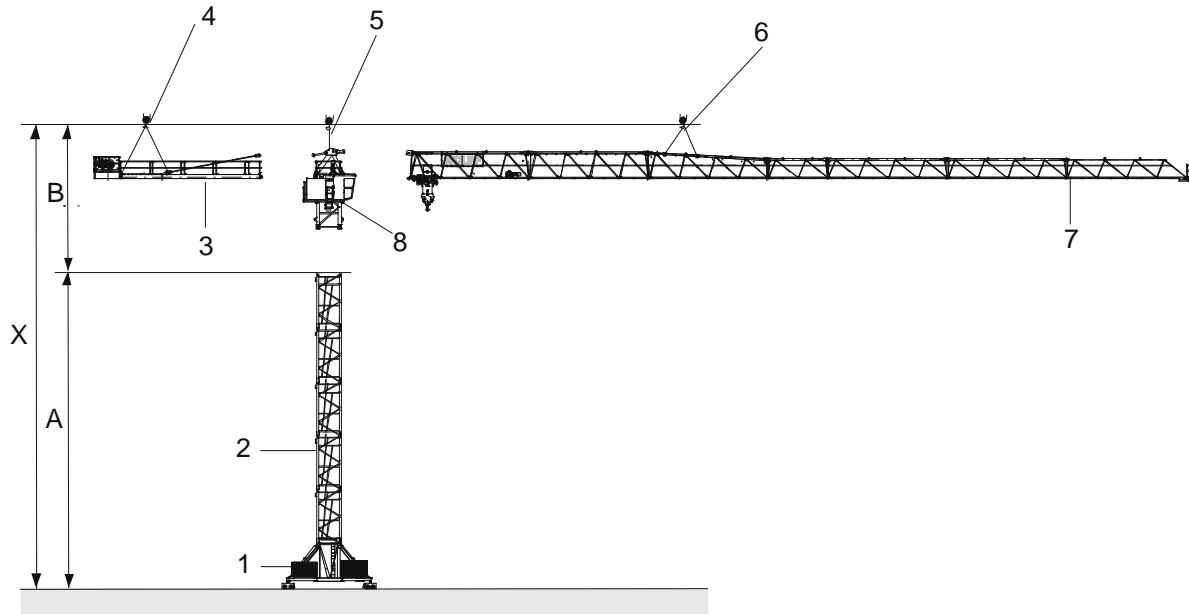

Exemplary illustration

[A]	Height of the WOLFF slewing tower crane	[B]	Clearance 12 m
[X]	Hook height above ground required for the mobile crane		
1	Undercarriage	5	Single-point lifting tackle (2 m with shackle)
2	Tower element	6	Four-point lifting tackle (4 m with shackle)
3	Counter jib, complete	7	Jib, complete
4	Four-point lifting tackle (with shackle)	8	Tower head section, complete

(see also):

- Tower combinations [Z]

7 Assembly diagrams

7.1 Jib attachment diagram

	NOTICE
	For jib assembly, use a Four-point lifting tackle (4 m with shackle).

Length of jib elements

Item	in [m]
Trolley jib elements 1, 3, 6, 7 and 8	10.0
Trolley jib element 4	5.0
Trolley jib element 5	2.5
Rope swivel crossbeam	0.51

7.1.1 Trolley jib - attachment diagram 55 m to 45 m

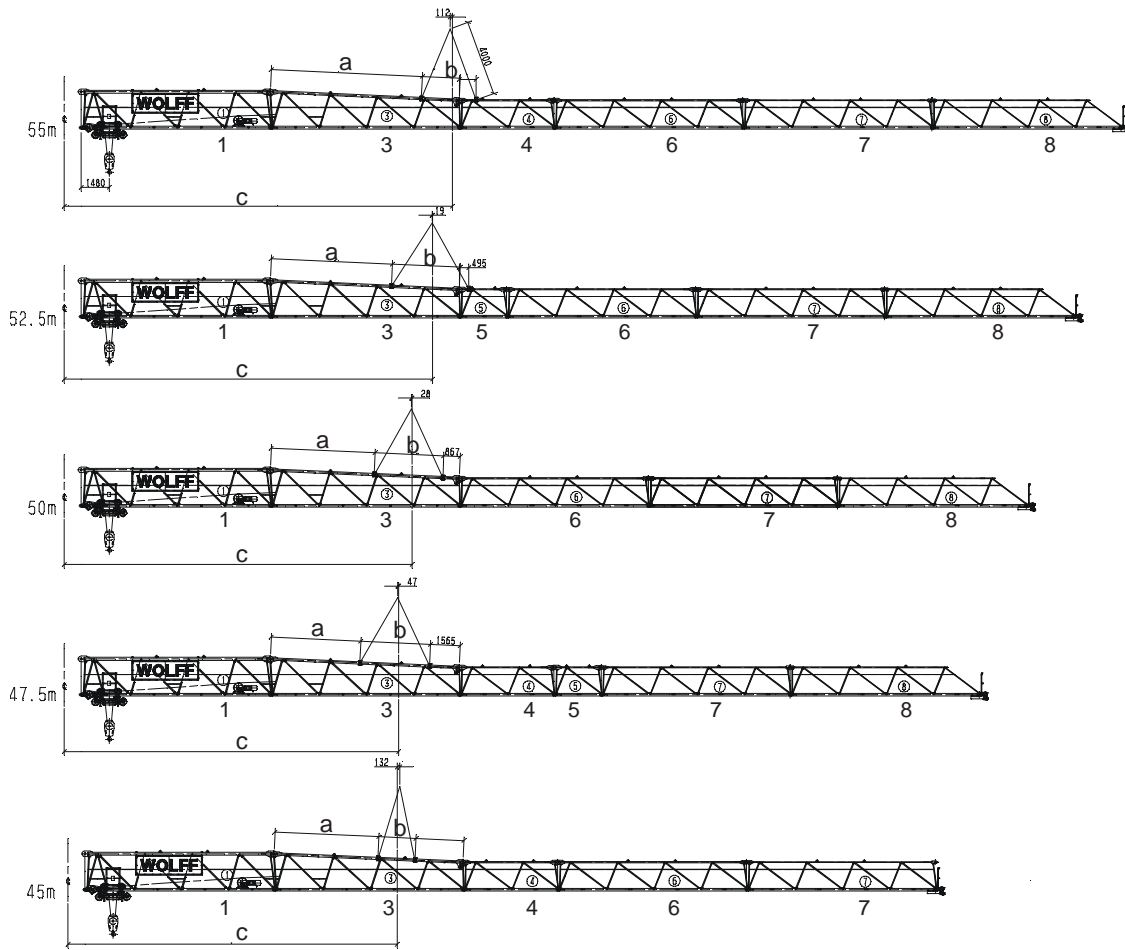

a	Dimension a		c	Dimension c	
b	Dimension b				
Jib length [m]					
Data	55	52.5	50	47.5	45
a [mm]	8003	6413	5503	4743	5503
b [mm]	2000	3590	3633	3695	1963
c [mm]	20530	19480	18400	17690	17420
Weight [kg] 5020 clear	7600	7300	6900	6900	6900

7.1.2 Trolley jib - attachment diagram 42.5 m to 32.5 m

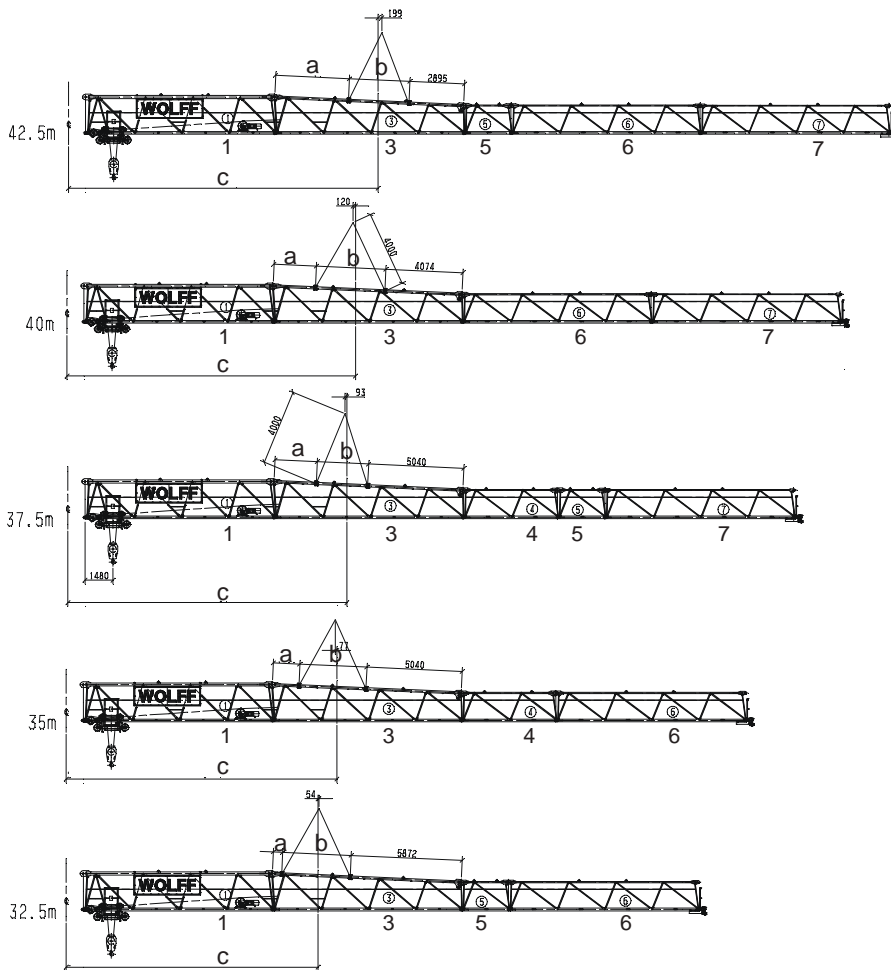

a	Dimension a	c	Dimension c
b	Dimension b		

Data	Jib length [m]				
	42.5	40	37.5	35	32.5
a [mm]	3911	2241	2241	1408	502
b [mm]	3198	3688	2723	3555	3629
c [mm]	16370	15260	14760	14320	13320
Weight [kg] 5020 clear	6600	6200	6300	6100	5900

7.1.3 Trolley jib - attachment diagram 30 m to 20 m

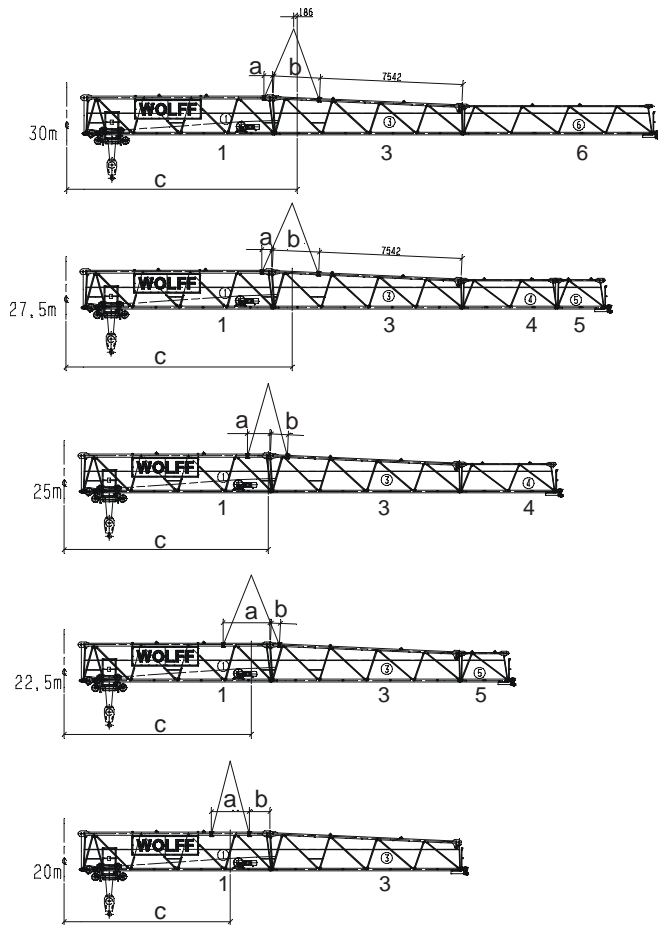

a	Dimension a	c	Dimension c
b	Dimension b		

Data	Jib length [m]				
	30	27.5	25	22.5	20
a [mm]	465	527	1192	2479	2000
b [mm]	2461	2461	912	490	1095
c [mm]	12190	11970	10790	9900	8790
Weight [kg] 5020 clear	5500	5500	5100	4800	4500

7.2 Trolley jib mounting rig



NOTICE

For information on the arrangement of the mounting rig, refer to the attachment diagram.

Two mounting rigs are required per slewing tower crane.

Elements required for each mounting rig

Quantity	Item	Dimensions	Material
1	Mounting rig		
4	Hexagonal head bolt	M16 x 240	ISO 4017-8.8 galv.
8	HSFG washer	17	EN 14399 galvanized
8	Hexagonal nut	M16	ISO 4032-8 galvanized

Mounting rig

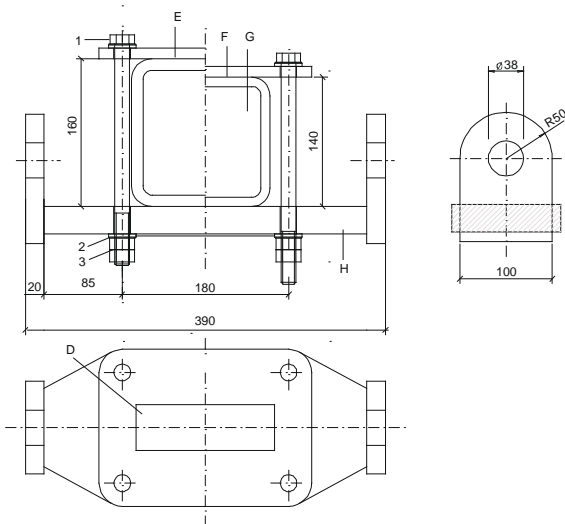



1	Hexagonal head screw	A	Mounting rig
2	HSFG washer	W	Top belt trolley jib
3	Hexagonal nut		

8 Suitable climbing frames

This section contains information on

- Outer climbing units
- Inner climbing units (KSH)

	WARNING
	<p>Climbing unit attached to the cat head bottom section Increased wind surface. The slewing tower crane may overturn.</p> <ol style="list-style-type: none">1) Lower the climbing unit down on the tower, or2) dismantle the climbing unit.

	NOTICE
	<p>The operating radius specified is measured from the tower center and is to be considered a reference value. Exact balancing can be achieved by moving the trolley with the tower elements specified in the table or a load and can be checked by moving the end stops of the tower apart without offsets.</p>

	NOTICE
	<p>The data required and the instructions for tower assemblies with inner climbing unit is available in the separate description of the inner climbing unit.</p>

DANGER! Observe the special tower combination for the inner climbing unit.

	NOTICE
	<p>Details for climbing balancing The climbing balancing details apply to the snatch block in maximum hook position.</p>

8.1 Outer climbing units

	NOTICE
	If feasible, you should preferably operate your climbing frame without balancing weight.

	NOTICE
	Tower element on the transfer carriage The data on climbing balance was specified under the assumption that a tower element is on the transfer carriage.

8.1.1 Outer climbing unit KWH 15.2

	NOTICE
	Minimum height for stationary setup:
	2 tower elements = 9.0 m tower height
	Minimum height for crawling towers:
	2 tower elements + bogie truck = approx. 13.5 m tower height

Climbing radius for balancing weights with TFS 15 tower elements

	Jib length [m]														
	55	52.5	50	47.5	45	42.5	40	37.5	35	32.5	30	27.5	25	22.5	20
no weight	25.6	41.0	36.8	-	-	-	-	-	-	-	-	-	-	-	-
TFS 15 = 1.41 t	8.7	14.3	12.7	14.8	15.9	17.1	18.8	20.0	18.7	19.1	20.3	20.7	-	-	-
Weight = 5.00 t	-	4.9	4.3	5.1	5.5	6.0	6.6	7.1	6.5	6.7	7.2	7.3	8.0	7.3	8.2

Climbing radius for balancing weights with UV 15 tower elements

	Jib length [m]														
	55	52.5	50	47.5	45	42.5	40	37.5	35	32.5	30	27.5	25	22.5	20
no weight	24.1	39.5	35.3	-	-	-	-	-	-	-	-	-	-	-	-
UV 15 = 1.73 t	6.9	11.8	10.5	12.2	13.2	14.2	15.7	16.8	15.6	16.0	17.0	17.4	18.8	17.4	-
Weight = 5.00 t	-	4.7	4.1	4.9	5.3	5.8	6.4	6.9	6.3	6.5	7.0	7.1	7.8	7.1	8.0

8.1.2 Outer climbing unit KWH 20.3 / KWH 20.3.1

	NOTICE
	Minimum height for stationary setup:
	3 tower elements = 13.5 m tower height
	Minimum height for crawling towers:
	2 tower elements + bogie truck = approx. 13.5 m tower height

Climbing radius for balancing weights with TFS 20 tower elements

	Jib length [m]														
	55	52.5	50	47.5	45	42.5	40	37.5	35	32.5	30	27.5	25	22.5	20
no weight	7.8	23.3	20.0	25.5	28.6	-	-	-	-	-	-	-	-	-	-
TFS 20 = 1.41 t	-	7.1	6.0	7.9	8.9	10.4	11.9	13.1	12.1	12.6	14.0	14.4	16.0	14.7	-
Weight = 5.00 t	-	-	-	-	-	-	4.1	4.6	4.2	4.4	5.0	5.1	5.8	5.3	6.1

Climbing radius for balancing weights with UV 20 tower elements

	Jib length [m]														
	55	52.5	50	47.5	45	42.5	40	37.5	35	32.5	30	27.5	25	22.5	20
no weight	5.4	20.9	17.6	23.2	26.3	30.6	-	-	-	-	-	-	-	-	-
UV 20 = 1.94 t	-	5.0	4.1	5.6	6.5	7.7	9.0	10.0	9.2	9.6	10.8	11.1	12.4	11.3	13.1
Weight = 5.00 t	-	-	-	-	-	-	3.8	4.3	3.9	4.1	4.7	4.8	5.5	5.0	5.8

8.1.3 Outer climbing unit KWH 20.6/ KWH 20.6.1

	NOTICE
	Minimum height for stationary setup:
	2 tower elements = 9.0 m tower height
	Minimum height for crawling towers:
	2 tower elements + bogie truck = approx. 13.5 m tower height

NOTICE! KWH 20.6.1 can only be operated with 5020.8 clear.

NOTICE! At a jib length of 55 m, climbing operations are not possible with KWH 20.6.1 and KWH 20.6

Climbing radius for balancing weights with TFS 20 tower elements

	Jib length [m]														
	55	52.5	50	47.5	45	42.5	40	37.5	35	32.5	30	27.5	25	22.5	20
no weight	-	20.2	16.9	22.4	25.5	29.8	-	-	-	-	-	-	-	-	-
TFS 20 = 1.41 t	-	6.0	4.9	6.8	7.9	9.3	10.9	12.1	11.1	11.5	13.0	13.4	15.0	13.7	15.8

Climbing radius for balancing weights with UV 20 tower elements

	Jib length [m]														
	55	52.5	50	47.5	45	42.5	40	37.5	35	32.5	30	27.5	25	22.5	20
no weight	-	17.8	14.5	20.0	23.1	27.4	-	-	-	-	-	-	-	-	-
UV 20 = 1.94 t	-	4.1	3.2	4.8	5.6	6.8	8.1	9.1	8.3	8.7	9.9	10.2	11.5	10.4	12.2

8.2 Inner climbing units

8.2.1 Inner climbing unit KSH 15

Tower combinations for slewing tower cranes with inner climbing unit.

Item			
1	UV 15.4	UV 15.4	UV 15.4
2	UV 15.4	UV 15.4	UV 15.4
3	UV 15.4	UV 15.4	UV 15.4
4	UV 15.4	UV 15.4	UV 15.4
5		UV 15.4	UV 15.4
6			UV 15.4
Inner climbing frame	KSH 15	KSH 15	KSH 15
Foundation	FUA 120	FUA 120	FUA 120
Tower height [m]	33.0	37.5	42.0
Hook height above ground [m]	34.5	39.0	43.5

Climbing radius for the balancing weights

	Jib length [m]														
	55	52.5	50	47.5	45	42.5	40	37.5	35	32.5	30	27.5	25	22.5	20
UV 15.4 = 1.75 t	26.0	30.7	28.5	30.3	31.2	31.5	32.8	-	-	-	-	-	-	-	-
Weight = 5.00 t	11.4	13.5	12.5	13.3	13.7	13.8	14.4	14.9	14.0	14.2	14.3	14.4	15.0	14.0	14.8

WOLFFKRAN

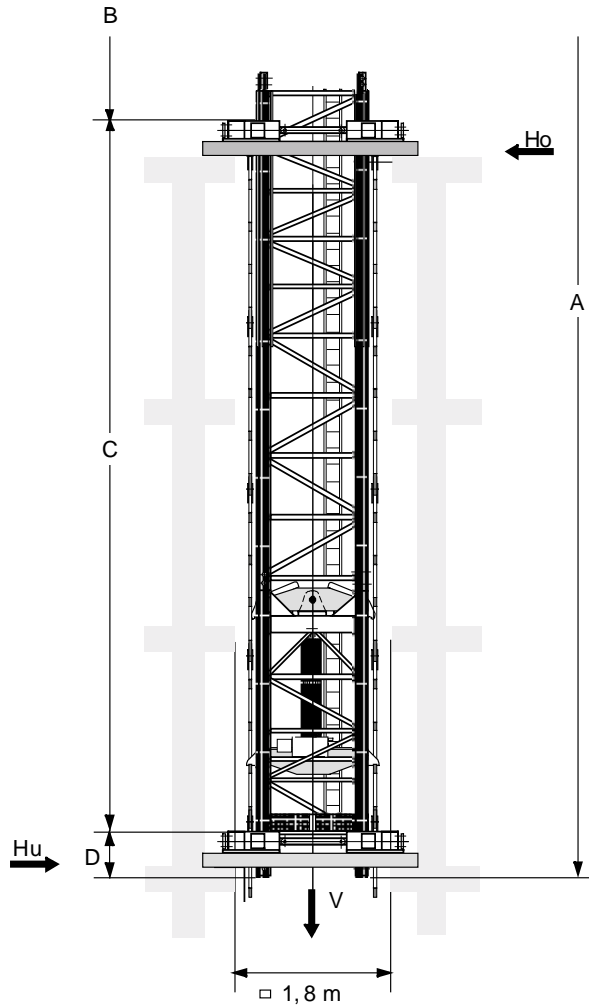

$$C_{min} = 9,0 \text{ m}$$

$$C_{max} = 14,0 \text{ m}$$

$$H_o = \frac{M}{C} + H$$

$$H_u = H_o - H$$

$$T = \frac{M_D}{2 \times b}$$

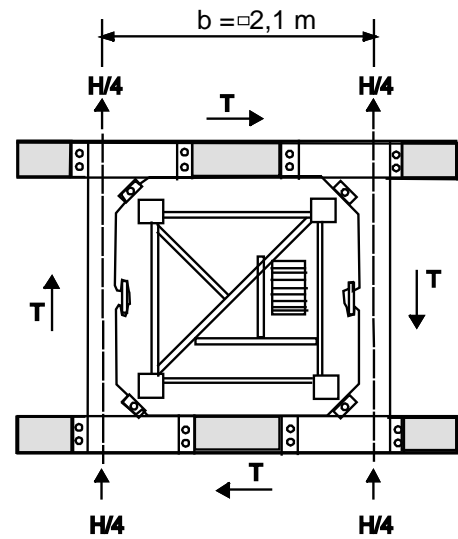

A	= Tower height	C	= Distance between guide frames
W	= A-C-D		

8.2.2 Inner climbing unit KSH 20 M

Tower combinations for tower cranes with inner climbing unit.

Item		
1	UV 20.4 LC	UV 20.4
2	UV 20.4 LC	UV 20.4 LC
3		UV 20.4 LC
Inner climbing frame	KSH 20 M	KSH 20 M
Foundation	FUA 120	FUA 120
Tower height [m]	37.5	42.0
Hook height above ground [m]	39.0	43.5

Climbing radius for the balancing weights

	Jib length [m]														
	55	52.5	50	47.5	45	42.5	40	37.5	35	32.5	30	27.5	25	22.5	20
TFS 20.4 = 1.56 t	28.1	33.2	30.8	32.7	33.8	34.0	-	-	-	-	-	-	-	-	-
UV 20.4 = 2.05 t	23.2	27.5	25.5	27.1	28.0	28.2	29.3	30.3	28.6	-	-	-	-	-	-
Weight = 5.00 t	11.4	13.5	12.5	13.3	13.7	13.8	14.4	14.9	14.0	14.2	14.3	14.4	15.0	14.0	14.8

WOLFFKRAN

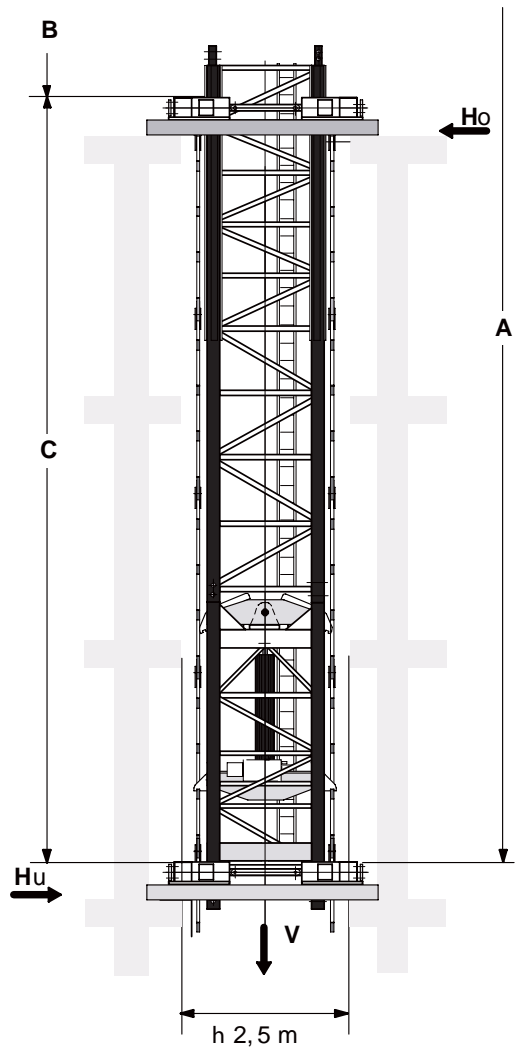

$$C_{\min} = 11,0 \text{ m}$$

$$C_{\max} = 14,0 \text{ m}$$

$$H_o = \frac{M}{C} + H$$

$$H_u = H_o - H$$

$$T = \frac{M_D}{2 \times a}$$

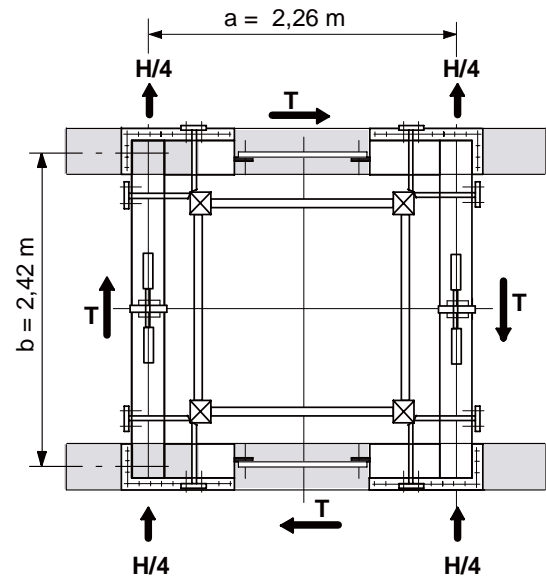

A	Tower height	C	Distance between guide frames
W	A-C-D	D	0.77 m

8.2.3 Inner climbing unit KSH 20 L

Tower combinations for tower cranes with inner climbing unit.

Item			
1	UV 20.4	UV 20.4	UV 20.4
2	UV 20.4	UV 20.4	UV 20.4
3	UV 20.4	UV 20.4	UV 20.4
4	UV 20.4	UV 20.4	UV 20.4
5	UV 20.4	UV 20.4	UV 20.4
6		UV 20.4	UV 20.4
7			UV 20.4
8			
Inner climbing frame	KSH 20 L	KSH 20 L	KSH 20 L
Foundation	FUA 120	FUA 120	FUA 120
Tower height [m]	36.5	41.0	45.5
Hook height above ground [m]	38.0	42.5	47.0

Climbing radius for the balancing weights

	Jib length [m]														
	55	52.5	50	47.5	45	42.5	40	37.5	35	32.5	30	27.5	25	22.5	20
TFS 20.4 = 1.56 t	28.1	33.2	30.8	32.7	33.8	34.0	-	-	-	-	-	-	-	-	-
UV 20.4 = 2.05 t	23.2	27.5	25.5	27.1	28.0	28.2	29.3	30.3	28.6	-	-	-	-	-	-
Weight = 5.00 t	11.4	13.5	12.5	13.3	13.7	13.8	14.4	14.9	14.0	14.2	14.3	14.4	15.0	14.0	14.8

WOLFFKRAN

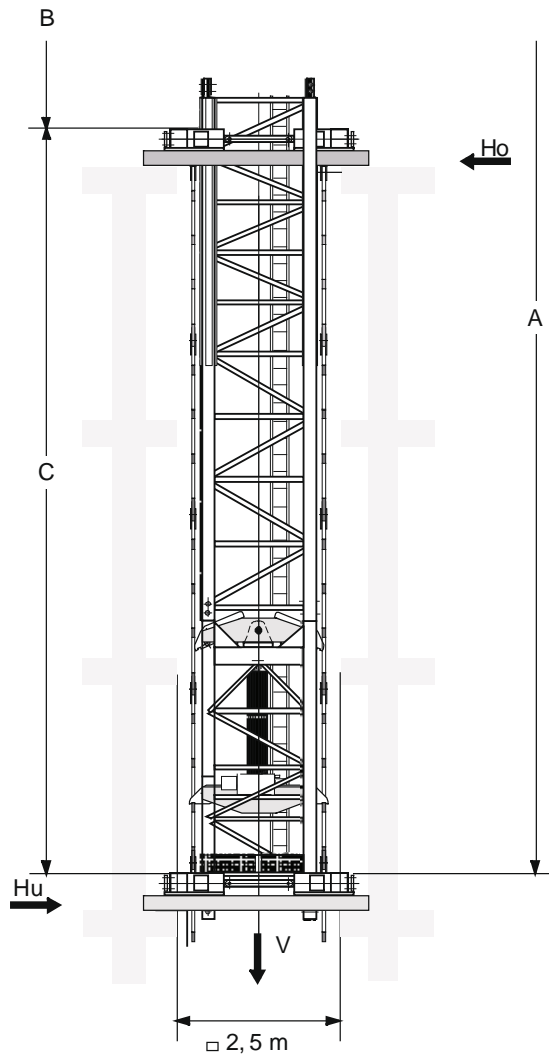

C_{min}	=	9,0 m
C_{max}	=	13,0 m
H_o	=	$\frac{M}{C} + H$
H_u	=	$H_o - H$
T	=	$\frac{M_D}{2 \times b}$

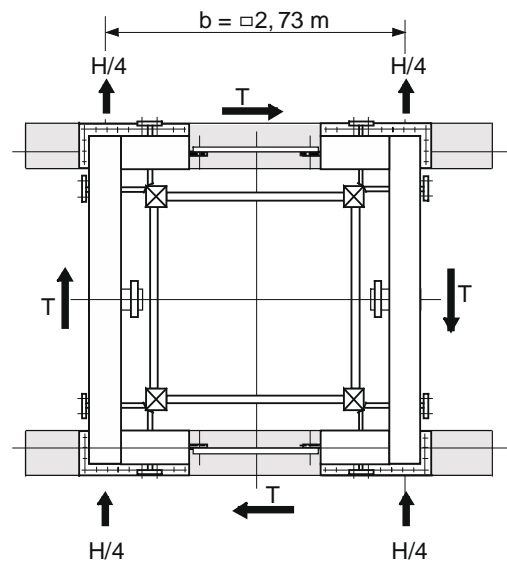

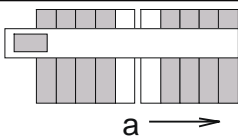
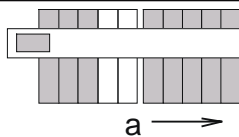
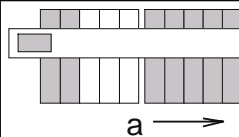
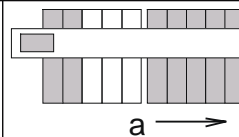
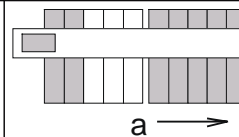
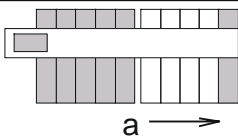
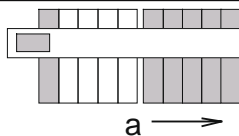
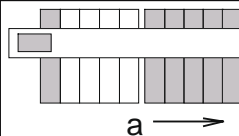
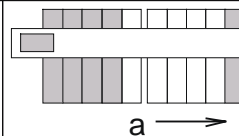
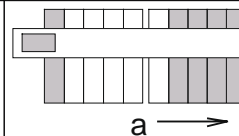
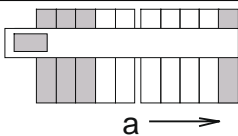
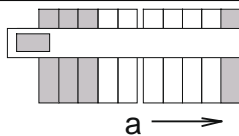
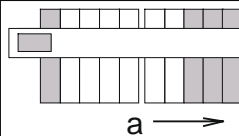
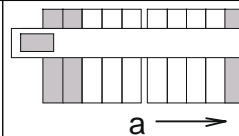
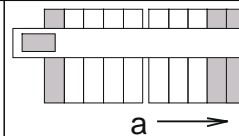

A	= Tower height	C	= Distance between guide frames
W	= A-C-D		

9 Arrangement of counterweight blocks

L = 55 m	L = 52.5 m	L = 50 m	L = 47.5 m	L = 45 m
8 x 2.05 t	8 x 2.05 t	7 x 2.05 t	7 x 2.05 t	7 x 2.05 t
				
W = 17.6 t	W = 17.6 t	W = 15.6 t	W = 15.6 t	W = 15.6 t
L = 42.5 m	L = 40 m	L = 37.5 m	L = 35 m	L = 32.5 m
6 x 2.05 t	6 x 2.05 t	6 x 2.05 t	5 x 2.05 t	5 x 2.05 t
				
W = 13.5 t	W = 13.5 t	W = 13.5 t	W = 11.5 t	W = 11.5 t
L = 30 m	L = 27.5 m	L = 25 m	L = 22.5 m	L = 20 m
4 x 2.05 t	4 x 2.05 t	4 x 2.05 t	3 x 2.05 t	3 x 2.05 t
				
W = 9.4 t	W = 9.4 t	W = 9.4 t	W = 7.4 t	W = 7.4 t

Additional permanent counterweight for all jib lengths: 1.2 t

L	Jib length [m]	a	To the tower
G	Total weight [t]		Counterweight
	No counterweight		

