

**STT113
TOWER CRANE**

II. OPERATION & SERVICE MANUAL



2007R32

Fushun Yongmao Construction Machinery Co. Ltd.

Table of contents

| | | |
|----------------------------|--|-------|
| Chapter I | Tower crane parameter and structure..... | 1B-1 |
| Chapter II | Safe rules of tower crane | 2B-1 |
| Chapter III | Operation..... | 3B-1 |
| Chapter IV | Power supply and schematic diagram..... | 4B-1 |
| Chapter V | Hoisting winch | 5B-1 |
| Chapter VI | Slewing mechanism | 6B-1 |
| Chapter VII | Trolley winch..... | 7B-1 |
| Attached: Electric diagram | | |
| Chapter VIII | Safety device | 8B-1 |
| Chapter IX | Hydraulic system | 9B-1 |
| Chapter X | Fitting and inspection rules of wire rope for hoisting machinery..... | 10B-1 |
| Chapter XI | Slewing ring | 11B-1 |
| Chapter XII | Tower crane maintenance | 12B-1 |

Chapter I Tower Crane Parameter and Structure

I. Main performance parameter and external dimensions

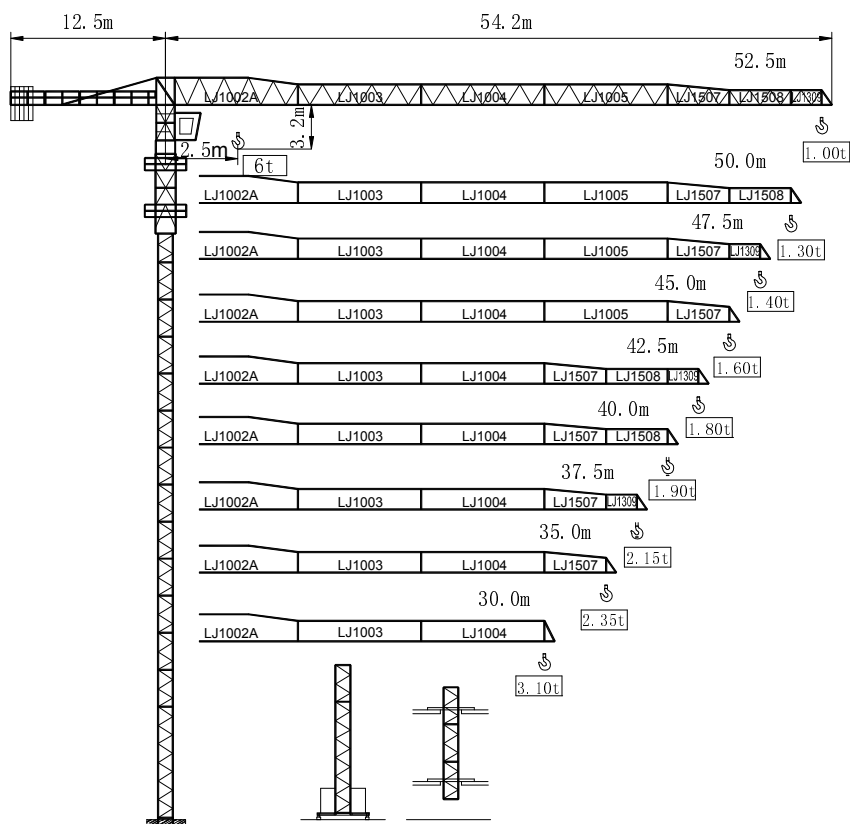

Loading capacity

Table 1—2—1

| R | Fall | R(max) m | C(max) t | 20 | 25.0 | 30.0 | 35.0 | 37.5 | 40.0 | 42.5 | 45.0 | 47.5 | 50.0 | 52.5 |
|------|------|-------------|-------------|------|------|-------------|-------------|-------------|-------------|-------------|-------------|-------------|-------------|-------------|
| 52.5 | IV | 12.76 | 6.00 | 3.52 | 2.67 | 2.12 | 1.73 | 1.57 | 1.43 | 1.31 | 1.21 | 1.11 | 1.03 | 0.95 |
| | II | 23.05 | 3.00 | 3.00 | 2.72 | 2.16 | 1.77 | 1.62 | 1.48 | 1.36 | 1.26 | 1.16 | 1.08 | 1.00 |
| 50.0 | IV | 14.43 | 6.00 | 4.09 | 3.13 | 2.49 | 2.05 | 1.87 | 1.71 | 1.58 | 1.46 | 1.35 | 1.25 | |
| | II | 26.18 | 3.00 | 3.00 | 3.00 | 2.54 | 2.09 | 1.92 | 1.76 | 1.63 | 1.50 | 1.40 | 1.30 | |
| 47.5 | IV | 14.45 | 6.00 | 4.10 | 3.13 | 2.50 | 2.05 | 1.87 | 1.72 | 1.58 | 1.46 | 1.35 | | |
| | II | 26.22 | 3.00 | 3.00 | 3.00 | 2.55 | 2.10 | 1.92 | 1.77 | 1.63 | 1.51 | 1.40 | | |
| 45.0 | IV | 15.06 | 6.00 | 4.31 | 3.30 | 2.64 | 2.17 | 1.98 | 1.82 | 1.68 | 1.55 | | | |
| | II | 27.38 | 3.00 | 3.00 | 3.00 | 2.68 | 2.22 | 2.03 | 1.87 | 1.73 | 1.60 | | | |
| 42.5 | IV | 15.53 | 6.00 | 4.47 | 3.43 | 2.74 | 2.26 | 2.07 | 1.90 | 1.75 | | | | |
| | II | 28.25 | 3.00 | 3.00 | 3.00 | 2.79 | 2.31 | 2.11 | 1.95 | 1.80 | | | | |
| 40.0 | IV | 15.24 | 6.00 | 4.37 | 3.35 | 2.68 | 2.20 | 2.01 | 1.85 | | | | | |
| | II | 27.72 | 3.00 | 3.00 | 3.00 | 2.73 | 2.25 | 2.06 | 1.90 | | | | | |
| 37.5 | IV | 15.72 | 6.00 | 4.53 | 3.48 | 2.79 | 2.29 | 2.10 | | | | | | |
| | II | 28.62 | 3.00 | 3.00 | 3.00 | 2.83 | 2.34 | 2.15 | | | | | | |
| 35.0 | IV | 15.75 | 6.00 | 4.54 | 3.49 | 2.79 | 2.30 | | | | | | | |
| | II | 28.67 | 3.00 | 3.00 | 3.00 | 2.84 | 2.35 | | | | | | | |
| 30.0 | IV | 17.12 | 6.00 | 5.01 | 3.86 | 3.10 | | | | | | | | |
| | II | 30.00 | 3.00 | 3.00 | 3.00 | 3.00 | | | | | | | | |

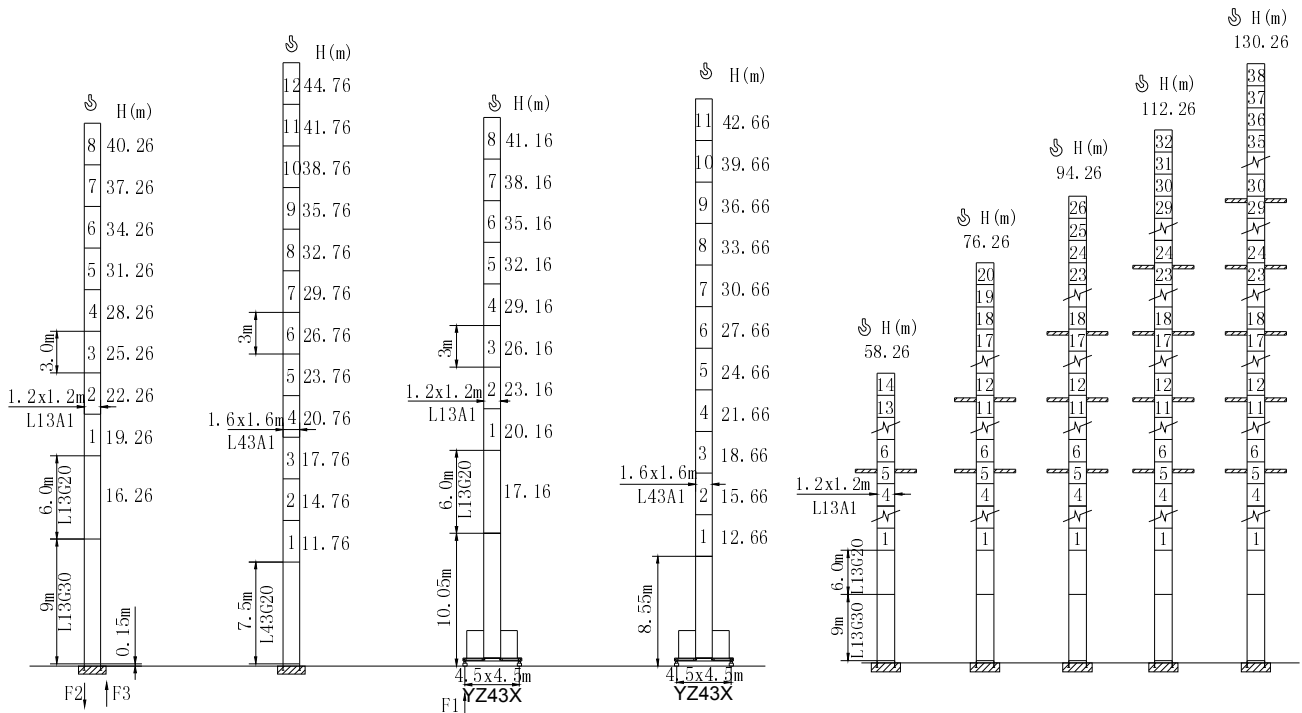

Table 1-2-2

| Type | Stationary type | | Traveling type | |
|-------------|-----------------|----------------|----------------|----------------|
| | In service | Out of service | In service | Out of service |
| F1 | | | 65t | 46t |
| F2 | 98t | 112t | | |
| F3 | 70t | 135t | | |
| Dead weight | 52t | | 64t | |

STT113 main performance parameter of tower crane mechanism

Table 1-2-3

| Items | Mechanism | Speed / Hoist weight | | | | Rope capacity | Motor Kw |
|-----------------------|-----------|----------------------|-----|---------------|-----|----------------|-----------|
| | | m/min | t | m/min | t | | |
| Hoisting | 24PQC15 | $\frac{v}{g}$ | | $\frac{v}{g}$ | | 400m >400m* | 24/24/5.5 |
| | | ○—8.5 | 3.0 | ○—4.2 | 6.0 | | |
| | | ○—40 | 3.0 | ○—20 | 6.0 | | |
| | | ○—80 | 1.5 | ○—40 | 3.0 | | |
| Trolleying | DTC55 | 0→57 m/min | | | | 55 N.m | |
| Slewing | RTC95 | 0-0.7rpm | | | | 95 N.m | |
| Traveling | RT | 12.5-25 m/min | | | | 2x1.7/3.4 | |

* Consult us

Chapter II Safe Rules of Tower Crane

I. manual of safe rules 2B-2

I. manual of safe rules

1. The regulation of correct used

- (1) It is forbidden to use the tower crane which has not pass the performance test;
- (2) According to the technique regulation and method of use, the crane must be used in its good condition. Pay more attention to the safety to prevent the dangerous! Eliminate all kinds of malfunctions in time which may cause the safety accident;
- (3) Operate the tower crane in specified scope of temperature: (-20°C--+40°C);
- (4) Operate the crane in specified limit of wind speed (the max. wind speed for operating is 20m/s, the max. wind speed out of service is 50m/s);
- (5) Observe the regulation in operation manual and regulation related to service and maintenance.

2. Safety measures

- (1) The operator should read the operation rules before operating the tower crane;
- (2) The operator should always remember every safety measure and recognize the hazard, meanwhile, the operation rules should be visible;
- (3) It's forbidden for the operator to be with long hair, wearing robe or wearing jewelry;
- (4) Often read the warning board about safety and preventing from hazard;
- (5) If the crane is in abnormal condition, stop operation immediately and report it to the interested person;
- (6) It is forbidden to change or add any parts of the crane, unless the tower crane manufacturer permitted;
- (7) Service, lubricate and debug the crane according to the cycle specified in operation manual;
- (8) The crane operator should know the position of fire proofing equipment, and grasp the method of using it.

3. Personnel selecting and their qualifications

- (1) The tower crane must be operated by qualified person;
- (2) The crane operator must be trained. There must be a specific regulation about the ability of driver, erector, maintenance and service person;
- (3) Crane operators should clarify their responsibility, and make them know that they should refuse all the order which act against the safety;
- (4) The experienced personnel must supervise at jib site when the tower crane is operated by trainees or learners.
- (5) The installing, debug and maintenance of electric equipment must be operated by competent electrician.
- (6) The debug and maintenance for each mechanism must be operated by professional;
- (7) The installing, debug and maintenance of hydraulic device must be operated by experienced professional.

4. The safety rules during working stage

- (1) Every time before starting up:
 - a). Give audience to the order of job site supervisor;
 - b). Switch on;
 - c). Remove cushion block, loosen the rail clamping device and other fixing device (wind speed $\leq 13\text{m/s}$);
 - d). Check that is there any obstacle on the track;
 - e). Cancel the jib weather vane condition;
 - f). Check that are all the protective device and safety device in normal condition.

(2) In service

- a). The driver should operate the crane in the cabin;
- b). Test the motion of each mechanism with no load and low speed, meanwhile, check that whether the brake is sensitive before lifting load;
- c). It is forbidden to use any operating mode which can threaten the tower crane safety;
- d). Before traveling, drive the jib to the center line of the track;
- e). It is forbidden to pass load over the person when the crane is in service;
- f). It requires someone to guide, when the load is out of the sight of the driver;
- g). It is forbidden to sling overweight load out of the specified radius;
- h). It is forbidden to sling heavy load when the load has not been hang firmly;
- i). It is forbidden to canting pull the load;
- j). It is forbidden to sling the load which has fixed to the ground;
- k). It is forbidden to stop normal motion by emergency stop button; it only can be used in exceptional case which may threaten the safety;
- l). It is forbidden to use limiter and brake as an normal stop device;
- m). It is forbidden to short-circuit, change and adjust the safety device, or obstruct its normal operation;
- n). When the max. wind speed is less than 20m/s, windward surface of the load should be lower than $1\text{m}^2/\text{t}$. Stop working if the wind speed reaches to 20m/s;
- o). Make sure that there is no obstacle enters into jib slewing area after the tower crane traveling;
- p). If the crane operation is in bad condition, stop immediately and sent somebody to repair;
- q). Make sure that there is enough distance between the tower crane and air electric wire;

(3) After one day's work:

- a). Lift the hook below the limit point, meanwhile, it is forbidden to leave any load on the hook;
- b). Drive the trolley close to the mast;
- c). Starting the weather vane;
- d). Grip the clamp rail on the track;
- e). Cut off the power supply and locked.

5. Maintenance and fault clearance during the tower crane operation

- (1) Debug, maintenance and check-up each part of the crane according to the method and cycle specified in operation manual; and replace some parts and devices according to the regulation;
- (2) If it needs to service and maintenance the tower crane with power outage, adopt necessary measures to prevent false starting of the crane. First, lock the power supply panel, and take off the key. Second, hang warning plate on the panel;
- (3) If it needs to dismantle some safety devices during service and maintenance, after this, it should be assembled and readjusted.

6. Instruction for special dangerous

- (1) When operating tower crane near the air line, there should be enough distance between the tower crane and air line.
 - a). Once the tower crane connected with the air line, the drive should stay in the cab, to prevent from getting an electric shock;
 - b). Drive the crane out of dangerous zone at once;
 - c). Notify the person around don't close to the crane;
 - d). Cut off the power supply which connected with the air line;
 - e). Don't leave the tower crane unless you can confirm that the electric wire has been cut off

- (2) Maintenance of the electrical equipment only can be carried out by qualified electrician or trainee which is supervised by a qualified electrician according to the electrical rules.
- a). The tower crane must be cut off the electricity during maintenance and repair, meanwhile, set up a warning plate of “manned operation, prohibit switch on” on the obvious position of power supply panel, then earth or short circuit the power line (after this, do please dismantle the earthing and short circuit line);
 - b). The electrical equipment of tower crane should be checked periodically. If discover some hidden danger, such as connection loosen, electrical wire earthing, component breakage, etc, it must be eliminated in time;
 - c). If it must carry out live-wire work, there should be someone to monitor, so that the main power supply can be cut off in emergency situation.

7. Hydraulic system

- a). Only the professional or experienced person can operate the hydraulic system;
- b). Periodic check every kind of conduct pipe, flexible pipe and joint, so that check up the oil leak and external malfunction, if so, eliminate that immediate (oil leak may cause damage and fire);
- c). Release the component pressure according to the relevant regulations before repairing.
- d). Install the hydraulic pipe line correctly. Do not connect the high and low pressure interfaces in reverse. Meanwhile, the joint length and quality of the flexible pipe should meet the requirement;
- e). Hold the oil quantity and quality in the oil box. Check the hydraulic oil quality periodically, if the oil has already deteriorated, it must be replaced at once which can ensure the pump station work normally.

Chapter III Operation

| | |
|--|-------|
| I. General rules | 3B-2 |
| II. Operation highlight | 3B-3 |
| III. Operation instruction | 3B-4 |
| IV. Precautions during operation | 3B-7 |
| 1. Each time before operation | 3B-7 |
| 2. During operation | 3B-7 |
| 3. Each time after operation | 3B-8 |
| 4. Periodical inspection item | 3B-9 |
| V. Operation | 3B-14 |
| 1. Control panel layout and operating method | 3B-14 |
| 2. Precautions during operation | 3B-17 |
| 3. Operating method for weather vane effect | 3B-18 |

Important declaration:

A thorough debug must be made upon finishing the installation and erection of the tower crane. The tower crane can only be put into service when it is approved by local safety authorities with the issuance of license.

I. General rules

Tower crane driver must be the qualified professional who has trained by authoritative board of labor or specified units and passed the exam.

The driver must operate, service and maintain the crane correctly. It is important for reducing failure, improving device availability, avoiding loss of working time and prolonging service life of equipment.

Incorrect operating will result in damage of all electric motor, reducer, drum, brake and wire rope, even the integral steel construction. What is more, it may cause serious mechanical accident, and result in personnel loss.

II. Operation highlight

- a) Control panel is finishing equipment. It must be careful when operating it.
- b) The control lever must be operated slowly when starting or stopping.
- c) Change shift one by one, it is forbidden to get over shift.
- d) It is forbidden to disobey sequential operation when stopping some action.
- e) The control lever should turn to zero position gradually when actuating device making reverse movement. Operate until the mechanism completely stopped.
- f) It is forbidden to operate the crane which safety device has a failure, unsoundness or inaccurate, furthermore it is forbidden to pick off or sealed the safety device.
- g) Discovery the stoppages should stop and check immediately forbid to be continue. Once discover some failure, it must be stopped and checked immediately. It is forbidden to operate the crane with failure.
- h) The driver is entitled to refuse the command which against safety rules.
- i) The driver must master the moment curve, the max. load, the min. load (at the jib end) and the load under hook in random radius.

III. Operation instruction

(1) Starting

- a) Check the tower crane before everyday starting according to the instruction regulation. If there is any problem, report it and it is not allowed to start any more.
- b) Switch on the main power supply and press the start button.
- c) Test the working order of all mechanisms with low speed gear in light condition and check the limit device of all mechanisms.
- d) Check that whether all safety devices are integrated and acting reliable.
- e) Before lifting load, check the sensitivity and reliability of the brake.

(2) Operating the hoisting winch

- a) Confirm the lifting load radius according to the moment curve (or table).
- b) Estimate the weight of lifting load
 - Lift the load 1m high slowly in small radius.
 - Move the load forward slowly by changing radius of trolley with low speed.
 - Stop forward movement when moving to the position of moment limiter.
 - Confirm the radius of trolley stopping.
 - Estimate the weight of load according to moment characteristic diagram (table) and radius.
- c) Use the Min. lifting speed before the wire rope tightened up.
- d) Use the Min. lowering speed when lowering load.
- e) Use the medium speed when start lifting (after load taking off the ground) or be over lifting.
- f) If the height is allowable in normal lifting, use the rated speed of motor instead of medium speed.

- g) The speed was selected by the weight of load. Heavy load selected low speed (PV) and light load selected high speed (GV).
- h) Stop moving before operating the stroke limiter.
- i) Don't put the hook on ground.
- j) Loosen the wire rope slowly to avoid rope winding when placing load.

(3) Operating the slewing mechanism

- a) Select the slewing speed according to the shift to be reached.
- b) Every time use the max. speed as long as the angle allowed.
- c) If the slewing mechanism suddenly changes its speed, it may cause the mast twisting and jib swing. So acceleration and deceleration operation should be done gradually.
- d) It is forbidden to stop the jib by slewing brake. It should decelerate first, and then release the control lever, so that the brake can brake in minor slewing speed.
- e) The slewing brake can only be used in windy condition, it can keep jib in its position.
- f) When slewing the jib, it is recommended to operate the lifting movement and lowering movement at the same time to avoid distorting of the wire rope and it is convenient for the rope swivel to work.
- g) Stop the slewing movement before slewing limiter start to work.

(4) Operating the trolley winch

- a) The trolley speed is selected by the distance of the trolley.
- b) It must accelerate or decelerate gradually to avoid swing when suddenly changing the shift of trolley operation.
- c) Stop the trolley movement before operating the trolley limiter.

(5) Operating the traveling mechanism

- a) The traveling speed is selected by the distance of traveling.
- b) In order to ensure the tower crane safety, when it traveling in the track, the trolley must be at the jib foot; if operating in the track curve, beside keep the trolley in the jib foot, it must travel with low speed. Meanwhile, it is forbidden to keep the jib facing to the inside of curve track.
- c) Before traveling to the end of the track, the tower crane operation must be stopped.
- d) There are two brakes in the traveling motor, one of them used for buffering and decelerating, the other used for stopping the crane movement which via 6-8 seconds time delay after powering off automatically braked. After the control lever return to zero, the crane can still run a few meters, so this operation should be done advanced.
- e) Attention during traveling the crane:
 - Warn people to leave the dangerous areas by hailer;
 - Observe that if there are some obstacles on the track;
 - It is forbidden to make the cable pileup or pull it too tight.
- f) When traveling, the jib must be in the centerline of the track.

IV. Precautions during operation

The working environmental temperature of tower crane is: $-20^{\circ}\text{C}\sim+40^{\circ}\text{C}$, the max. working wind speed is 20m/s and working grade is A4.

1. Each time before operation

- a). Make sure that the power supply, cable and switches are in perfect condition.
- b). Make sure that each pin, bolt and split pin are in normal condition, restrict the jib slewing freely (release the weather vane effect).
- c). Make sure that the counter-jib ballast and base ballast are fixed firmly.
- d). Check the hoisting and trolleying wire rope.
- e). Check the lubricating of hoisting reducer and slewing ring.
- f). Switch on the power supply.
- g). Test all mechanisms with no load and check each mechanism, brake and limiter, if necessary, readjusted it.
- h). If the working height of tower crane is beyond 50m, an anemoscope must be installed. If the wind speed exceeds 20m/s, it can sent audible and visual alarm, then, the tower crane must stop working.

2. During operation

- a). Never lift load beyond the permitted radius.
- b). Never pull load in an oblique direction.
- c). When entering into the cabin, check that whether the extinguisher, instruction plate and warning plate are in place.
- d). Check that whether the hailer is in perfect condition.
- e). Never lift load or other components which fixed on the ground.

 **Pay special attention: if hear some abnormal noise, stop operating the tower crane immediately, and inform it to the site supervisor; if the wind speed reaches to 20m/s, and sent audible and visual alarm, it must stop working; if the load is out of the sight of the driver, there must be someone as a guide; never cancel any safety device or adjust at random without authorization.**

3. Each time after operation

- a). Lift the hook to the top end.
- b). Drive the trolley to the jib foot, start the weather vane and brake device, to make the jib slewing freely (weather vane effect). If power off, manual operate this device. For traveling type tower crane, anchor the crane by 4 rail clamping devices.

NOTE: The weather vane effect, that is to say, above the upper slewing can slew freely, it can reduce the windward area automatically. Thus the crane driver must start the weather vane after he is off duty.

- c). Turn off the main power supply switch and take the measures against rain.
- d). Depress the emergency button, and cut off the power supply.

4. Periodical inspection item

1). Electricity

| Inspection item | Cycle | |
|---|---------------------|--------------|
| | After each erection | Half a month |
| Check the max. supply voltage of tower crane | | √ |
| Check that whether the connection of earth wire is in good condition | √ | √ |
| Check the connecting condition between tracks connection and between tracks and earth conductor | | √ |
| Check the earth resistance of tower crane | | √ |
| Check the insulation resistance of electric equipment | | √ |
| Check the motion of relay in each circuit, which can protect the tower crane safety | | √ |
| Check the insulation resistance of motor | | √ |
| Check the contact condition of switch contact in circuit | | √ |
| Check that whether the connecting terminal in each electrical panel and resistance box (including the inner binding screw and nut) is tightened up. | √ | √ |
| Ensure that every electrical component is in good condition, and connecting wire for them has already been tightened up | √ | √ |

2). Machinery

| Inspection item | | Cycle | | |
|------------------|--|---------------------|--------------|---|
| | | After each erection | Half a month | |
| Metal structure | Mast verticality and levelness | √ | √ | |
| | Visual inspection of gear ring bolt | | √ | |
| | Tighten up of slewing gear ring bolt | √ | √ | |
| | Visual inspection the fishplate connection on standard mast, jib, counter jib and fixing plate on base plate, including pin, split pin and bolt. | √ | √ | |
| | Detect the crack of section steel and check the weld joint | √ | √ | |
| Mechanical parts | Adjust and check the brake with max. load | Hoisting winch | | √ |
| | | Slewing mechanism | | √ |
| | | Trolleying winch | | √ |
| | | Traveling mechanism | | √ |
| | Check the worn out of the wearing plate | Hoisting winch | √ | √ |
| | | Slewing mechanism | √ | √ |
| | | Trolleying winch | √ | √ |
| | | Traveling mechanism | √ | √ |
| | Check the oil level of reducer | Hoisting winch | √ | √ |
| | | Slewing mechanism | √ | √ |
| | | Trolleying winch | √ | √ |

| | | | | |
|--------|---|-----------------------|---|---|
| | | Traveling mechanism | √ | √ |
| | | Cable drum | √ | √ |
| | | Hydraulic pushing bar | √ | √ |
| Others | Check the hook, hook pin and clamping plate | | √ | √ |
| | Adjust the tensile force of trolley wire rope | | | √ |
| | Check the wire rope and joint | | √ | √ |
| | Check that whether the swing pulley is in perfect condition | | | √ |
| | check that whether the prevent twist hook at fixing point of hook end is in perfect condition | | √ | √ |
| | Check the automatic locking device in 2/4 fall or double trolley locking device | | √ | √ |

3). Safety device

| Inspection item | Cycle | | | |
|----------------------------|----------------------|---------------------|---------------------|---------|
| | Before everyday work | After changing fall | after each erection | A month |
| Load limiter | √ | √ | √ | √ |
| Moment limiter | √ | √ | √ | √ |
| Hoisting limiter | √ | √ | √ | √ |
| Slewing limiter | √ | √ | √ | √ |
| Trolleying limiter | √ | √ | √ | √ |
| Traveling limiter | √ | √ | √ | √ |
| Prevent rope broken device | √ | √ | √ | √ |
| Prevent pin broken device | √ | √ | √ | √ |

4). Lubrication

| Inspection item | | Cycle | |
|----------------------|---|---------------------|---------|
| | | After each erection | A month |
| Hoisting winch | guide pulley of hoisting wire rope | √ | √ |
| | bearing or axle box of hoisting drum | | √ |
| | lubricate the grooved clutch gear | √ | √ |
| | ball thrust bearing of prevent twist device for hoisting hook | √ | √ |
| | hoisting wire rope | √ | √ |
| | the prevent twist device of wire rope for jib end | √ | √ |
| Slewing mechanism | slewing ring | | √ |
| | external gear ring | √ | √ |
| Trolleying winch | bearing of drum | | √ |
| | trolley guide pulley | | √ |
| | wire rope | | √ |
| | The tensioner or tension spring of the wire rope | | √ |
| | hook assembly | | √ |
| Traveling mechanism | gear ring on driving bogie wheel | | √ |
| | roller support of driven bogie and motor | | √ |
| | ball gear ring for track curve device | | √ |
| Cable drum | bearing of drum | | √ |
| Safety device | pin, spring, pinion, prevent rope broken device | | √ |
| hinge of pivot joint | cabin door, turned-door | | √ |
| track | wheel rim side of the bogie | | √ |

V. Operation

1. Control panel layout and operating method

The cabin equipped with electrical control panel (HF) and seat.

There are left control panel and right control panel on both side of the seat (they are also called joystick).

There is a control lever in the center of the joystick. (see fig. 3-2-1, layout of control panel and fig. 3-2-2, schematic diagram of lever operating)

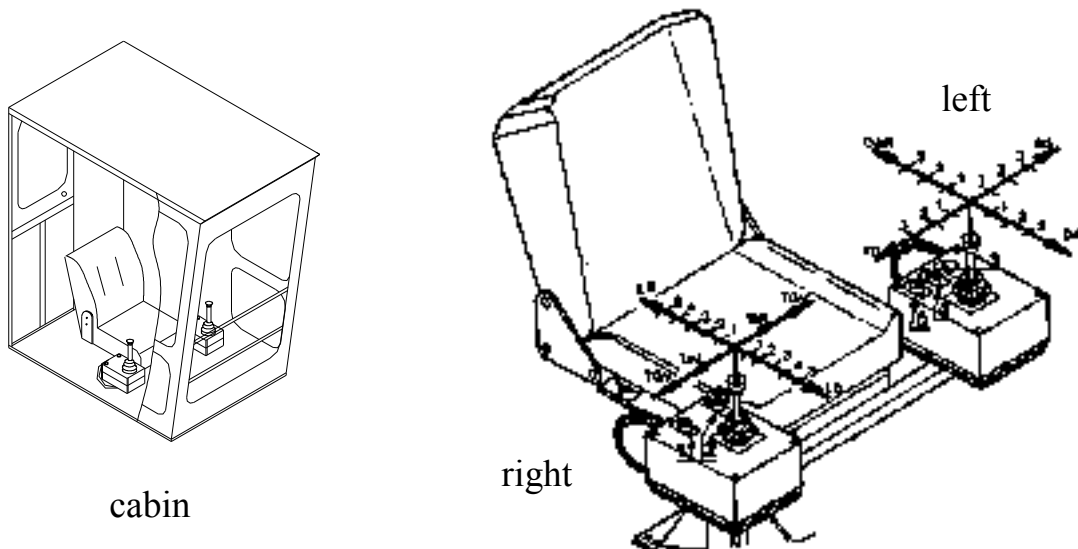

- | | | | |
|-----|-------------------------------------|-----|------------------------|
| 4 | : Parallel connection button | 5 | : Slewing brake button |
| 2 | : Power off (emergency stop) button | 3 | : Power light |
| RG | : Slewing to the left | RD | : Slewing to the right |
| DAR | : Trolley in | LD | : Lowering |
| LH | : Hoisting | DAV | : Trolley out |
| 1 | : Power supply and hailer button | TAV | : Traveling forwards |
| TAR | : Traveling backwards | | |

See fig. 3-2-1

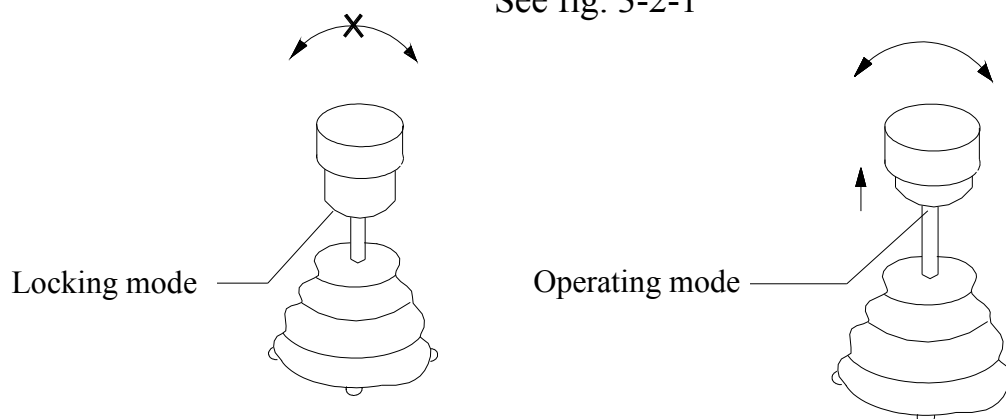

See fig. 3-2-2

ON THE LEFT CONTROL PANEL:

1). Parallel connection button SH, Graphical symbol , with functions as follows:

The button is used in the special case such as telescoping, changing fall, and so on. When move the trolley to the jib foot or raise the hook to limited position, the limited switch cut off. Press the button SH so as to continue moving the trolley to the jib root of the crane tower or making the hoist hook to a highest position until finishing the aforementioned job.

2) Slewing brake locking button XRFS, Graphical symbol , with functions as follows:

In the windy working circumstance and the speed of the wind is under 20m/s, it's necessary to hoist a load in fixed point. As the button was pressed, apply the slewing brake, which made jib fixed in place well and truly. But the premise is to stop the jib absolutely by button XRFS so as to prevent the mast tower from distortion. In the left joystick, the trolleying and slewing are operating at the same time. The control lever can switch in various directions. The trolley moves ahead **DVA** as push the lever ahead, in reverse, **DAR**. the jib slew to the left **RG** as push the lever towards left **RD**. In reverse. The lever can be pushed at random towards left or right without limit of shift. The bigger the turning angle of the lever is, the faster the speed of slewing will be. The lever can also pushed in oblique direction (to be controlled in the form of *) which drive both the trolleying and slewing operate in 2 direction at the same time.

There are locking mechanism and zero protective devices for preventing the lever from unconscious movements, which is likely to run mechanisms and result in accidents. The power supply cannot be started if the lever is not in neutral (zero) position. Take hold of the lever as shown in figure and lift locking pin up with finger, then push the lever. Before raise locking pin, it was strictly forbidden to push the lever lest parts was destroyed.

The levers on both the left control panel and the right control panel have the function of auto-reset (returning zero).

THE RIGHT CONTROL PANEL IS EQUIPPED WITH:

Power supply button (also horn button,) symbol ; warning light VOI and break button (emergency button) O. To begin with, turn the emergency button to the right till it was sprung out. Then press the power supply start button. The power supply of the tower crane was started (main contactor P of electrical control panel A start work) while the horn hooting and warning light shining. When press the break button (the emergency button) O, the power supply is turned off (main contactor P of electrical control panel A is released). The break button cannot reset (turn back) automatically. If required, turn it to the right until it springs up by itself. Press the button to cut off current when the crane is out of service or to meet the emergent requirement such as the contactor attaching mechanism is out of control or other emergency requiring current break.

As shown on the panel, the lever can be pushed in accordance with “十” instead of “米”, that is the lever can not be pushed in oblique direction. Push the lever forward to lower the hook.

(When the lever is pushed to the left or to the right (TAV, TAR), the travelling control of the crane is effected. But for the anchorage or climbing crane, there is no such kind of control lever installed. And no control circuit is set on the panel.

2. Precautions during operation

- 1) Observe the safety operation regulations strictly during the operation. The operation which might influence the safety of the crane is absolutely forbidden. For example, raise a load buried in the ground; slings (rope clamps) are not in line with relative requirement or is damaged; the load is not bundled or colligated firmly; raise a load in oblique direction or operating after drinking; and so on.
- 2) During all mechanisms operation, it was forbidden to use **lower shift** for a long time (**not exceed 10 seconds according to the regulation**), the shifts should be increased or reduced gradually, the time between two shifts should **not less than 1~1.5 seconds**. During lifting operation switch frequently between shift 4 and shift 5 is not permitted lest the part will be destroyed. It is important that nurture good operating habit. When move the trolley, do your best to switch from shift 1 to shift 2 then shift 3 and in the slewing operation the control of the lever is required to be handled harmoniously.

In any case: It is absolutely forbidden to operate in reverse direction (make return) suddenly or to press brake button forcibly during the running of the jib.

- 3) Set the tower crane in the state of weather vane whenever this shift's operation is finished.
- 4) During the operation, provided that the crane falls into the trouble, please call on service man or the mender in time. It is forbidden to operate the crane with malfunction. **In any case, for all kinds of safety devices (hoist moment limiter SLMO, trolley moment limiter SDMO, trolley reducer RDMO, overload limiter SLCHPV, hoist speed limiter SLCHGV), it is absolutely forbidden to modify their adjustments, which is adjusted well and truly during their initial installation and calibration.**
- 5) **Lubricate** your crane during operation in accordance with relevant regulations (see Chapter XII Tower crane maintenance). Pay special attention to the lubrication and worn state of the steel wire ropes (see Chapter X Wire rope installing and testing rules for hoisting machinery).

3. Operating method for weather vane effect

- 1) When the crane is out of service, press the button for 1S~2S, which situate in the side of electrical control panel **HF** (inside the operators cabin), the indicator lamp of weather vane lights up.
- 2) Cut off the current of right panel by means of the break button O. At this time, the slewing brake is unlocked (in released state). At last, cut off the main power supply of the crane.
- 3) Unlock the slewing brake manually (in release state) (see chapter 6 slewing mechanism).

Chapter IV Power supply and schematic diagram

I. Power supply of the tower crane

1. Power supply

Install the electrical equipment of tower crane according to the national standard requirement. ST series tower crane meet the relevant regulations in design and manufacture, the management regulation of power use in job site and the requirements of TN-S three-phase five-wire system or TT three-phase four-phase system power supply. The job site power supply must meet the national construction department requirements, the power use requirement “third class distribution and two class protection”. The following system diagram for your reference:

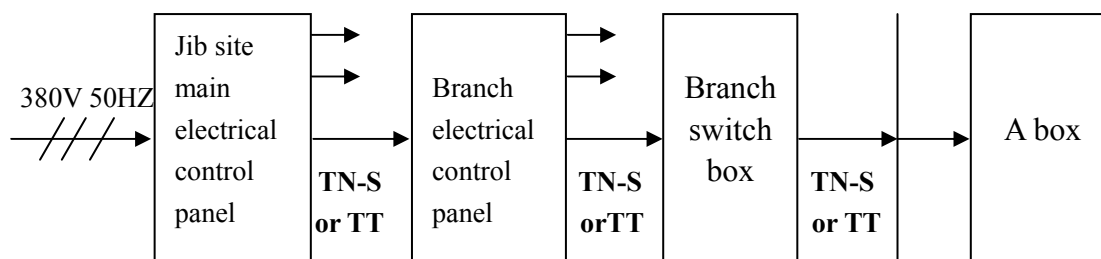

Note:

- ① Both the branch electrical control panel and branch switch box are equipped with air switches and leakage protector.
- ② The operating parameter of leakage protector in branch switch box is: **270mA, 0.1S**.
- ③ The user can select the installation method of TN-S or TT according to the local supply network administrative regulations.
- ④ All the devices before A box (including cable) should be prepared by user.

Connection mode of power supply entering into A box

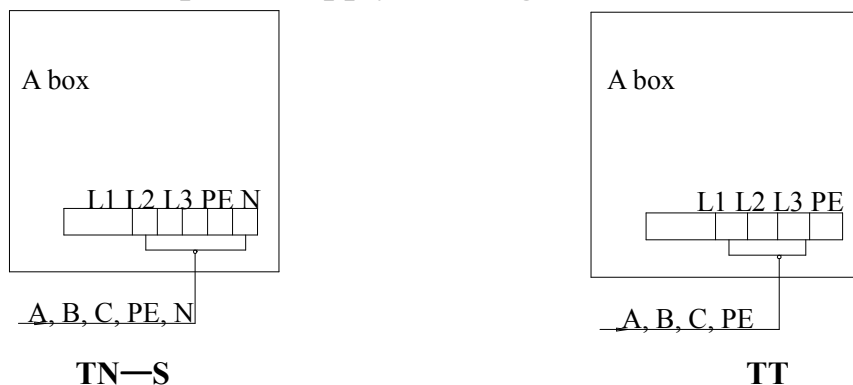

The tower crane must be earthed properly, no matter which mode of power supply is adopted.

2. Earthing

Attention: The earth wire of tower crane mustn't be replaced by fuse or the core of switch and cable.

There are three kinds of earthing modes:

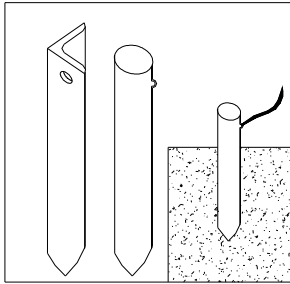

- A.** The earth substance adopts the standard earth stake, either use $\phi 33 \times 4.5$, 1.5m long steel tube or L70x70, 1.5m long angle steel.

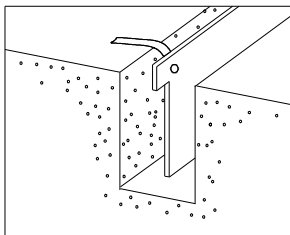

- B.** The earth plate is made of steel plate or other stretched metal plate with an area of 1m^2 . It was vertically inearthed 1.5m depth from the ground surface.

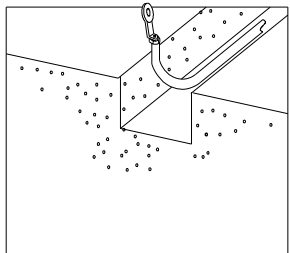

- C.** Copper conductor with cross section more than 28mm^2 or iron conductor with cross section more than 50mm^2 is inearthed in the wire casing. The inearthed depth is to be determined by earth resistance.

In above earthing modes, the copper conductor section coming from the earth substance should be more than 25mm^2 . If the soil conduction is poor, inearth sodium chloride (salt) in the soil and pour some water. For traveling type of tower crane, each section of rails must be electrical connected, and the two rails must be electrical connected. The earth resistance is less than 4Ω .

3. Power supply capacity and supply voltage requirement

The requirement of the lowest power supply capacity for each type of tower crane is determined by the hoisting winch. Because of the different hoisting operating conditions, the requirement of power supply is different. It should be determined by the lowest power supply (KVA) for each type of tower crane.

The requirement power voltage of **ST** series tower crane is in accordance with **CE138** and China National Standard: **50HZ, 380V±5%, 60HZ, 440V±5%**. This power voltage refers to the terminal voltage of Panel L during operating the tower crane. If the real power voltage is lower than terminal voltage, the capacity of transformer and the distance should be inspected and adjusted, or increase the cross section of power supply conductor.

| | |
|-----------------------|---------------|
| Type of tower crane | STT113 |
| Power supply capacity | 44kVA |

4. How to see electrical schematic diagrams

In the process of installing and service, it often needs to look up the electrical schematic diagram. In order to complete the installing and service work more quickly and accurately, the schematic diagram adopt letter symbols and graphic symbols in coordinate drawing which meanings could be find in the table 4-1-1 and 4-1-2. Horizontal coordinate numbers are under every electrical schematic diagram, there is a vertical line under every contactor (relay) coil graphic symbols, which marked coordinate numbers at both sides. It shows the quantity of main switch and auxiliary switch which the contactor (relay) used and the coordinate positions on the drawing. The number on the upper right quarter shows the position of auxiliary switch (contact). With transverse line above the number is NC switch (contact), and without this line is NO switch (contact). Arrow marked beside the number is time relay switch and the coordinate number marked at the lower left quarter of vertical line shows the position of main switch (contact). When a contactor (**relay**) was in working condition, look for the control position of contactor switches (**contact**) on the drawing coordinate as per number under the coil symbol.

5. Electrical schematic diagram symbol description (see table 4-1-1)

Table 4-1-1











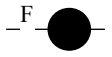
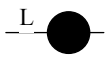
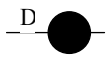
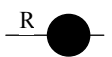
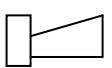
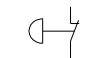

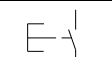

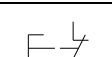
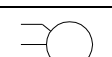
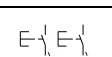
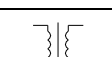

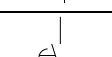
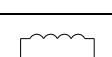
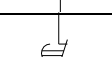
| Symbol | Name | Symbol | Name |
|-------------------|---|--------------------|---|
| I | Start button | O | Stop button |
| V ₀ I | Power indicator | CX ₀ RD | Left control panel zero switch |
| CX ₀ L | Right control panel zero switch | A | horn |
| Sh | Parallel connection hoisting limit switch | Au | Button for service |
| H、F | HF box connecting terminal | L | L box connecting terminal |
| XLH | Control panel switch for controlling hoisting | XL2 | Control panel switch for controlling medium speed |
| XLD | Control panel switch for controlling lowering | XL3 | Control panel switch for controlling high speed |
| SLChGV | Limit switch for high speed (proving ring) | SLChPV | Limit switch for max. load (proving ring) |
| SLMO | Lifting moment switch | SLH | Hook limit switch for highest position |
| SLD | Hook limit switch for lowest position | TSLA | LA panel control transformer |
| Red、Redx | Rectifier (silicon diode) | TSFUP | primary breaker for control transformer |
| RedFU | Rectify protective breaker | TSFU1 | Secondary breaker for control transformer |
| P | Main contactor | XBa | Switch for controlling lantern |
| XP | Main relay | CXL | Safety detecting relay |
| XL | Prevent over shift relay | Lfa | Contactor for controlling hoisting motor brake |
| LH | power supply contactor for lifting | LD | Power supply contactor for lowering |
| LMV | power supply contactor for low speed | LPV | Power supply contactor for medium speed |
| XLPV | Medium speed relay | SH | Parallel connection relay for hoisting |

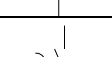
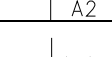
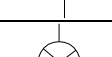
| Symbol | Name | Symbol | Name |
|---------------|---|---------------|---|
| LGV | Power supply contactor for high speed | XJ | Protection relay for loss of phase and phase sequence |
| XLGV | Control relay for high speed | LPV1 | Medium speed contactor |
| LFU | Control breaker for hoisting and lowering | Di | Main power supply switch |
| LVeM | Blower for hoisting motor | LM、PM、GM | Hoisting motor |
| LFs | Hoisting break | X1, X2, X3 | Lantern |
| TS1 | Control transformer | TS2 | Control transformer |
| TS3 | Auto transformer | FADi | Recitify overload protective switch |
| An | anemoscope coil | RXDAr | decelerating travel switch for trolley backwards |
| SDAV | Controlling travel switch for trolley forwards | RXDAV | decelerating travel switch for trolley forwards |
| SDAr | Controlling travel switch for trolley backwards | RDMO | Moment switch for trolley decelerating |
| SM | Parallel connection limit switch for trolley | SDMO | Moment switch for trolley stop |
| DMV | Power supply contactor for trolley low speed | XDAV | Control panel switch for trolley forwards |
| DMV1 | Power supply contactor for trolley low speed | XDAr | Control panel switch for trolley backwards |
| DFa | Control contactor for trolley brake | XDPV | Control panel switch for trolley medium speed |
| DAV | Power supply contactor for trolley forwards | XDGV | Control panel switch for trolley high speed |

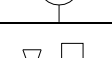
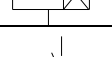
| Symbol | Name | Symbol | Name |
|---------------|---|---------------|--|
| DAr | Power supply contactor for trolley backwards | DPV1 | Relay for controlling trolley medium speed |
| DPV | Power supply contactor for trolley medium speed | PD | Contactora for controlling trolley blower |
| DGV | High speed relay for controlling trolley | DFS | Trolley brake |
| DRa | Eddy-current brake for trolley | DveM | Motor for trolley blower |
| DM | Trolley motor | Gt | Telescoping motor |
| DDi | Breaker for trolley main loop | XGi | Button for weather vane effect |
| XRGi1 | Relay for weather vane effect | RFa | Contactora for controlling slewing brake |
| XRGi2 | Relay for weather vane effect | T | Terminal strip |
| RD | Power supply contactor for right slewing | RG | Power supply contactor for left slewing |
| RRC | Silicon controlled rectifier | BSR | Thermostat |
| RFS | Slewing brake | RRa | Eddy-current brake for slewing |
| GiFa | Weather vane magnet coil | HveM | Motor for slewing blower |
| VGi | Weather vane indicator light | RM | Slewing motor |
| XRFS | Button for slewing brake | PXR | Slewing control potentiometer |
| SRG | Travel switch for slewing to the left | RDi | Breaker for slewing main loop |
| SRD | Travel switch for slewing to the right | SD | Parallel relay for trolleying and hoisting |

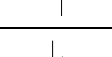
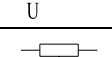
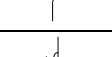
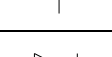
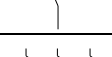
6. Electrical schematic diagram figure description (see table 4-1-2)

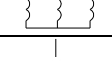
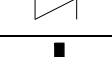
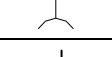
Table 4-1-2

| Figure | Name | Figure | Name |
|---|--|---|---|
|  | Connecting terminal (HF box) |  | Connecting terminal (HF box) |
|  | Connecting terminal (L Panel) |  | Connecting terminal (D box) |
|  | Connecting terminal (R box) |  | hailer |
|  | Circuit breaker (button switch for emergency stop) |  | Auto cut off switch for over loading |
|  | Button switch for closing |  | Maneuver switch (travel switch) |
|  | Control panel switch for lever operating |  | Button switch for breaking off |
|  | Asynchronous motor for squirrel cage type |  | Interlock switch |
|  | Transformer |  | Time closing when releasing operating parts |
|  | Brake DC exciting coil |  | Time closing when attracting operating parts |
|  | Eddy-current brake coil |  | Time lag trip when attracting operating parts |
|  | Coil for contactor and relay |  | Time lag trip when releasing operating parts |
|  | Contactor (relay) releasing the coil of time delay switch coil |  | light |
|  | Contactor (relay) acting the coil of time delay switch coil |  | Anemoscope |
|  | N/O switch |  | Varistor |
|  | N/C switch |  | Potentiometer |
|  | Main contact of contactor |  | Rectifier diode |
|  | Three phase autotransformer |  | Thyristor (silicon control) |
|  | socket |  | Socket |
|  | Cross connection |  | No cross connection |
|  | Earthing | | |

7. Wiring diagram and list of installing cable for tower crane (see fig. 4-1-1)

The consumer can install the cable according to this electrical schematic diagram (non traveling type of tower crane).

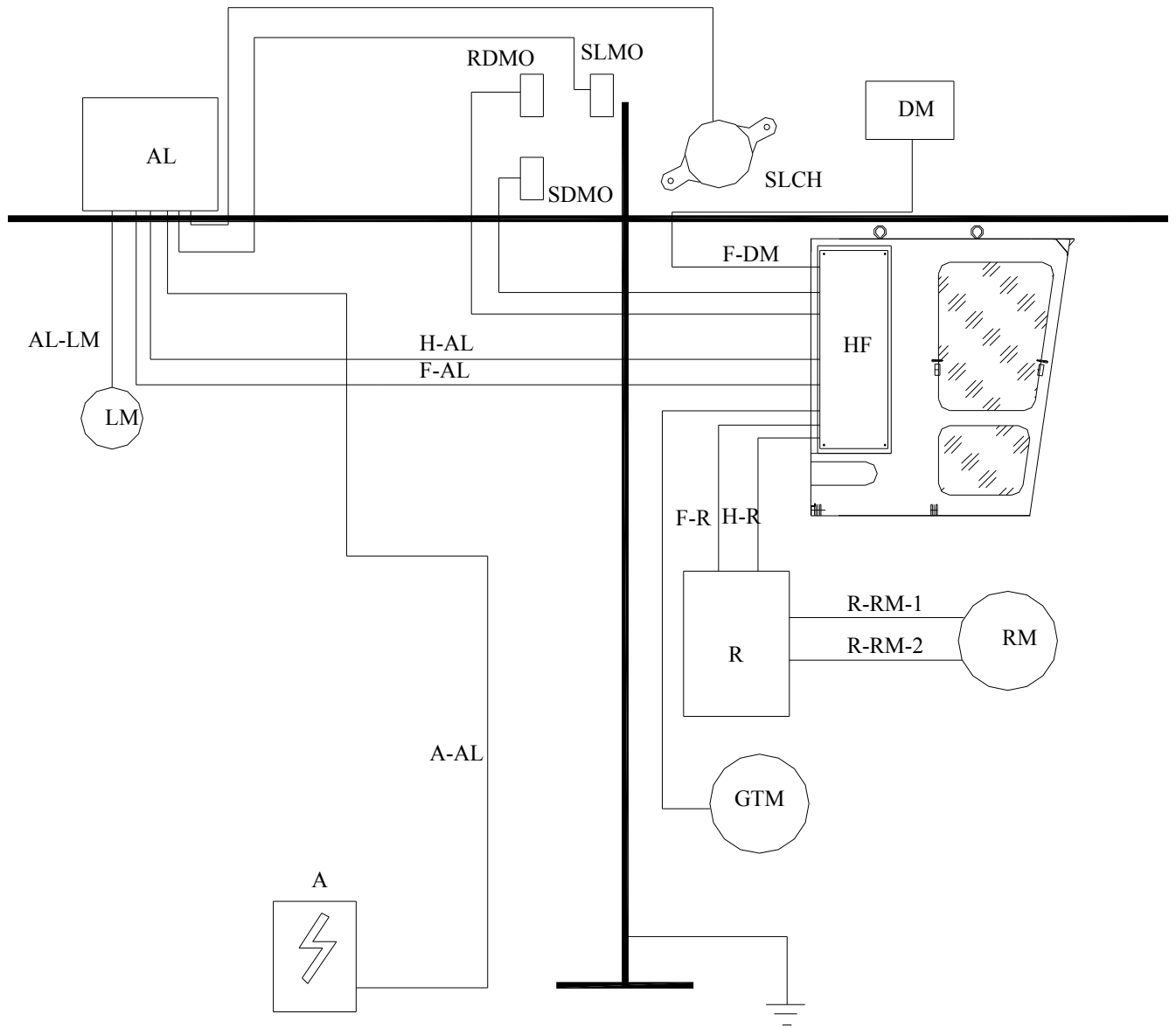

Fig. 4-1-1a

The consumer can install the cable according to this electrical schematic diagram (traveling type of tower crane)

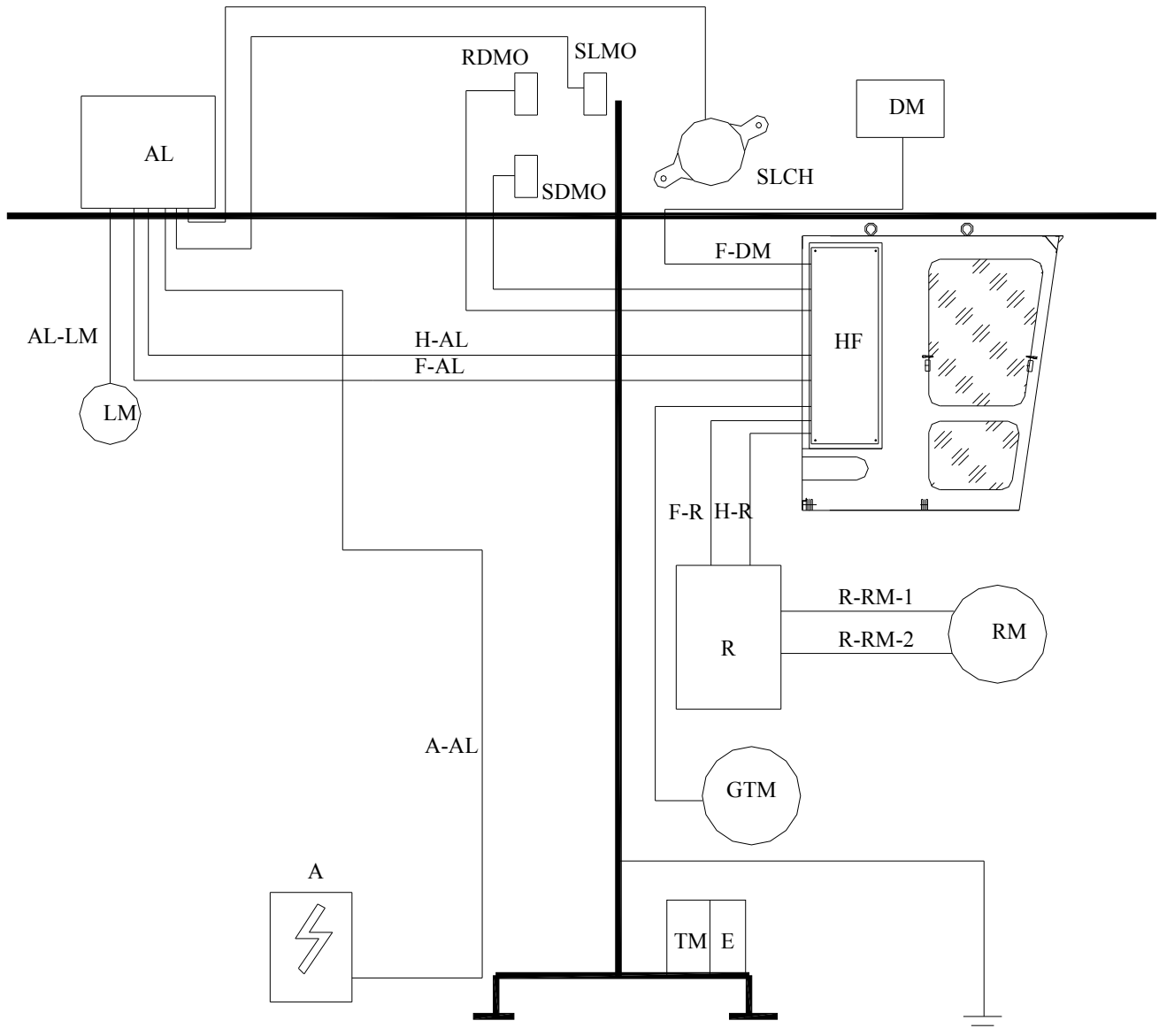
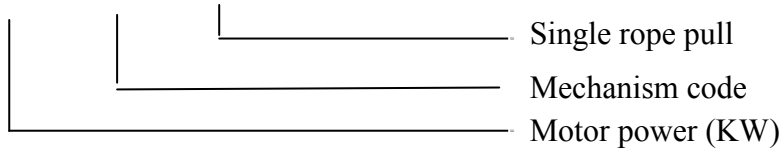

Fig. 4-1-1b

Chapter five Hoisting winch (24PQC15)

Symbol instructions:

□ P Q C □



● **Instruction:**

Keep the Min vertical speed when the rope pulled tight.

Keeps the Min lowering speed when put down the load.

Keep the middle speed when started to arise and be about to the end.

Keep the rated speed of motor in normal hoisting condition.

Select hoist speed according to the load: Raise a heavy load at low speed, and raise a light load at high speed.

Stop movement before the safety stop acting.

NOTICE: It is forbidden to put the hook on the ground. Loosen the steel rope slowly while placing a load.

Note: Reeving the rope must make tact, namely work three minutes and stop two minutes.

I composing of hoist winch

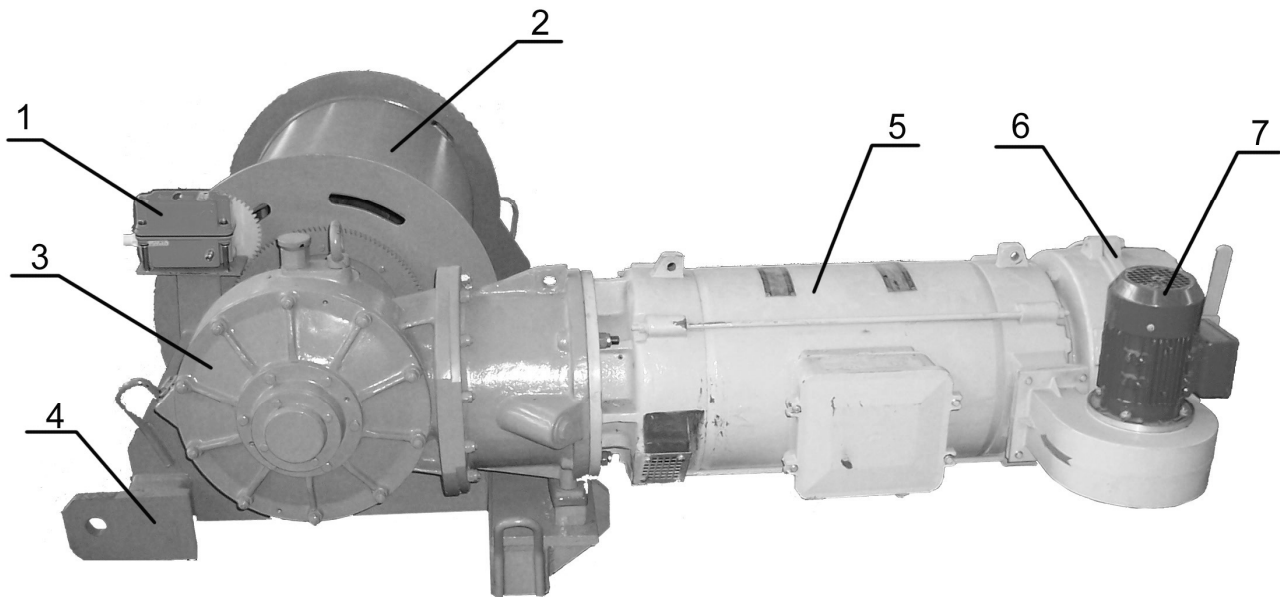

1. limiter

2. drum

3. reducer

4. undercarriage

5. motor

6. disc brake

7. cool motor

Fig. 5—1—1

1. Hoisting drum

The surface of drum have fold line score in order to limit the across enwind point of the each layer rope on the circle of the roller when reeve the multilayer rope, the two positions is at a distance of 180° , the others parallel reeve with the side plate of drum and may confirm the next lead angle of rope. It makes the load distribute uniformity between rope loop and reeve rope in order, reeve the multilayer (five layers) rope smoothly and tidily.

The drum passes the bearing of bearing block.

2. Drum

The reducer is making up of the spiral bevel gear pair and primary planet gear pair, the box of reducer linked with the frame.

3. Motor

The three speed motor is TSYDE180L – 2/4/16. The output of motor is 24/24/5.5KW. There is a disk electromagnetic brake on the tail section of motor.

the motor is make up of the three stator winding and its rotate speed are: 2800r/min. 1400r/min and 300r/min

4. Hoisting limiter

This winch equip with the DXZ4/7 type multifunction traveling limiter, the drive ratio is $i=1:274$. adjusting limiter related in the chapter “safety device”.

II. Characteristic parameter

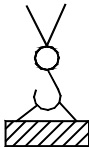
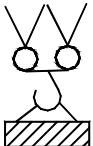
| | | | | |
|--|---------------------------------|------------------|----|-----|
| working level | | M5 | | |
| using grade | | T4 | | |
| load condition | | L2 | | |
| motor type | | YSYDE180L-2/4/16 | | |
| motor speed/min | | 2800/1400/300 | | |
|  | raising speed and load m/min | 80 | 40 | 8.5 |
| | t | 1.5 | 3 | 3 |
|  | m/min | 40 | 20 | 4.2 |
| | t | 3 | 6 | 6 |
| rope diameter | | 12mm | | |
| rope capacity of drum | | 400m | | |

III working principle of hoisting winch

Three speed motor of hoisting winch drive the drum to running by reducer.

The electric interlock control panel control the hoisting winch to carry out three raising speed and three lowering speed. It is low speed, intermediate speed and high speed. When start up the low speed motor (16 grade), the stator winding and disk brake coil be made contact simultaneously, declutch the brake then startup the hoisting winch by low speed (MV), Thereafter, its may switch to the intermediate speed motor(PV) and may continue switch to the high speed to work.(GV) in light load condition.

When stop motion, the electric control make the time which the brake affected lag 0.5—1s in order to prevent braking intensively to damage brake.

The intermediate speed shift (PV) and high speed shift (GV) of hoisting winch is work shift. The low speed (PV) used to start up and low location, generally it is not allow work long time.

IV Adjusting brake of three speed hoisting motor (see Fig. 5-1-2)

(I) . Adjusting brake moment as following:

1. takeoff pin (54) and plate (53);
2. Takeoff manual adjustable lever (52);
3. takeoff the bolt (29);
4. takeoff whole cover cap (40);
5. Tighten up three spring adjusting nuts (37) simultaneously. The travel motion distance of three nuts is same when adjusting three nuts, precession the nut according to the clockwise, the brake moment increased; precession the nut according to counter-clockwise, the brake moment reduced. It's until hoisting max rating load, the load till not subsiding.

(II) . Adjusting air clearance of brake as following:

1. takeoff cover cap (40);
2. Loosening the nut (39) and (45), adjusting the distance between yoke iron of electromagnet (47) and gag bit (59) is 0.7—0.8mm. the clearance tolerance around is less than 0.05mm, After tighten up the nut (39) (45) should check the clearance dimension to accord with the demand. when operation adjust again and again.

(III) . exchange the friction disk as following:

1. Takeoff cover cap; (40)
2. screw off the nut; (45)
3. Takeoff electromagnet; (47)
4. screw off nut (39) (37);
5. Takeoff sprig (35);
6. Takeoff gag bit (59);
7. Takeoff brake holder block (33);
8. when it is fitting cleanup the raffle and dust of each parts surface.

(IV) . declutch method of machinery:

In good running, the adjustment cover (55) of the brake end should in loosening condition, not to be tightly, in special condition, such as power cut, damage the motor, can declutch automatically and put the hook on the ground as following method:

Takeoff the pin (54), plate (53), tighten up the adjustment cover (55) to the hook fall off.

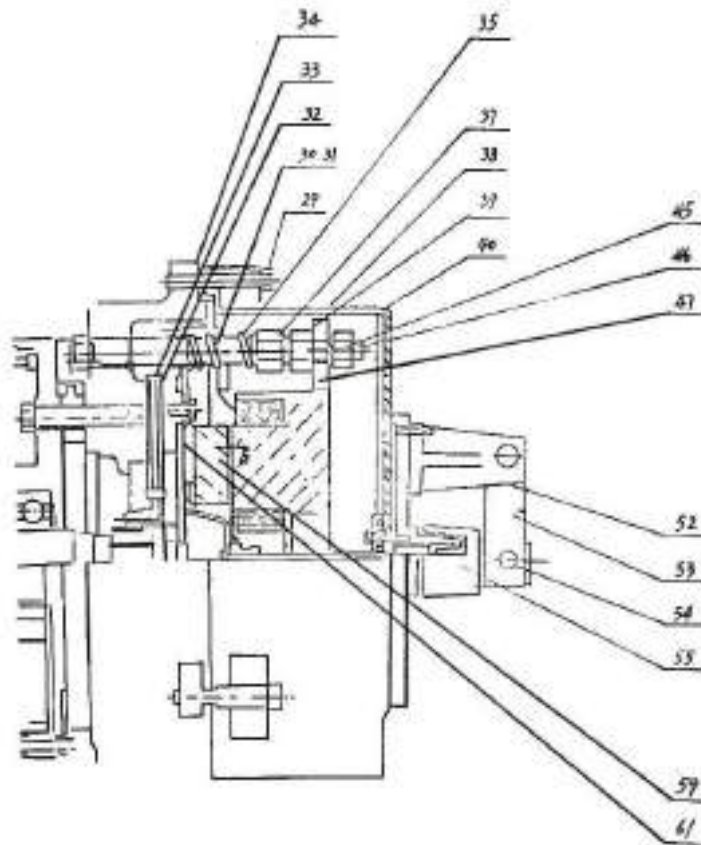

- | | | |
|-------------------------------------|---------------------------|--------------------------|
| 29. Bolt | 32. Underplate of gag bit | 33. Brake holder block |
| 34. Fixing cover of brake | 35. Compression spring | 37. Spring adjusting nut |
| 39. 45. Electromagnet adjusting nut | 40. Cover cap | 46. Bolt |
| 52. Manual adjustable lever | 53. Check plate | 54. Shaft pin |
| 55. Adjustment cover | 59. Gag bit | 61. Bolt bar |
| | | 47. electromagnet |

Fig. 5-1-2

V. Maintenance and servicing of hoisting winch

1. Check carefully according to following table before daily operation:

| Check item | Requirement |
|-----------------------|--|
| Reducer | Oiling according to code designation and oil capacity (18 # distillate hyperbolic gear oil) |
| Rope | Array in order and have no breakage, broken rope, extruding and distortion, end fixity is fastness. |
| Jointing element | Anchor screw is not loosening and not missing parts, linking the pin end to fixing and prevent fall off. |
| Limiter | The hook limit position correctly. |
| Every lubricate parts | In the good lubrication condition (see the chapter tower servicing) |

2. Reducer oiling

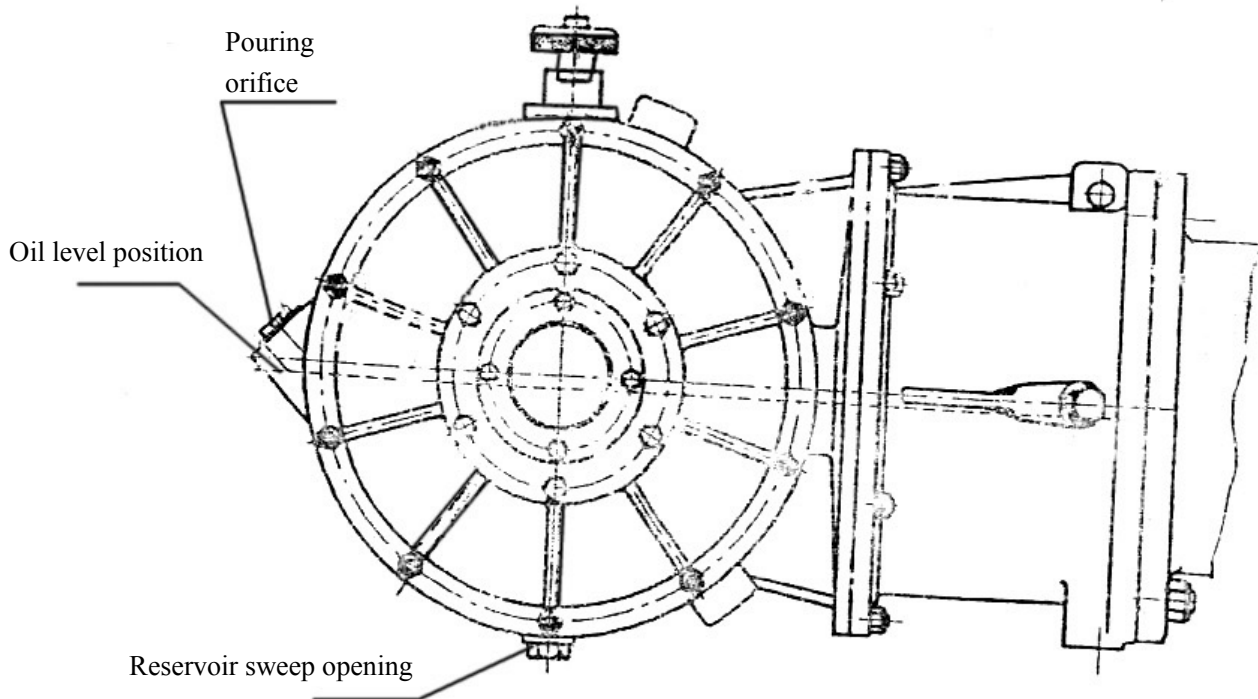

Fig. 5-1-3

Filling up the 18 # distillate hyperbolic gear lubricant to the oil level according to the demand. The crane should check the oiliness and oil level position after operated each 200h and filling up the oil to the oil level; operated the 2400h should emptying the oil, cleaning up and renewal the clean oil.

3. The crane should adjust the clearance between the brake moment of disk brake for motor, brake holder block and brake disc after operated one week. Demanded the brake moment of brake $\geq 175\text{N.m}$, the clearance between brakes is 0.8mm. Check the brake whether sensitivity before operate the crane every day.
4. If the motor found unusual noise in operation should stop and check immediately. When the vibrate and noise increase obviously should check the bearing of motor, if the play more than 0.1mm should replacing the new bearing and keep the grease in bearing simultaneously.
5. There is grease fitting on the each outside of the bearing block for barrel arbor two end, the crane should filling up the 2 # lithium grease after the crane operated 200h every time.

Chapter VI Slewing mechanism

| | |
|---|--------------|
| I. Explanation of symbols | 6B-2 |
| II. Composition of slewing mechanism and its working principle | 6B-2 |
| III Working principle of controller RTC | 6B-4 |
| IV. Operating and fault clearance of slewing mechanism RTC | 6B-5 |
| V. Slewing brake | 6B-8 |
| 1. Manual brake release | 6B-9 |
| 2. Electric starting of weather vane device | 6B-11 |
| 3. Service and maintenance of slewing brake | 6B-12 |
| VI. Wiring chart of R box | 6B-13 |

I. Explanation of symbols

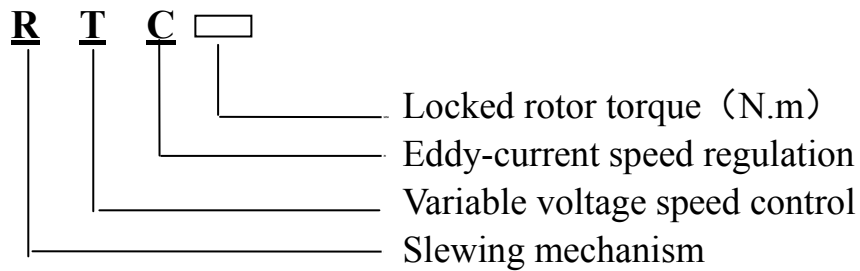

Description:

Select the slewing speed according to the required displacement. Accelerate or decelerate the slewing speed gradually. When stopping the jib, speed down first and then stop the slewing operating. It is forbidden to stop the jib by slewing brake, which is only used to position the jib for hoisting when wind speed is less than 13m/s. Prevent wire rope from distorting when slewing the jib and hoisting the load are carried out at the same time.

II. Composition of slewing mechanism and its working principle

The slewing mechanism is composed of moment motor and planetary reduction gear (see Fig. 6-2-1). (It adopts electronic voltage regulating control system. The speed is adjusted via adjusting supply voltage of the stator for moment motor, the eddy-current brake and the eddy current. The slewing driving system is composed of moment motor and planetary reduction gear. The moment motor is with eddy current brake and weather vane brake. Weather vane brake can be brake and released automatically or manually. Electromagnetic brake is released when power on, and brake when switch off. After slewing operation, the brake is always released when power on. During operation, adopt the slewing brake in specific conditions to protect the crane from wind. The slewing brake must brake after the slewing stopped completely when wind speed is less than 13m/s. **After one day's work, open the weather vane electromagnetic brake automatically or manually, make the tower crane enter into weather vane effect.**

The armature of bow wave brake of the motor runs with shaft. The Electromagnet of bow wave brake produces magnetic field in the air gap δ_1 around the armature when the excited loop was supplied with direct current. The armature incises the magnetic field so as to form potential field, and then current (that is bow wave) is obtained. Because of the action of the magnetic field of bow wave and the magnetic field of Electromagnet to one another, produce brake moment that is **directly proportional** to excited current and rotate speed of the armature. Regulating excited current and voltage of motor carry out stepless speed regulation of the motor.

1. moment motor
2. planetary reduction gear
3. weather vane brake
4. slewing ring
5. travel limiter
6. eddy-current brake

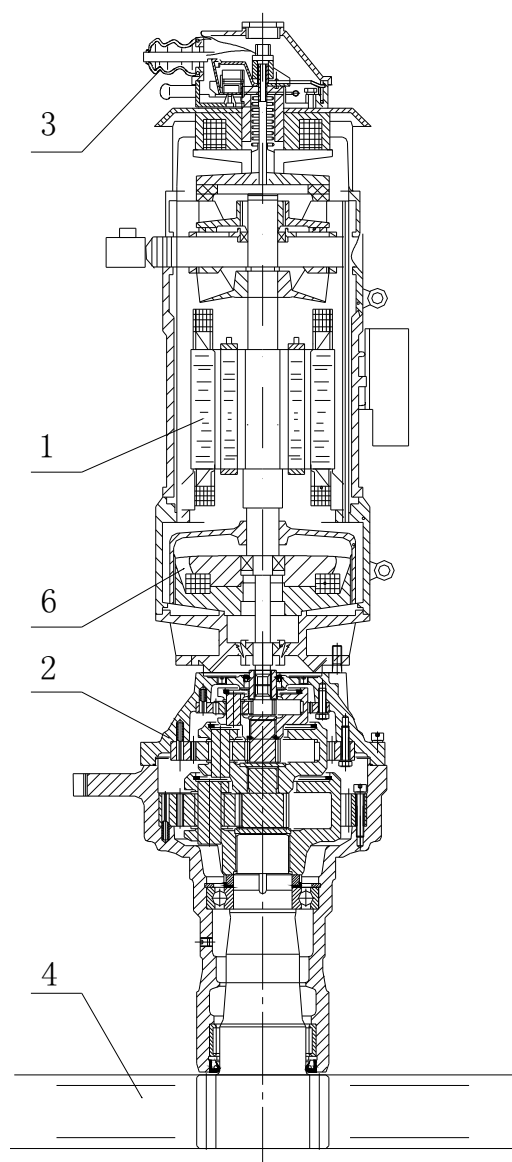
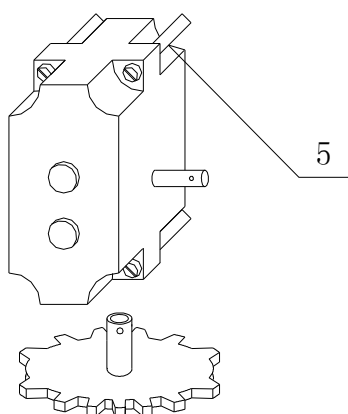
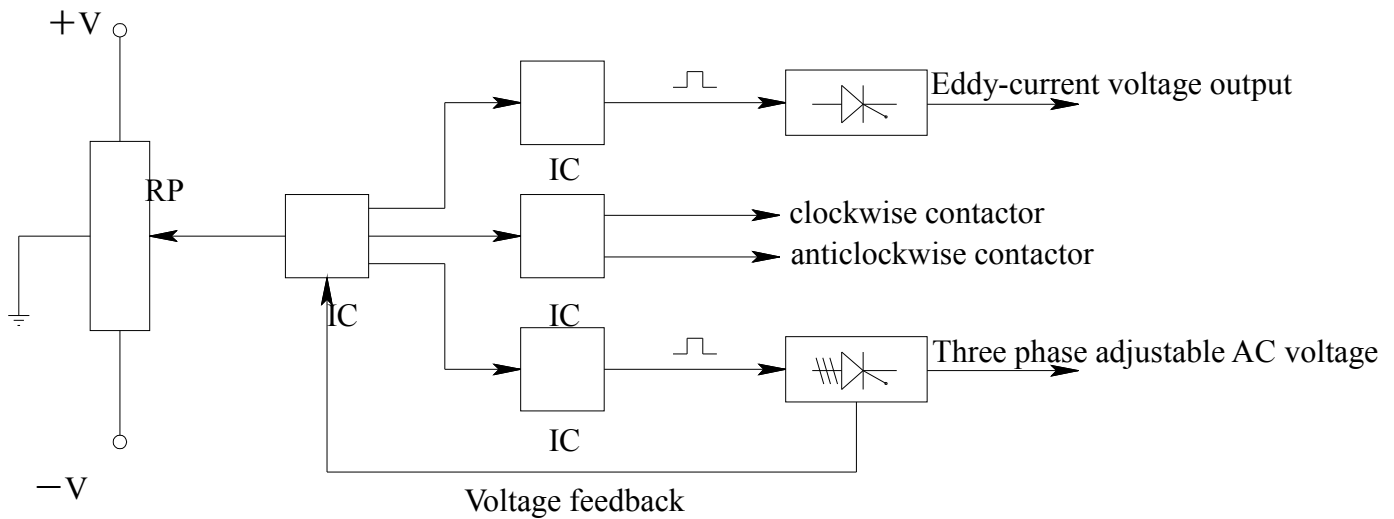

Fig. 6-2-1

III Working principle of controller RTC



Control functional block diagram

The potentiometer RP in interlock operation desk setting phase shift triggering control voltage of crystal brake tube then could output three circuit signals by the amplifier IC. The first circuit striking uniphase crystal brake tube of eddy current brake to adjust the exciting voltage of eddy current. After the second circuit magnify by amplifier according the voltage polar to decide position and negative turning of motor. The third circuit striking the six crystal brake tubes by the triphase triggering and make the motor gain the linear change voltage, then make rotate speed stepless change, idiographic circuit as follows:

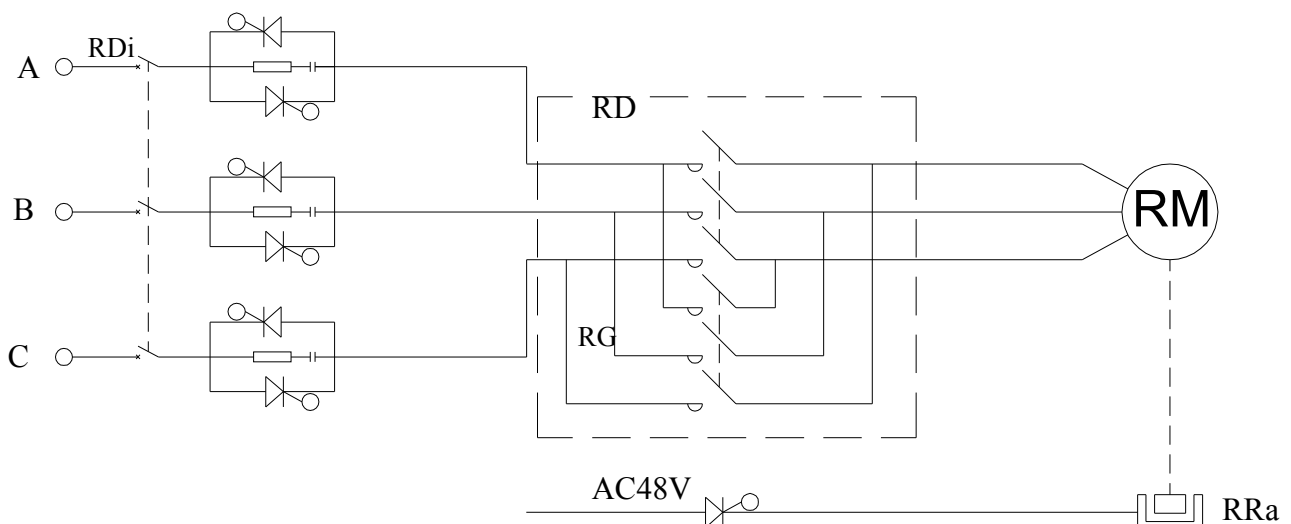

IV. Operating and fault clearance of slewing mechanism RTC

1. Notice for operating RTC

- 1) This slewing mechanism adopts specific slewing controller (electronic block) in control loop. It can automatically ensure the stably acceleration and deceleration when starting up or braking, it also can prevent the tower crane from abnormal running, such as emergency stop, suddenly reversion. Thus, it is very important for the correct and reliable wiring of slewing controller (electronic block, control
- 2) Check up and maintain regularly, before clearing the failure, it is forbidden to use the crane any more. Otherwise, it may cause serious damage for driving parts and structural parts, even result in serious accident.

2. Failure diagnosis and service methods for RTC mechanism

When operating the RTC mechanism in normal range, if the slewing is in abnormal condition, cut off the power first, and then inspect from the following aspects:

- 1) The crane can but running in single direction, after stopping a period of time, another direction can running, after running a period of time, only running in single direction again. If in such condition, stop the crane immediately and cut off the power to check that whether the two lines between joystick and electrical control panel, center tap of potentiometer and earthing terminal connected up.
- 2) The slewing running of tower crane in one direction is fast than another; or once switched on the slewing air switch RDi, the slewing rotated towards one direction. If in such condition, cut off the power immediately and check that whether the potentiometer line broken or circuit broken. In addition, it maybe offset the zero position. Measure the resistance of center tap end and sliding end by multimeter in X1 gear, if the resistance is not between 0~50Ω, readjust the zero position of potentiometer.

- 3) There is noise and joggling in the slewing motor. In this condition, power on and check that whether the voltage three phase for motor is lack phase; whether the three phase voltage is balanced. In normal condition, the degree of unbalance for three phase voltage shouldn't be more than 3%, i.e. the voltage of three phase output line can't exceed 15V. If the declination is too large, replace the slewing controller.
- 4) The slewing system start up rapidly and stop slowly. If in such condition, stop the tower crane and check that whether the exciting voltage of eddy-current RRa is about 20V DC. If the voltage is too low, check the AC voltage (48V) which entering into the thyristor module. If there is no voltage, cut off the supply and check the connecting line in this part; check again whether the thyristor module is damaged.

The inspection methods are as follows:

(1) The resistance between gate electrode G and cathode K should be 7~100Ω.

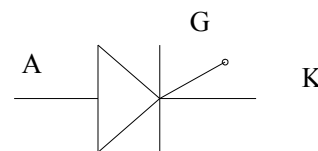

(2) The resistance between the anode A and cathode K is infinitely great.

If there is no above mentioned problem occurred, please replace the slewing controller.

- 5) After the control lever back to zero, there is a contactor (RD or RG) didn't power down. It need to cut off the power and check the zero position of potentiometer. Pull out the inserted piece between controller and mother board of thyristor. Measure the resistance between earthing terminal and sliding end of potentiometer by multimeter. If the resistance is infinitely great, replace the potentiometer.

6) positive turn and negative turn contactor(RD or RG) don't close.

First, check the connection whether loosen or broken line; next supply power and check the sliding end of potentiometer RP should have plus minus constant voltage (when the handle operate), if have no voltage output, lookup potentiometer both end point should have plus minus constant voltage, if there isn't voltage input, the controller have problem. When above check normal, need check RD or A₁ end of RG contactor should have 48V voltage under the operate handle condition and farther check the controller have 48V voltage, above check normal, please replacing the slewing controller.

7) Slewing controller and crystal break tube both burn and turn black, please check the modular first then check the power supply voltage whether overtop. Please replacing the slewing controller if above check all normal.

V. Slewing brake

1. Manual brake release (see fig. 6-4-1)

1) Start the weather vane device:

- a). Raise the brake lever (1), i.e. act A.
- b). Push the button (2), and make it stay under the brake lever (1).
- c). Release the brake lever (1), and make it stay on the strap clamp (3), then the brake lever was locked by brake lever. Finally, pin the strap clamp.
- d). Release the pressure on the push-button (2). No clearance is allowed between the button and the brake release lever (1). Otherwise the operation must be carried out again. Readjust if the clearance still remains.
- e). When the weather vane effect has accomplished, the slewing mechanism should be allowed to rotate freely.

2) Release the weather vane device

- a). Raise the brake lever (1), i.e. act A.
- b). Under the action of spring (4), the strip clamp (3) came out.
- c). Release the brake lever (1).
- d). When the weather vane effect has accomplished, the slewing mechanism should be stand still.

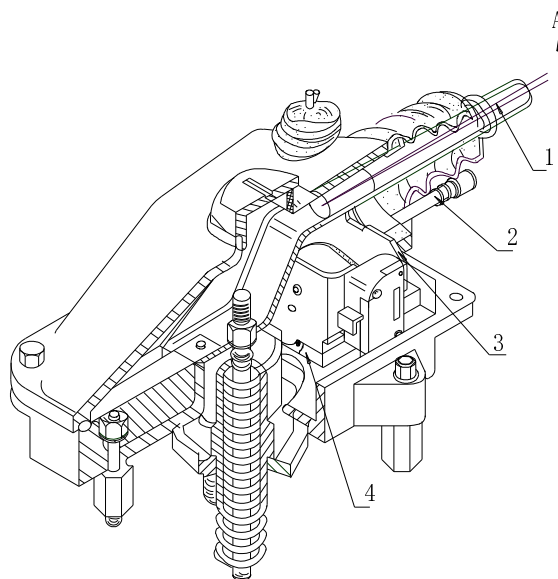
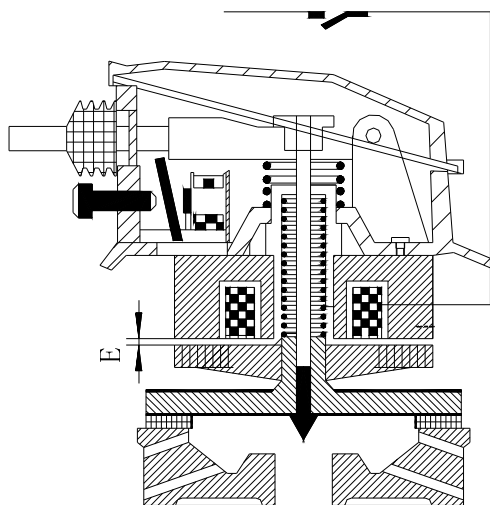

Fig. 6-4-1

3. Working principle

1. Brake engaged



2. Brake released

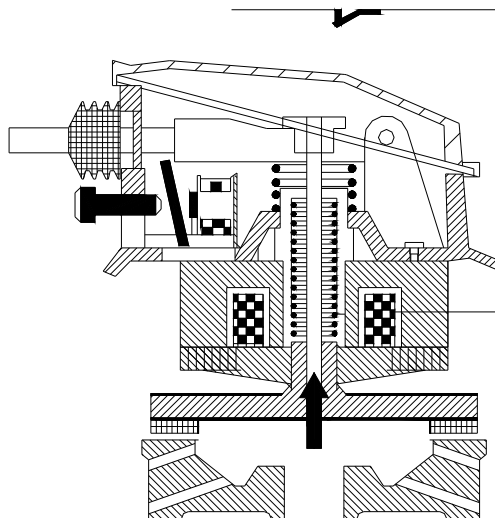

Note: “E” is the clearance of brake, which value must be kept between 0.8-1.2mm.

Adjust it if necessary.

2. Electric starting of weather vane device

Description: It is an electromagnetic brake, which is braked when switched off. It has independent power supply.

Working principle

1. Brake engaged

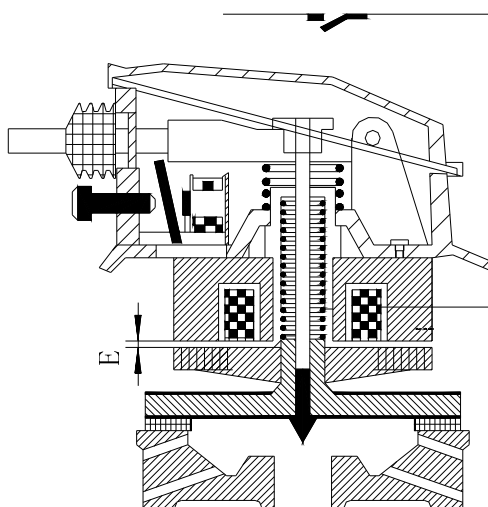

2. Brake released

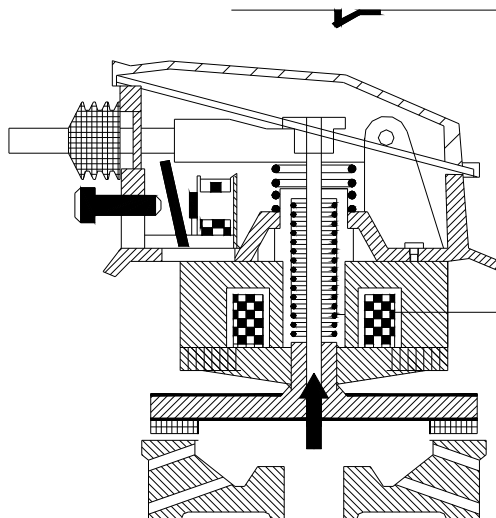

3. Service and maintenance of slewing brake

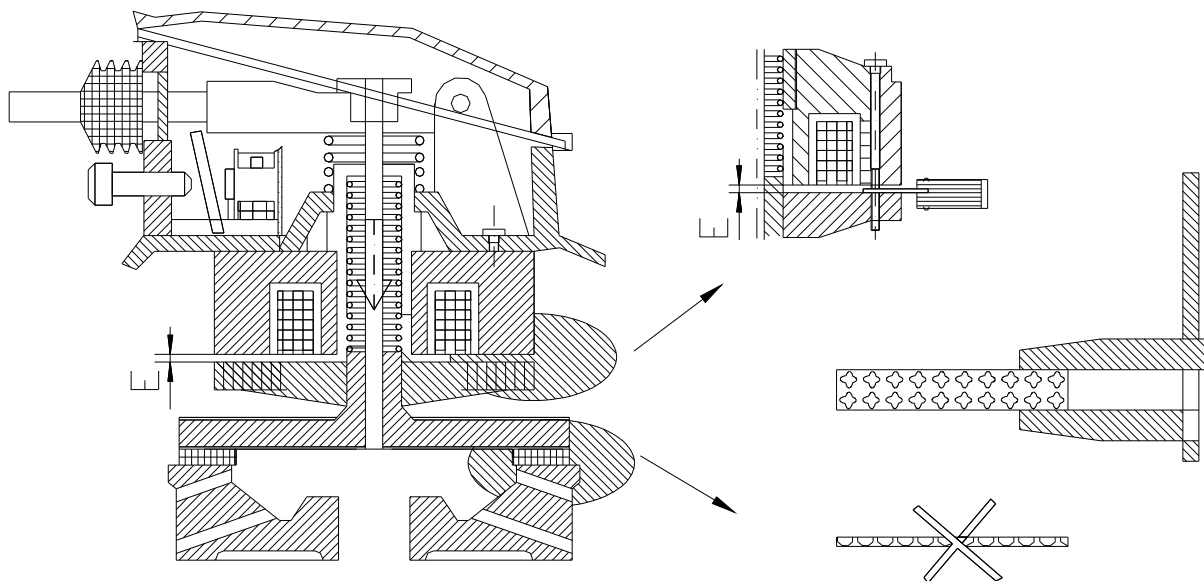

Attention: There shouldn't be any foreign substance in the brakes (such as cement, sand, grease, etc).

1) Unscheduled maintenance

The adjustment and maintenance should be carried out under the following conditions:

- a). Insufficient braking moment which is caused by worn brake disc.
- b). The indicator is out of work.

2) Scheduled maintenance

- a). Every 200 hours or every one month once.
- b). Check the clearance and brake moment, as well as the worn condition of the brake disc, replace it if necessary.
- c). Check that whether there is some foreign substance in the brake (such as cement, sand, grease, etc).

VI. Wiring chart of R box (see fig. 6-5-1)

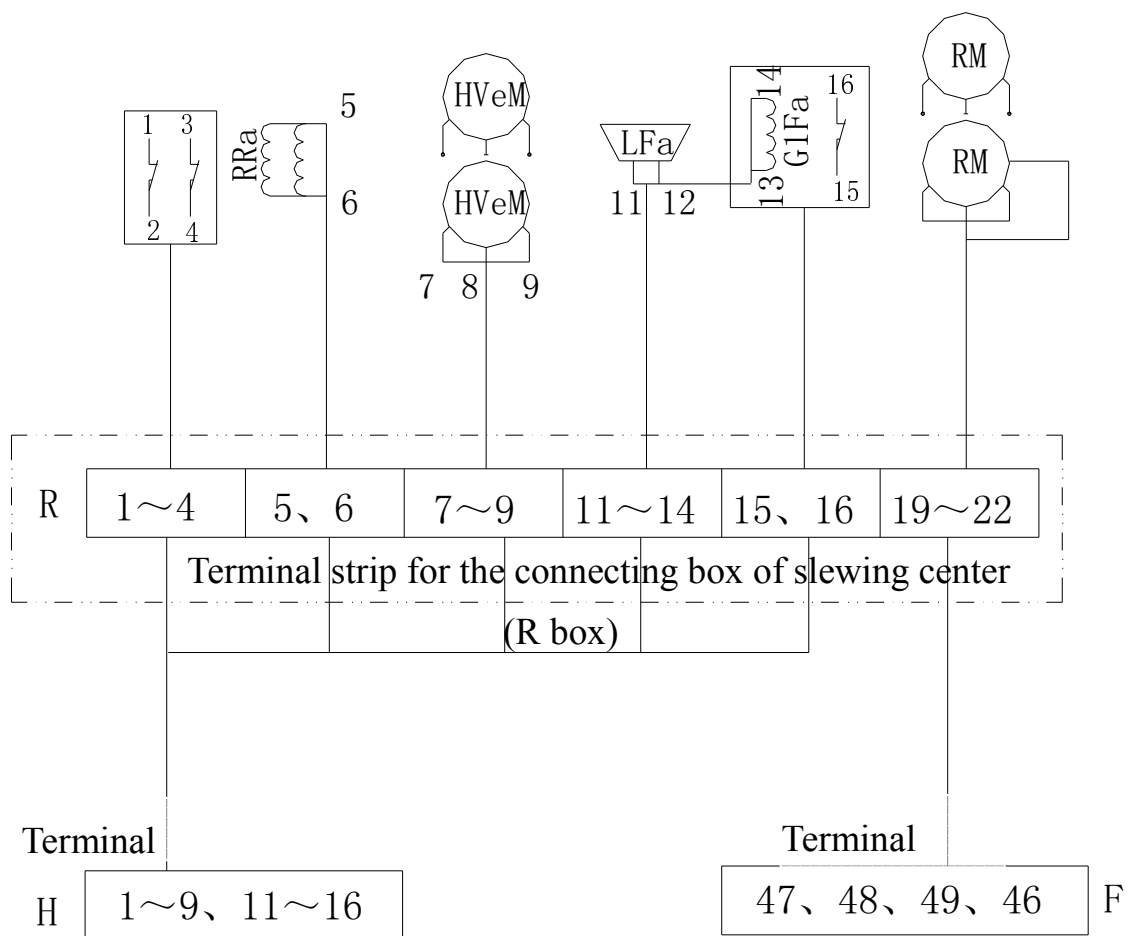
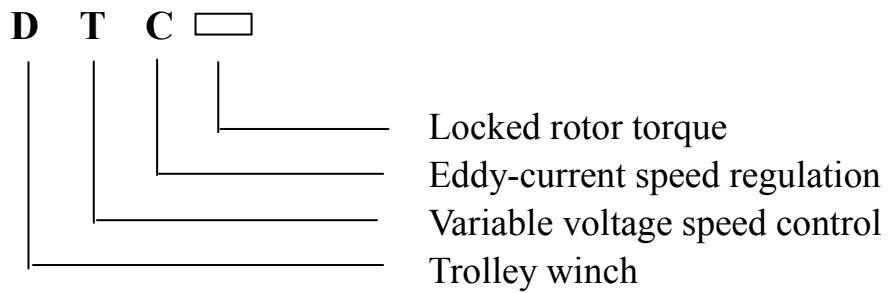

Fig. 6-5-1

Chapter VII Trolley winch

| | |
|---|-------------|
| I. Explanation of symbols | 7B-2 |
| II. Composition of trolley winch and its working principle | 7B-3 |
| III. Trolley brake | 7B-5 |
| 1. Working principle of trolley brake | 7B-5 |
| 2. Maintenance | 7B-6 |

I. Explanation of symbols



Description:

The trolley speed should be selected in accordance with the trolley distance. It is necessary to acceleration or deceleration gradually.

II. Composition of trolley winch and its working principle

Trolley mechanism **DTC** consists of a drum, a planetary reduction gear and an torque motor on which shaft extension end, and rear end respectively equipped with a bow wave brake and a disc brake supplied with direct current, (see Fig.7-1-1). Taking advantage of various resultant of moment characteristic and bow wave brake, the trolley mechanism driven by the torque motor allows 3 speeds. The first speed **MV** is obtained by the resultant of field excitation of bow wave brake and running of the motor under voltage drop (230-260V). The second speed **PV** can be obtained by resultant of field excitation of bow wave brake and running of motor under rated voltage (380V). When the motor run under rated voltage (380V) and bow wave is without field excitation, the third speed **PV** is obtained.

When the trolley mechanism begins running, the winding of electromagnetic brake remains current-fed so that gag bit is attracted. The motor brakes as the current is cut off. The movement clearance for the gag bit of the brake is 0.8-1.2mm. Adjustment of the movement clearance is similar to that of the brake of slewing motors. Adjustment of locking torque of the brake is carried out by adjusting spring canister (14). Proper torque clearance can maintain the heavy load under control and the attraction without any difficulties at the same time

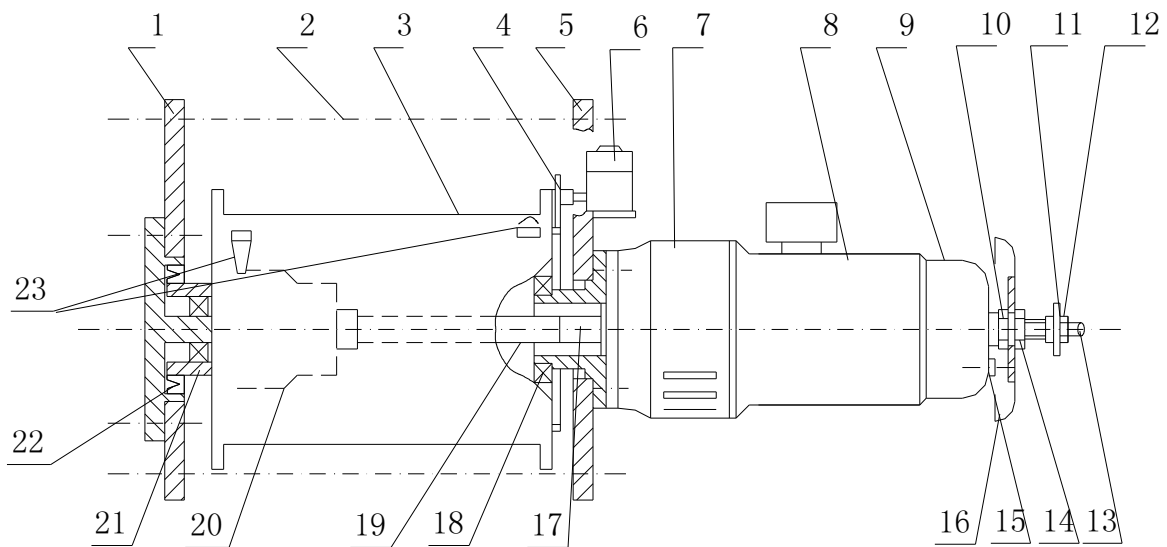

Fig. 7-2-1

- | | |
|--|-----------------------------------|
| 1. Outer support plate | 2. Connecting bar |
| 3. Drum and cabinet for reducer | 4. Pinion for travel switch |
| 5. Inner support plate | 6. Travel switch DXZ-4/FW |
| 7. Eddy-current brake for motor, exciting voltage DC20V | |
| 8. Motor, synchronous speed 1500r/min | |
| 9. Brake of motor, field exciting voltage DC20V | |
| 10. Locking nut for wind tunnel shield | |
| 11. Hand wheel for manual release brake | |
| 12. Nut M8, which locked the hand wheel in service | |
| 13. Screw M8, which simultaneous running with brake disc | |
| 14. Spring pipe which used to adjust the spring pressure of the brake | |
| 15. Pin for locking screw of the brake disc, which inserted in the third and fourth hole of brake disc | |
| 16. Protective cover | |
| 17. Spline housing (coupling piece which connect the motor and transmission shaft) | |
| 18. Bearing 80212 | 19. Transmission shaft |
| 20. Reducer, nominal speed ratio $r=30.36$ | 21. Bearing 60209 |
| 22. Reinforced seal PD115x140x14 | 23. Fixing wedge for trolley rope |

III. Trolley brake (see fig. 7-3-1)

Description: It is an electromagnetic brake, which is braked when switched off. It has independent power supply.

1. Working principle of trolley brake

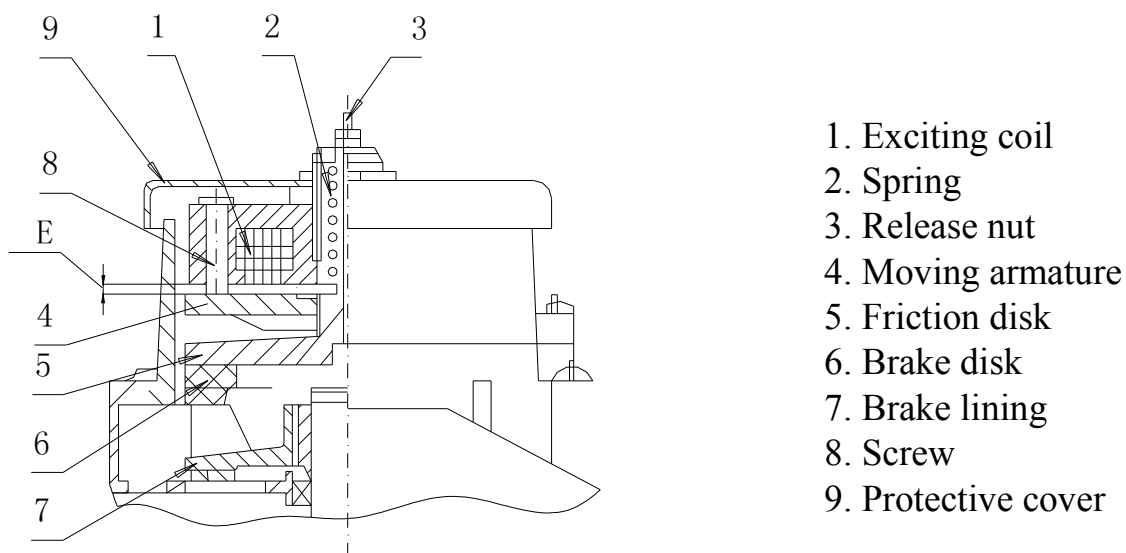

Fig. 7-3-1

Braking: When the exciting coil switching off, the electromagnetic attraction disappears, The brake spring (2) pushes the friction disc (5), then the brake disc (6) enters into brake state.

Brake release: When current entering into the exciting coil, the armature is attracted, which drives the friction disc (5), compress the spring (2), and make the brake disc entering into releasing state. The brake is ready for next brake when the current is cut off.

Clearance adjustment: Remove the protective cover (9) and screw (8). Move the disc by screw, until it lean against the cover of the latch. Move the disc again, and locked it in the 3rd. At this time, the clearance is 0.8 to 1.2mm

Brake moment adjustment: It is already adjusted in the manufacturer.

Manual brake release: Tighten the release nut (3). Do not forget to unscrew the nut when restarting.

2. Maintenance

- a). Every 200 hours or every one month once.
- b). Check the clearance and brake moment, as well as the worn condition of the brake disc, replace it if necessary.
- c). Don't replace the brake until it worn out completely.
- d). Check that whether there is some foreign substance in the brake (such as cement, sand, grease, etc).

The motion procedure diagram for relay and contactor of trolley winch

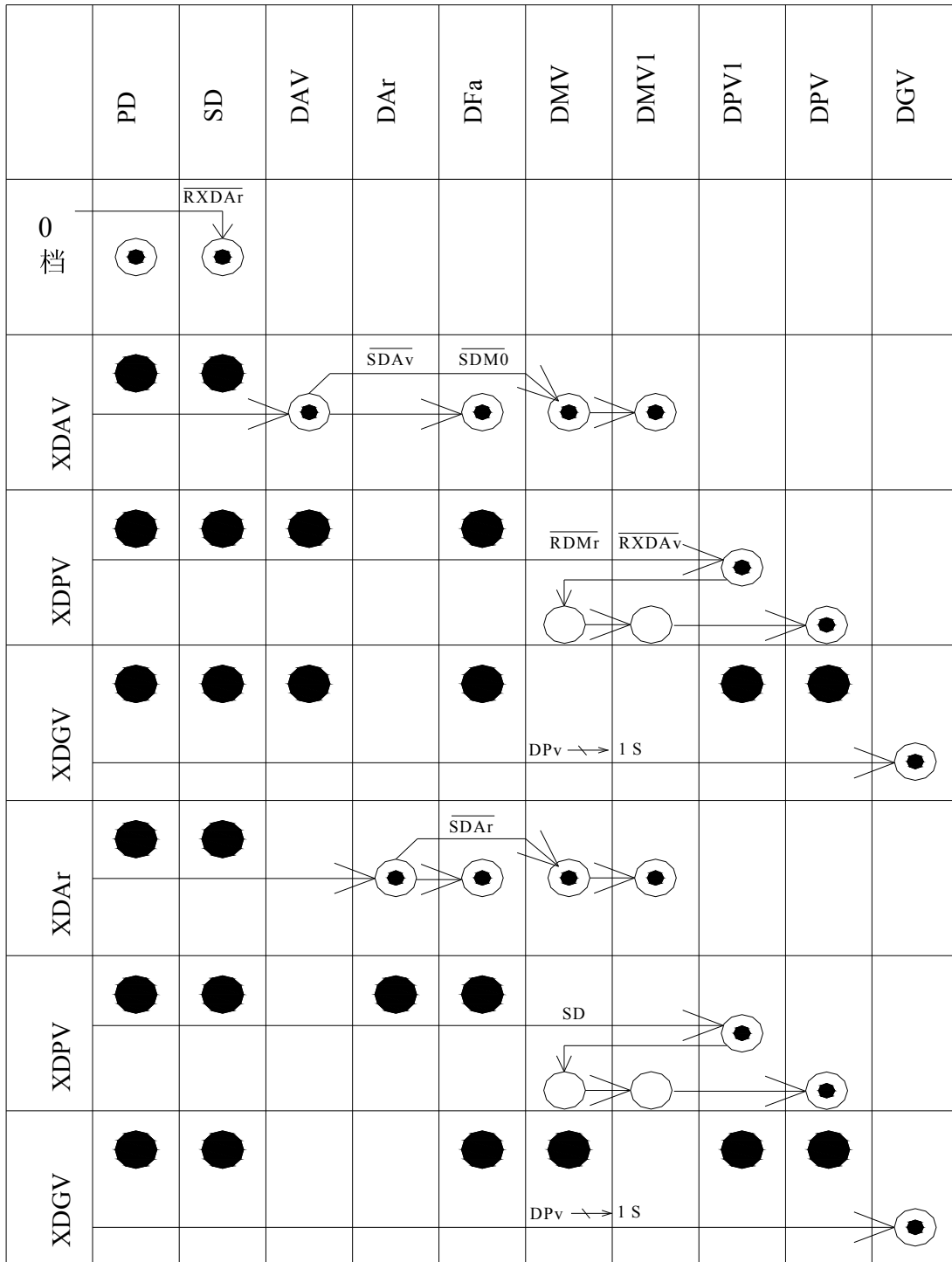

- Attracting when power on
- Keep former attracting state
- Release when power down

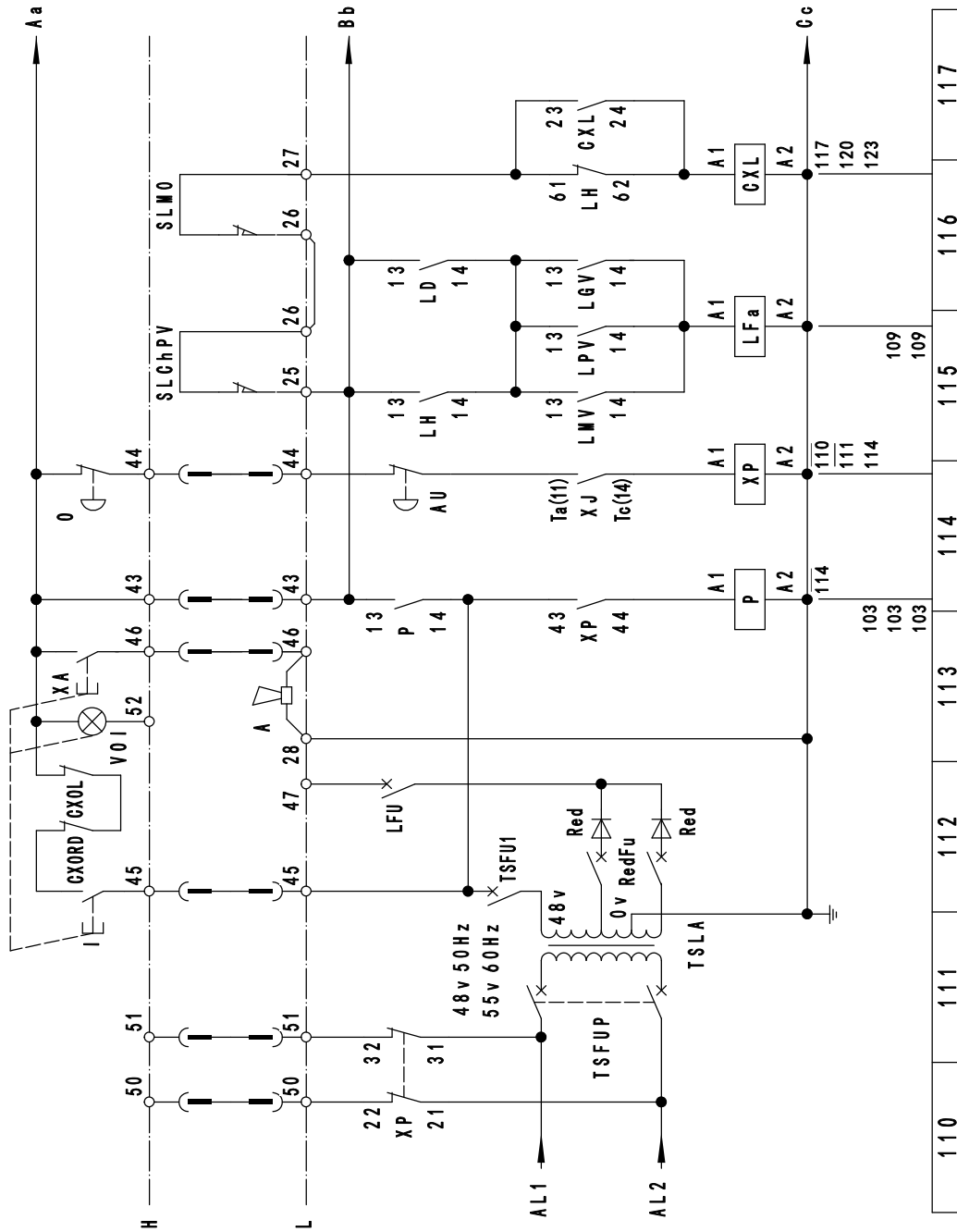

ALPC-D515B-1

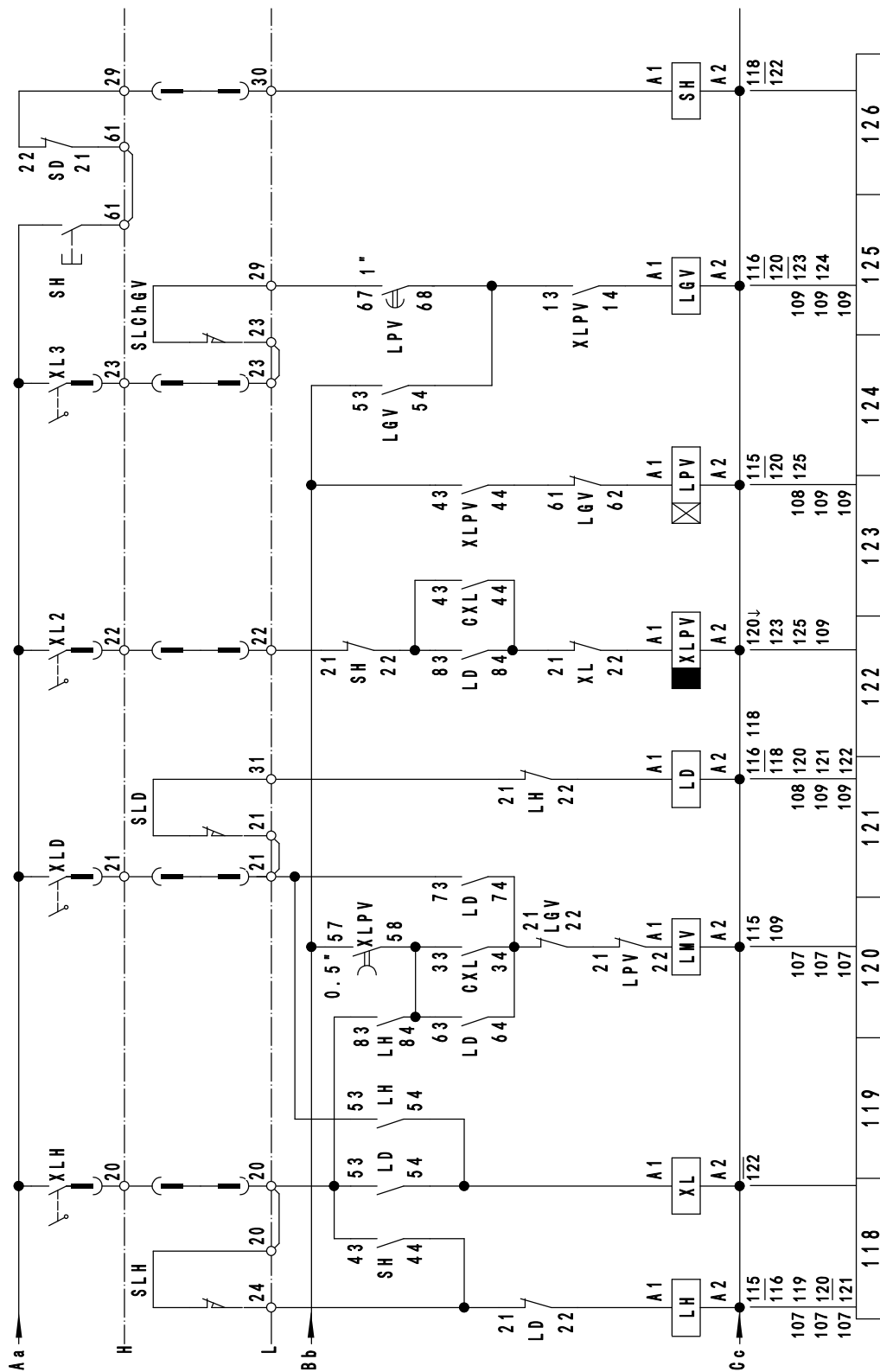

ALPC-D515B-2

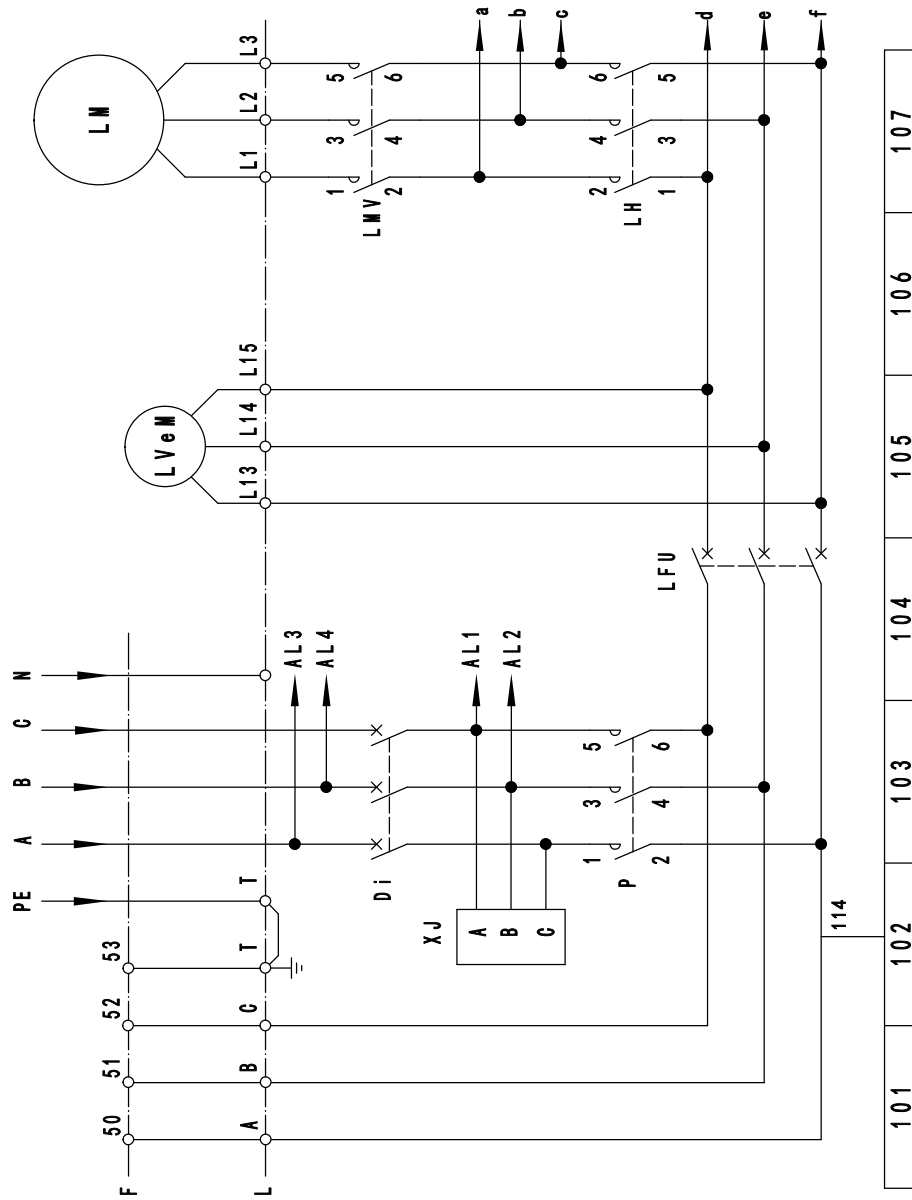

ALPC-D515B-3

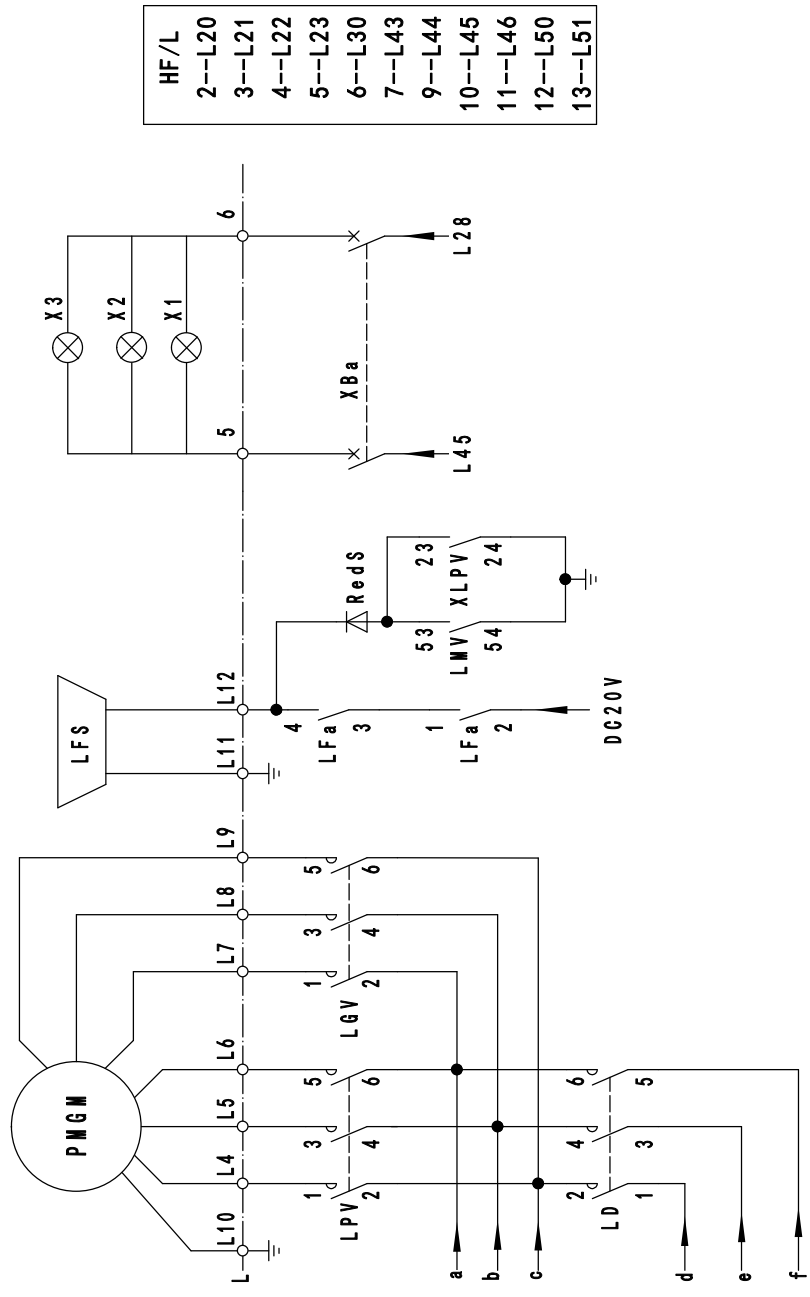

| HF/L |
|---------|
| 2--L20 |
| 3--L21 |
| 4--L22 |
| 5--L23 |
| 6--L30 |
| 7--L43 |
| 9--L44 |
| 10--L45 |
| 11--L46 |
| 12--L50 |
| 13--L51 |

| | |
|-----|-----|
| 108 | 109 |
|-----|-----|

ALPC-D515B-4

LAYOUT OF HOIST/SUPPLY POWER

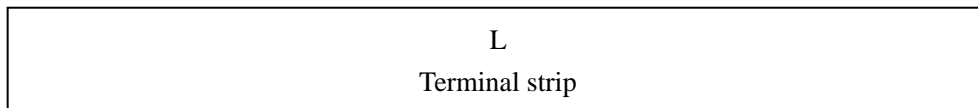
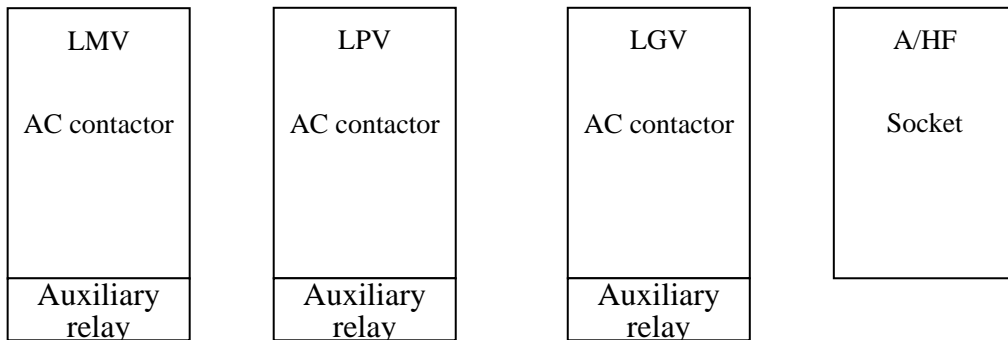
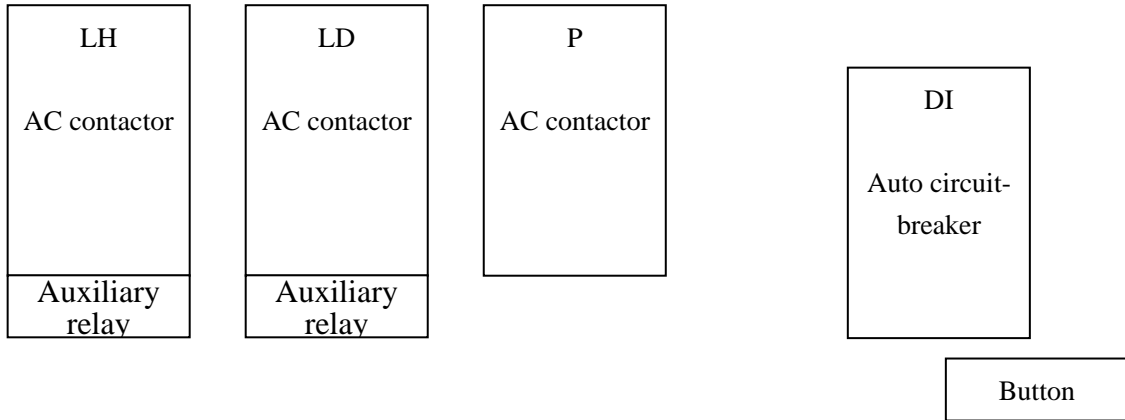
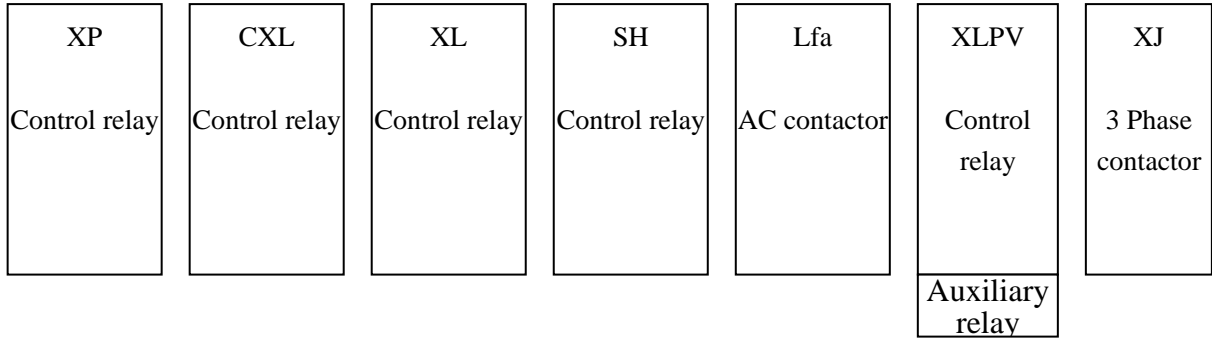
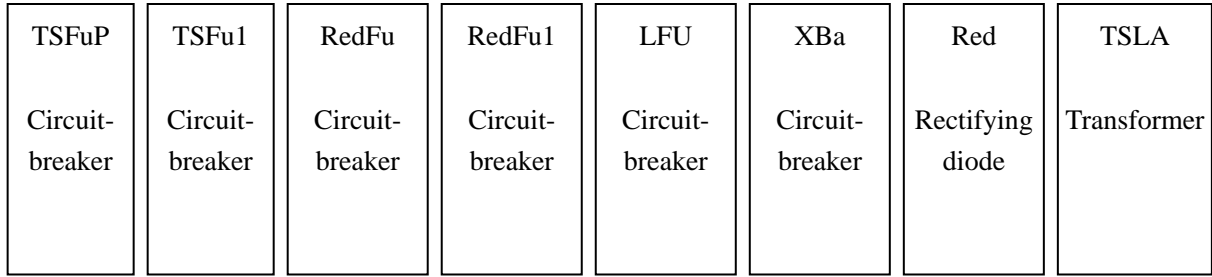

ELECTRIC PARTS LIST OF HOIST/SUPPLY POWER

| Symbol | Name | Q'ty |
|-----------------------------------|----------------------|------|
| TSLA | Transformer | 1 |
| DI | Auto circuit-breaker | 1 |
| TSFUP、TSFU1、RedFU1、RedFU、LFU、XBa | Circuit-breaker | 6 |
| Red | Rectifying diode | 2 |
| XJ | 3 Phase contactor | 1 |
| P、LH、LD、LMV、LPV、LGV、LFa | AC contactor | 7 |
| CXL、XP、XL、SH、XLPV | Control relay | 5 |
| Connecting XLPV、LPV、LD、LH、LGV、LMV | Auxiliary relay | 6 |
| L | Terminal strip | 44 |
| Au | Button | 1 |
| A/HF | Socket | 1 |

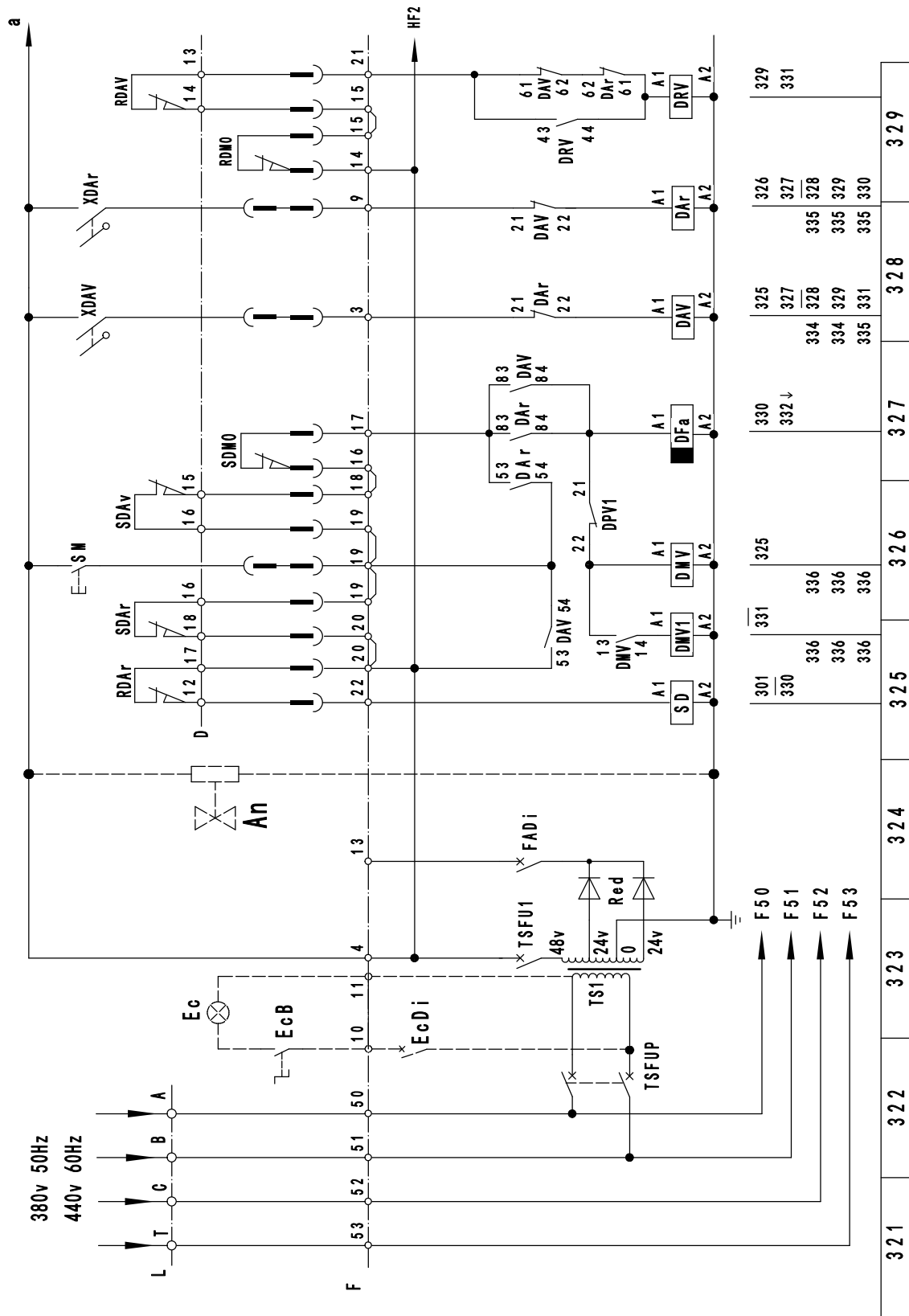

HF-D515G-1

| HF/R |
|--------|
| 1-H1 |
| 2-H2 |
| 3-H3 |
| 4-H4 |
| 5-H5 |
| 6-H6 |
| 7-H7 |
| 8-H8 |
| 9-H9 |
| 11-H11 |
| 12-H12 |
| 13-H13 |
| 14-H14 |
| 15-H15 |
| 16-H16 |

| HF/DRK |
|--------|
| 1-F1 |
| 2-F2 |
| 3-F3 |
| 4-F4 |
| 5-F5 |
| 6-F6 |
| 7-F9 |
| 8-F19 |
| 9-H34 |
| 10-H35 |
| 11-H37 |
| 12-H61 |
| 13-H43 |
| 14-H59 |
| 15-H36 |

| HF/L |
|---------|
| 2-H20 |
| 3-H21 |
| 4-H22 |
| 5-H23 |
| 6-H29 |
| 7-H43 |
| (8-H24) |
| 9-H44 |
| 10-H45 |
| 11-H46 |
| 12-H50 |
| 13-H51 |

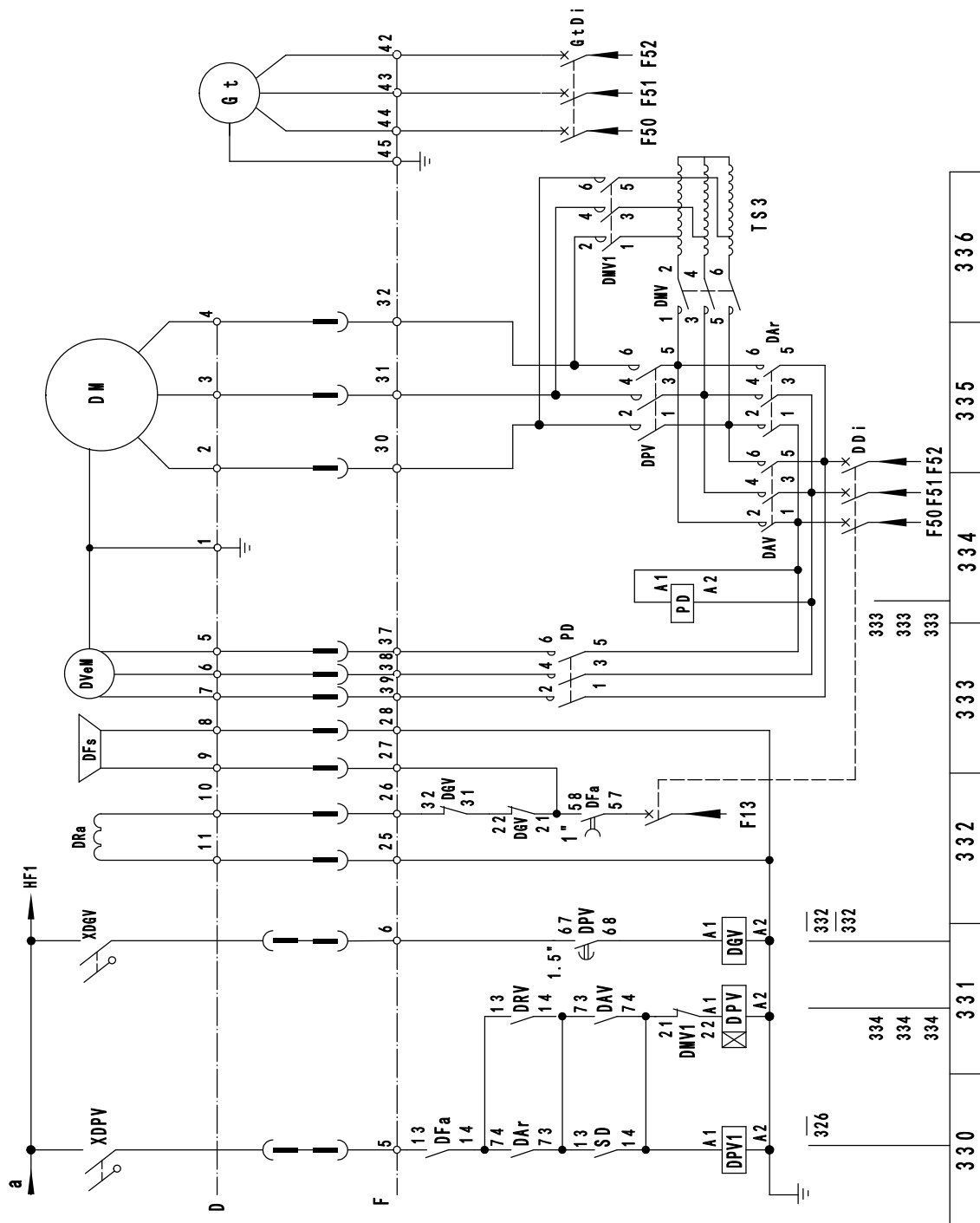

HF-D515G-2

| |
|--------|
| HF/D |
| 3-F25 |
| 4-F26 |
| 5-F27 |
| 6-F28 |
| 7-F30 |
| 8-F31 |
| 9-F32 |
| 10-F37 |
| 11-F38 |
| 12-F39 |
| 15-F15 |
| 18-F18 |
| 19-F19 |
| 20-F20 |
| 21-F21 |
| 22-F22 |

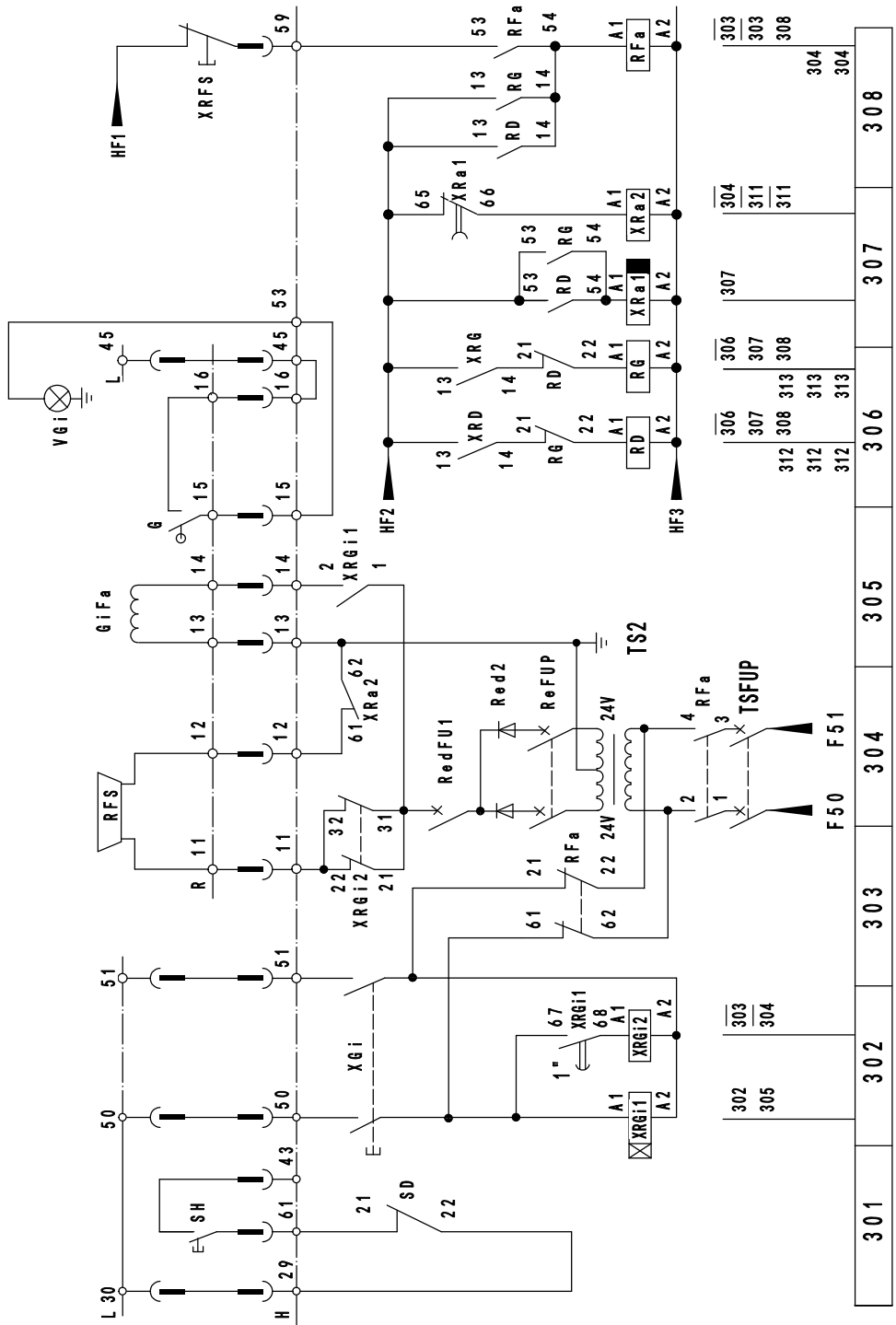

HF-D515G-3

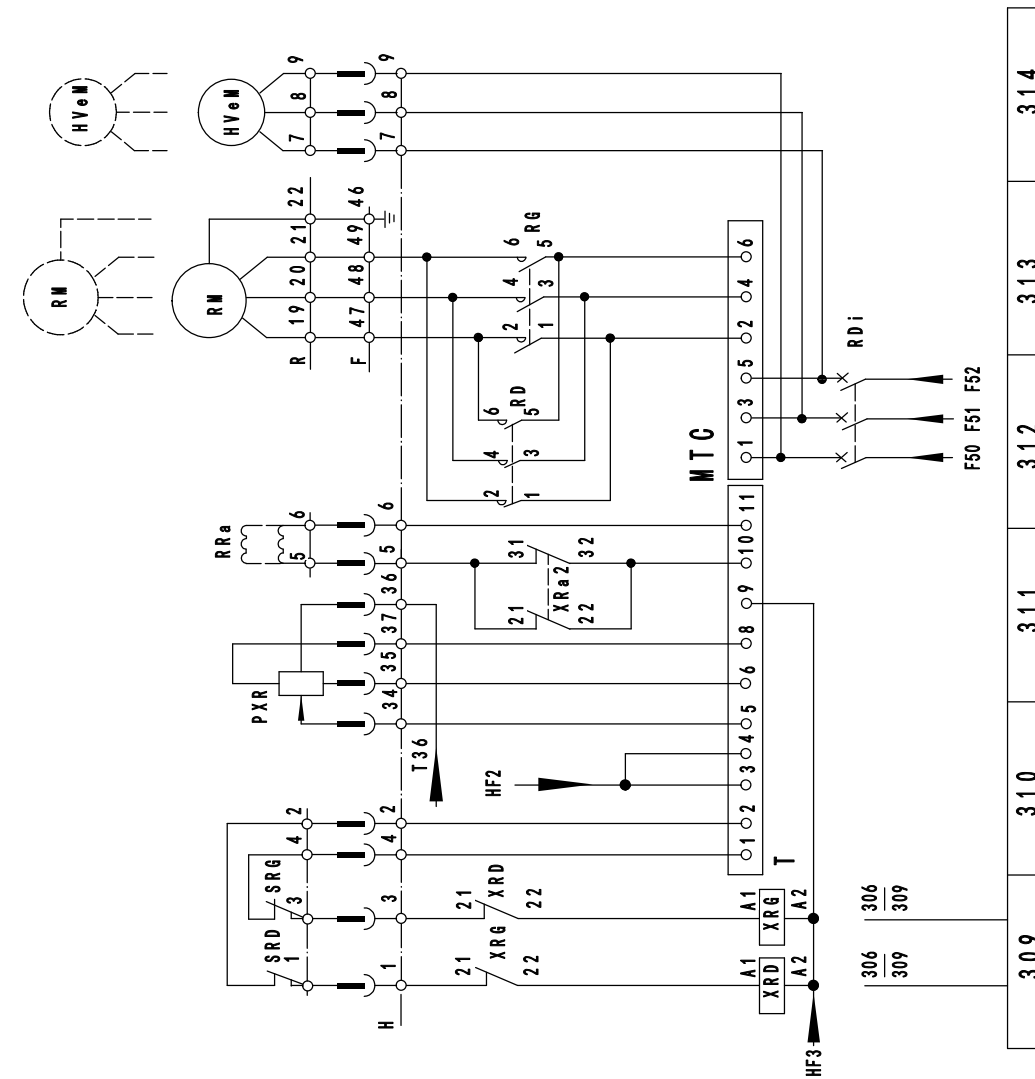
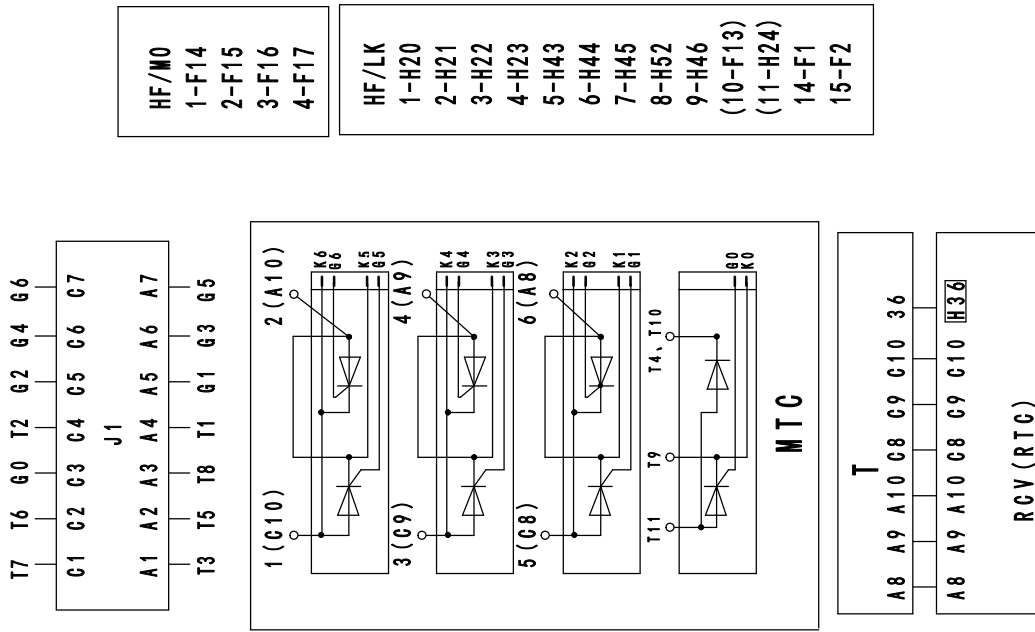

HF-D515G-4

LAYOUT OF SLEWING/TROLLEY

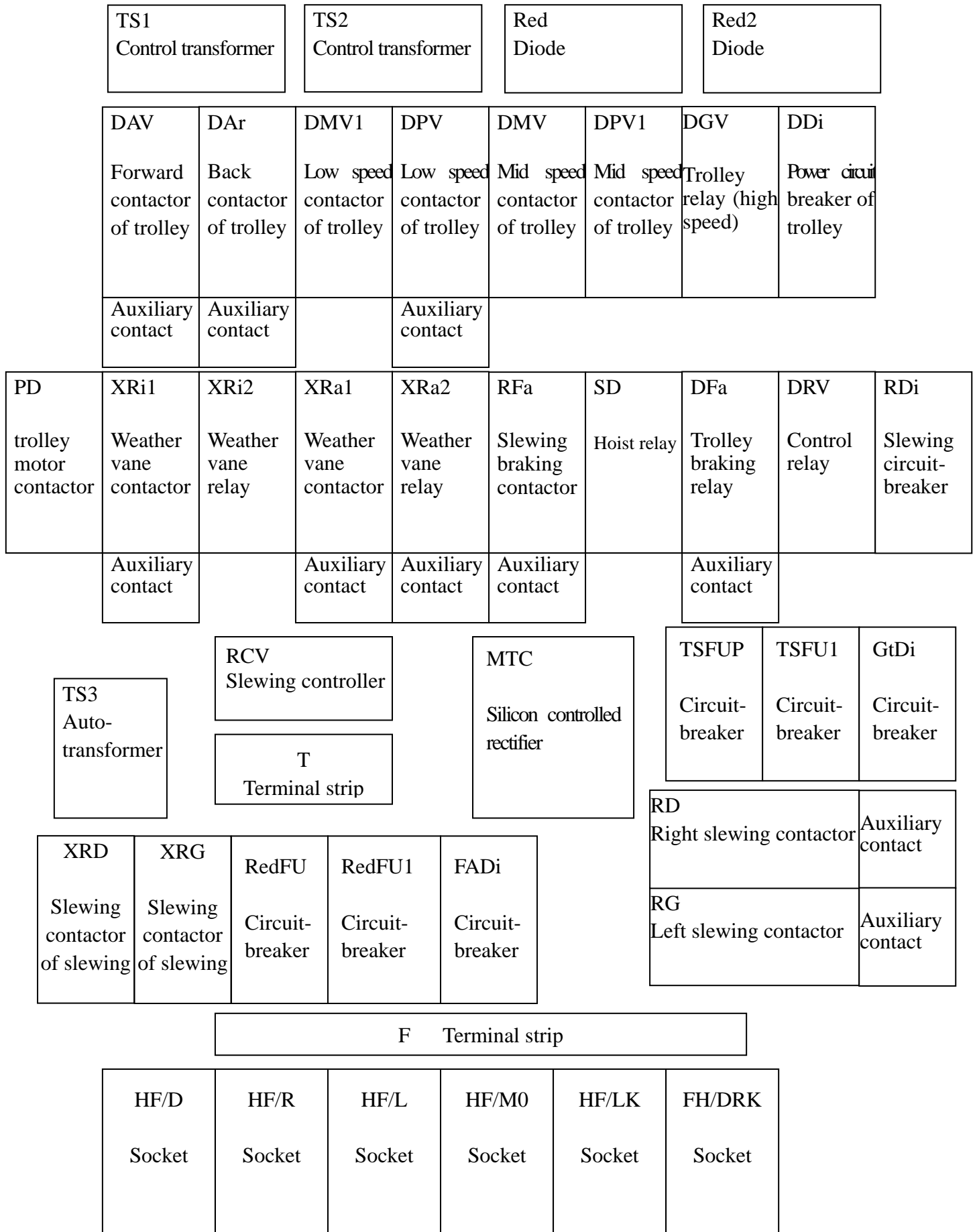

ELECTRIC PARTS LIST OF SLEWING/TROLLEY

| Symbol | Name | Q'ty |
|--|------------------------------|------|
| TS1 , TS2 , TS3 | Transformer | 3 |
| red , red2 | Rectifying diode | 2 |
| TsFUP , TsFU1 , RedFU , RedFU1 RDi , FADi , DDi , GtDi | Circuit-breaker | 8 |
| DAV , DAR , DPV , DMV1 , RD , RG , DMV , RFS , PD , XRI1 | AC contactor | 10 |
| SD , DGV , DPV1 , DFA , XRI2 , XRA1 , XRA2 , XRD , XRG, DRV | Control relay | 10 |
| RFS , DAV , DAR , Dfa , XRI1 , DPV RD , RG , XRA1 , XRA2 | Auxiliary contact | 10 |
| RCV | Slewing controller | 1 |
| MTC | Silicon controlled rectifier | 4 |
| H , F | Terminal strip | 107 |
| VGI | Weather vane Light | 1 |
| XRI | Weather vane Button | 1 |
| HF/L , HF/R , HF/D , HF/LK , HF/DRK , HF/M0 | Socket | 6 |

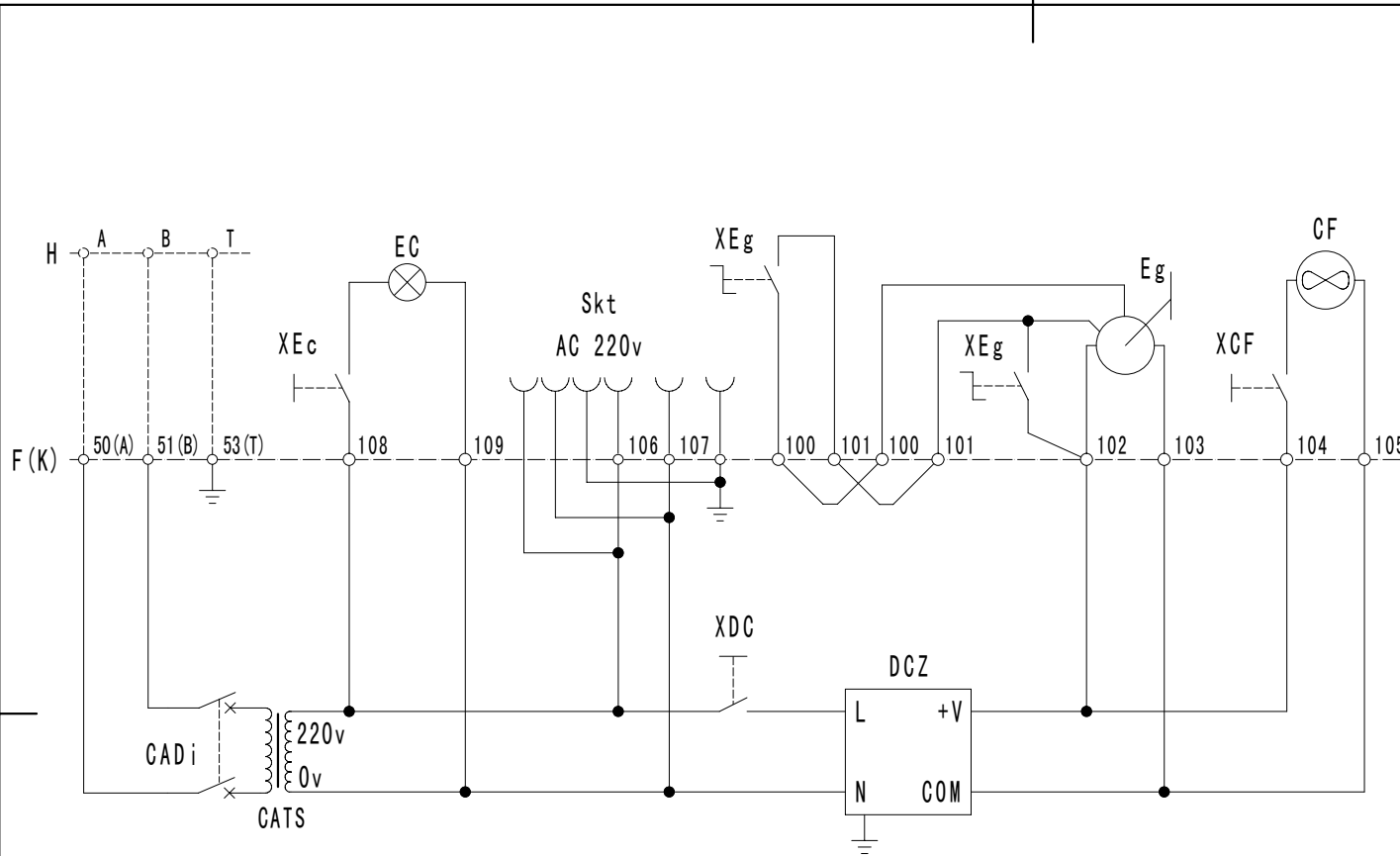

- CADi: 变压器断路器
Safety Transformer Circuit Breaker
- CATS: 变压器
Safety Transformer
- XEc: 司机室灯开关
Control Cab Lighting
- Ec: 司机室灯
Cab Lighting
- XEg: 雨刷器开关
Control Windscreen Wipe
- Eg: 雨刷器
Windscreen Wipe
- Skt: 插座
Socket
- XCF: 风扇开关
Control Fan
- CF: 风扇
Fan
- XDC: 直流电源开关
Control DC Power Supply
- DCZ: 直流电源
DC Power Supply

| | | | | | |
|------------|----------|------|------|--------------|--|
| | | | | | |
| | | | | | |
| | | | | | |
| IND NUMBER | DOC. NO. | SIGN | DATE | | |
| DESIGN | | | | | |
| | | | | | |
| | | | DATE | 2007. 07. 09 | |

**WIRING DIAGRAM OF
THE CAB**

CAB-D333C

| | | |
|--------------|--------|-------|
| DRAWING MARK | WEIGHT | SCALE |
|--------------|--------|-------|

Page of

YONGMAO

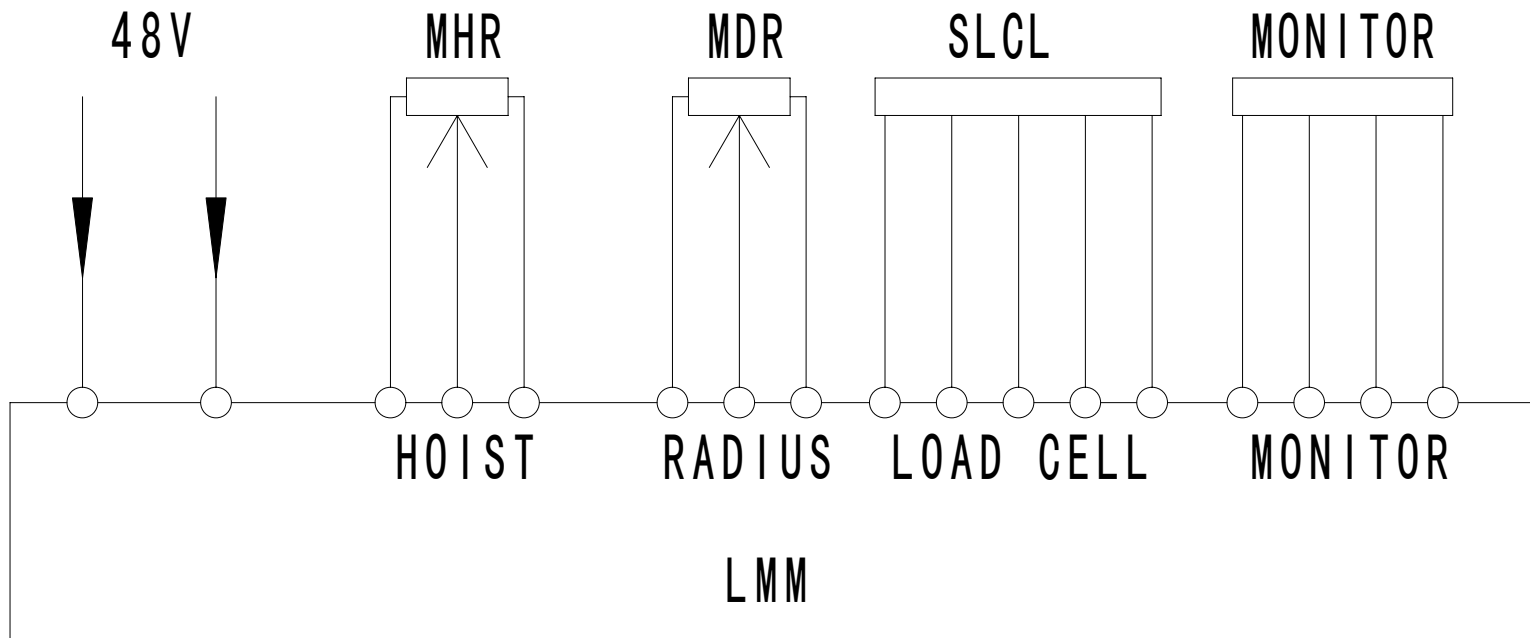

| | | | | |
|------------|----------|------|--------|--|
| | | | | |
| | | | | |
| | | | | |
| IND NUMBER | DOC. NO. | SIGN | DATE | |
| DESIGN | | | | |
| | | | | |
| | | DATE | 060629 | |

DISPLAY WIRING DIAGRAM

LOAD-D333A

| | | |
|--------------|--------|-------|
| DRAWING MARK | WEIGHT | SCALE |
| | | |

Page of

YONGMAO

Chapter VIII Safety device

| | |
|--|-------|
| I. Introduction | 8B-2 |
| II. Hoisting limiter | 8B-3 |
| 1. Purpose | 8B-3 |
| 2. Working principle | 8B-3 |
| 3. Adjustment | 8B-4 |
| III. Slewing limiter | 8B-5 |
| 1. Purpose | 8B-5 |
| 2. Working principle | 8B-5 |
| 3. Adjustment | 8B-6 |
| IV. Trolley limiter | 8B-7 |
| 1. Purpose | 8B-7 |
| 2. Working principle | 8B-7 |
| 3. Adjustment | 8B-8 |
| V. Moment limiter | 8B-9 |
| 1. Purpose | 8B-9 |
| 2. Working principle | 8B-10 |
| 3. Adjustment | 8B-11 |
| VI. Load Limiter | 8B-13 |
| 1. Purpose | 8B-13 |
| 2. Working principle | 8B-13 |
| 3. Adjustment | 8B-13 |
| VII. Anemoscope | 8B-16 |
| 1. Purpose | 8B-16 |
| 2. Main technical characteristic | 8B-16 |
| 3. Structure instruction and its working principle | 8B-16 |
| 4. Service and Maintenance | 8B-17 |

I. Introduction

The safety devices of tower crane are important devices which can ensure the safety of person and equipment.

Among the safety devices, the moment limiting device and load limiting device set a guard line for protecting the crane from overturning and rope broken. Once they are well adjusted, don't change them at random. The limit switch for each mechanism is to limit the motion range of them. The safety devices are important objects of supervision for the driver and maintenance personnel.

Note:

- ① If the top of tower crane exceeds 30m, it is necessary to install red obstacle indicator lights on the top of strut, jib nose and counter-jib nose, which remain current feed even the tower crane stopped.
- ②. If the joint height of jib foot exceeds 50m, it is necessary to install an anemoscope, which can send out alarm signal to stop operating the tower crane when wind speed exceeds maximum working speed.

II. Hoisting limiter

1. Purpose

Hoisting limiter is a device which can avoid any possible operation error.

- a). Stop hoisting motion when the hook block is 1-2m apart from the trolley.
- b). When lowering the hook block, prevent the wire rope from completely unwinding or winding up in reverse direction onto the drum.

2. Working principle

The limit switch, equipped with a reduction gear and located on the chassis of drum, is driven either directly by the drum shaft or through a pinion meshing a toothed ring. It drives several cams that control the circuit breakers, so as to cut off the corresponding motion.

Note:

Each time when transferring to a new site and before putting the tower crane into service, it is ESSENTIAL to unscrew the plug located at the lowest part of the limit switch in order to eliminate the condensation water. This plug must be re-placed before crane transportation.

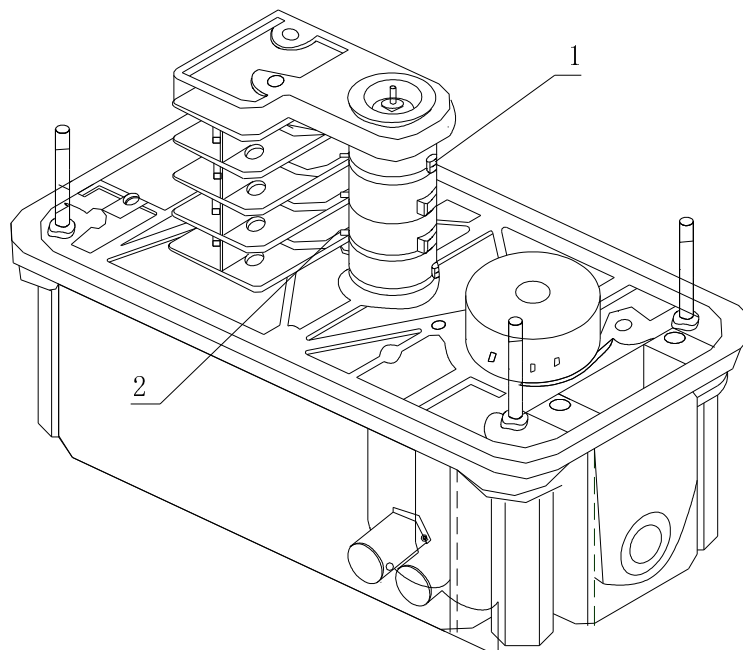

Fig. 8-2-1

3. Adjustment

After the tower crane reaches the expected working height:

Adjustment must be carried out with no load. Hoisting or lowering the hook, and operate the contact A or D manually, so as to confirm the contact which cutting off the controlling motion.

If changing height or fall of the tower crane, it is necessary to readjust the hoisting limiter.

1) Adjusting hoist limit switch for moving up (SLH)

Hoist the hook with 2-fall (or 4-fall) until a distance of only 1m remains between trolley and pulley block. Turn cam (4) by means of corresponding adjusting screw and check hoist control until it depresses the corresponding contact D so as to stop hoisting. (See Fig. 8-2-2).

2) Adjusting hoist limit switch for moving down (SLD)

This is carried out with 2-fall (or 4-fall). Turn cam (1) by means of corresponding adjusting screw so that it depresses the corresponding contact A. Here the hook stops before reaching the ground (it is forbidden to allow the hook touches the ground, to prevent the rope on the drum from coming off) and at least 3 layers of rope windings should remain on the drum when the hook is at the lowest position. (See Fig. 8-2-3).

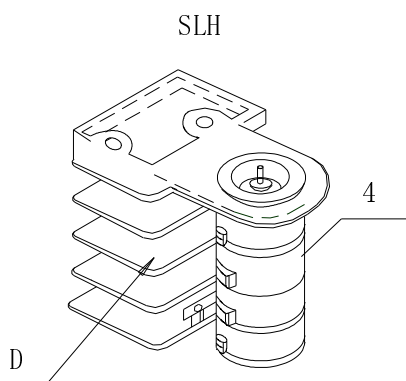

Fig. 8-2-2

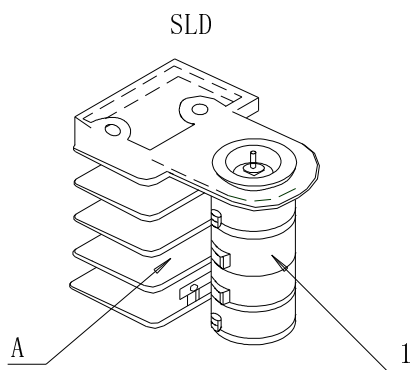

Fig. 8-2-3

Note: After erection or changing falls, it is necessary to readjust the hoisting limiter.

III. Slewing limiter

1. Purpose

This device is used for tower crane which without collector. It can prevent the electric cables from twisting and damage. When installed the slewing limiter, the max. slewing circle is 3.

2. Working principle

The limiter is with reduction gear which driven by a pinion, the pinion engaged directly with the slewing ring. When the crane slewing, this reduction gear drives cams 4 and 6 rotating, which controlled the circuit-breaker (sensitive switch), thus cutting off the slewing motion in suitable position via adjustment, (See Fig. 8-3-1).

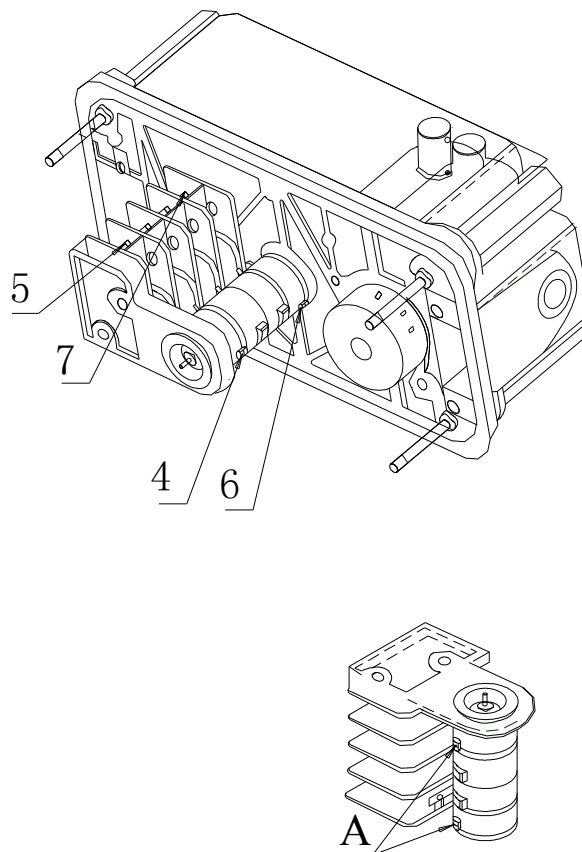

Fig. 8-3-1

3. Adjustment

Adjustment must be carried out with no load. Operate the “left slewing” or “right slewing”, and operate the contact A manually, so as to confirm the contact which cutting off the controlling motion.

- a). Adjusting the right slewing limiter (SRD): Slewing the jib, it can prevent the electric cables from twisting, make one and a half cycles slewing to the right, then adjust cam (4) and check up its motion, until it depresses the corresponding contact (5).
- b). Adjusting the left slewing limiter (SRG): Make three cycles slewing in the reverse direction. Then adjust the cam (6), until it depresses the contact (7).

Note: The above-mentioned adjustments should be checked everyday before the tower crane putting into service.

Each time when transferring the tower crane to a new site and before putting into service, it is essential to remove the plug which located at the lower part of limiter, and drain the condensation water in it. The plug must be installed before transferring to a new site.

IV. Trolley limiter

1. Purpose

The trolley limiter can prevent the operation error and keep a safety distance between the trolley and jib nose or jib foot.

2. Working principle

The trolley limiter is with a reduction gear, which is engaged with the gear ring on the drum via a pinion. This reduction gear drives cams (3, 6, 7 and 9) rotating, which controlled the circuit-breaker (sensitive switch 4, 5, 8 and 10), thus cutting off the corresponding motion, (See Fig. 8-4-1).

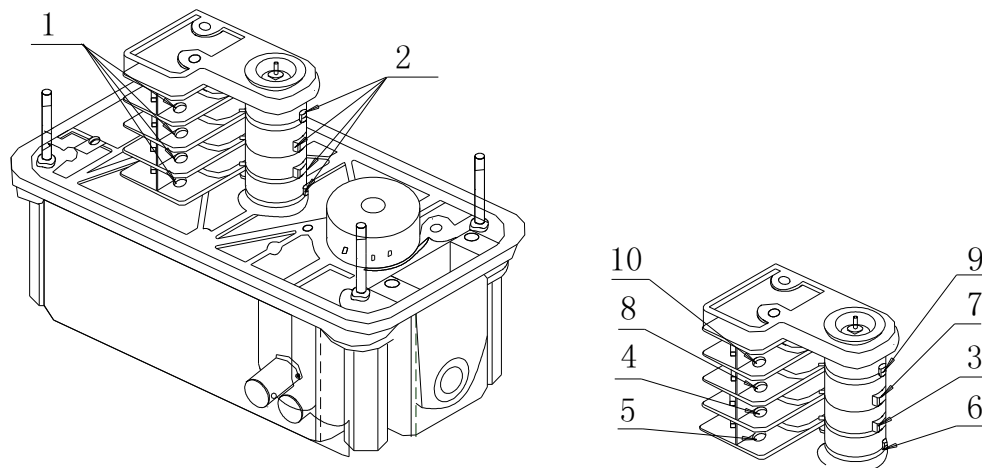

Fig. 8-4-1

3. Adjustment

- 1) Adjusting (trolley out and decelerate) safety device (RDA_v): drive the trolley to a distance of 1.5m from the jib nose buffer. Turn cam (3) until it depresses the corresponding contact (4).
- 2) Adjusting the trolley out limiter (SDA_v): drive the trolley to a distance about 20cm from the jib nose buffer. Turn cam (6) until it depresses the contact (5). Don't adjust the cam (3).
- 3) Adjusting (trolley in and decelerate) safety device (RDA_r) and the trolley in limiter (SDA_r) as above described, drive the trolley to the jib foot. Turn the cam (7) for decelerating, until it depresses the contact (8), and then adjust the limit cam (9), until it depresses the contact (10).

Note: The above-mentioned adjustments should be checked everyday before the tower crane putting into service.

V. Moment limiter

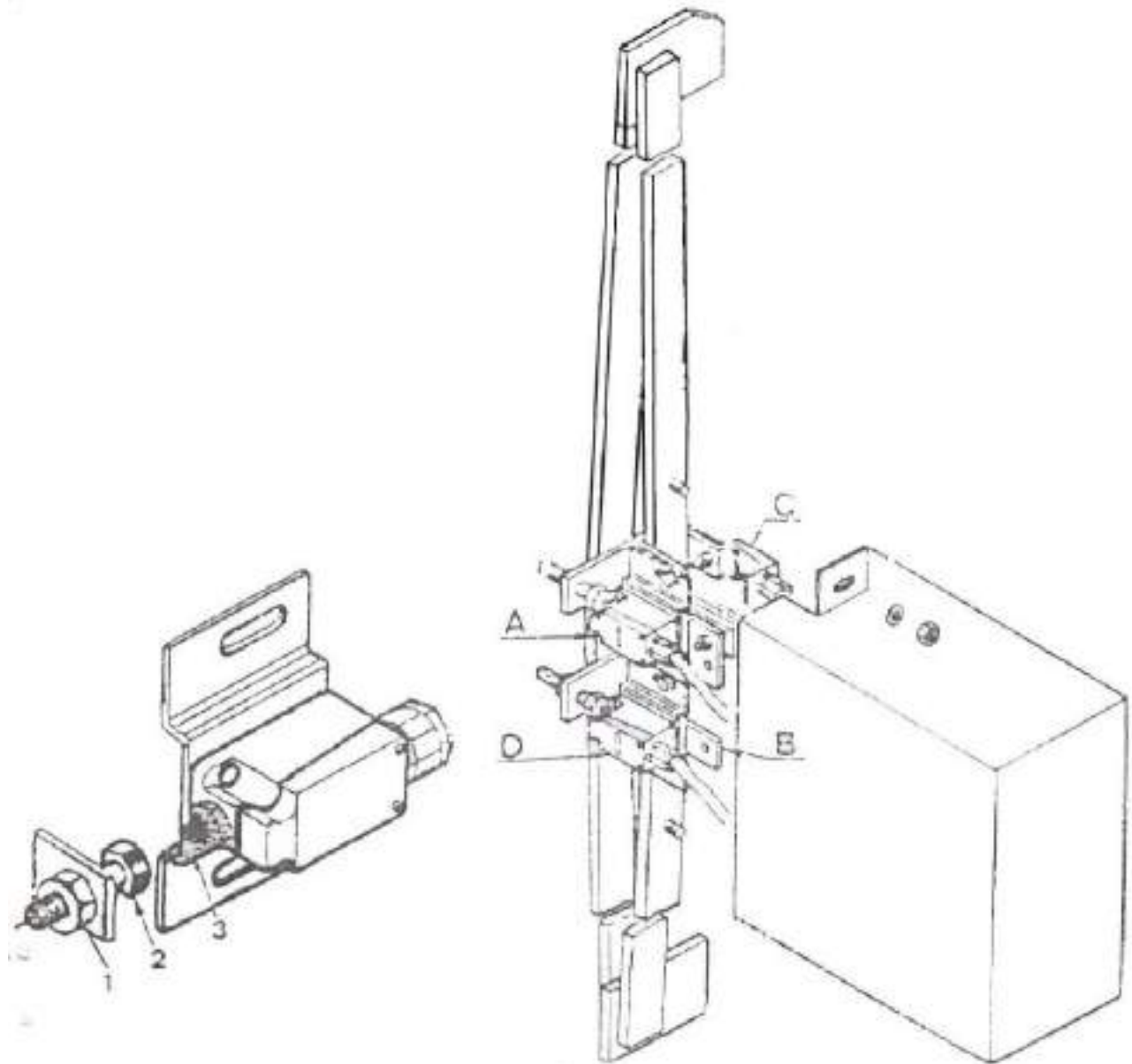

Fig. 8-5-1

The adjustment for device A, C and D

Loosen the nut (1), and turn the bolt (2) until it touches the contact (3) and pressing the switch contact. After accurate adjustment, lock nut (1).

1. Purpose

The tower crane is calculated and designed according to constant maximum load moment. During the operation, it is forbidden to exceed the load moment. The moment limiter is a device to inspect hoisting and trolleying motion so as to prevent the crane from accident on account of overload.

2. Working principle

The moment limiter, which is located on the cat head, consists of a pair of elastic plate, three micro-inching limit switches as well as installation support, adjustable screw, housing and so on. When hoisting a load, the elastic plate begins distorting (the distance between two amplifier bars reduced) due to the action of load moment. If the load exceeds the stated limit, the adjustable screw on one elastic plate depresses contact of limit switch located on the other elastic plate so as to cut off control circuit. So the mechanisms stop running to keep danger and damage away.

3. Adjustment

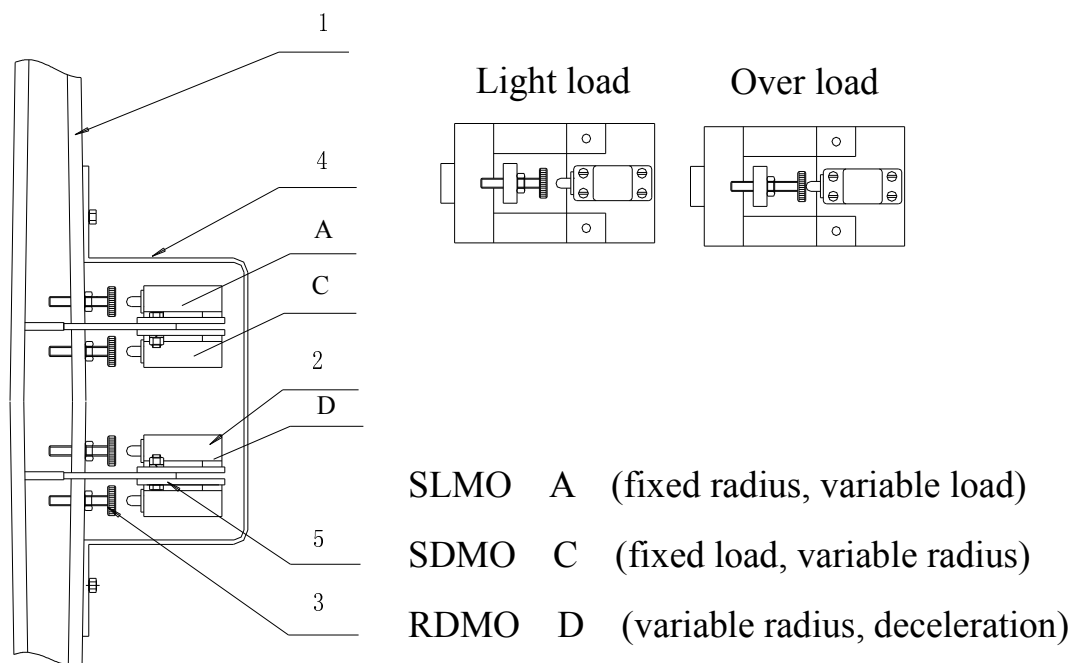

- | | | |
|-------------------|-----------------------------|--------------------|
| 1. Elastic plate | 2. Limit switch | 3. Adjusting bolts |
| 4. Moment housing | 5. Support for installation | |

Fig. 8-5-2

Table 8-5-1

| | |
|--|---|
| | <p>1. Adjusting the hoisting moment limiter SLMO</p> <ol style="list-style-type: none"> 1). Drive the trolley to the jib nose, and lift the specified load X with rated speed in 2 falls according to the jib length (adjust device A) 2). Lower the load, then lift a load of $Y=X+X \cdot 10\%$ with the lowest speed in 2 falls. The sensitive switch SLMO will motion and cut off the circuit, otherwise it should be readjusted. |
| | <p>2. Adjusting the trolley moment limiter SDMO</p> <ol style="list-style-type: none"> 1). Measure the distance and mark the valid radius (L) for max. load (W) and the radius $L'=L+L \cdot 10\%$ on the ground. 2). Lift the max. load (hang in the air) and drive the hook to the marked radius (L). (Adjust device C) 3). Drive the trolley to the jib foot, then trolley out with rated speed. Before reaching the marked (L'), the trolley motion should be cut off, otherwise readjust it. |
| | <p>3. Adjusting the moment limiter RDMO, which decelerate before reaching the max. trolley radius when trolley out.</p> <p>Lift the load X at the jib center, then trolley out with rated speed and adjust device D (see fig. 8-5-1), so that the trolley can running with low speed instead of rated speed as soon as reaching the radius D.</p> $D=0.8D_{MAX}$ |

Note:

- (a) The load X, W and radius L are selected according to the jib length and falls. (See table 8-6-3, 8-6-4).
- (b) Adjusting the device A, C and D: Unscrew the nuts and bolts, until the bolts can touch the contact of moment switch, but can not cause circuit break.

VI. Load limiter

1. Purpose

The structure and hoisting winch of the crane are calculated and designed in accordance with maximum load. It is not permitted that working load exceeds the maximum load. The load limiter **MSWL** is a safety device to prevent the crane from overload.

2. Working principle

When passing the pulley of the load limiter, the hoist wire rope produces tensile force due to action of load. The tensile force is transmitted to the load limiter, which connects with the pulley. As the load change, the load limiter begins distorting so as the steel plate on which inching switches (2,5) and adjustable screw (1,6) is fitted also distort accordingly (principle is the same as the moment limiter). According to the requirement of the load, by proper adjustment, the inching switch (2,5) is depressed as to control the circuit properly.

3. Adjustment

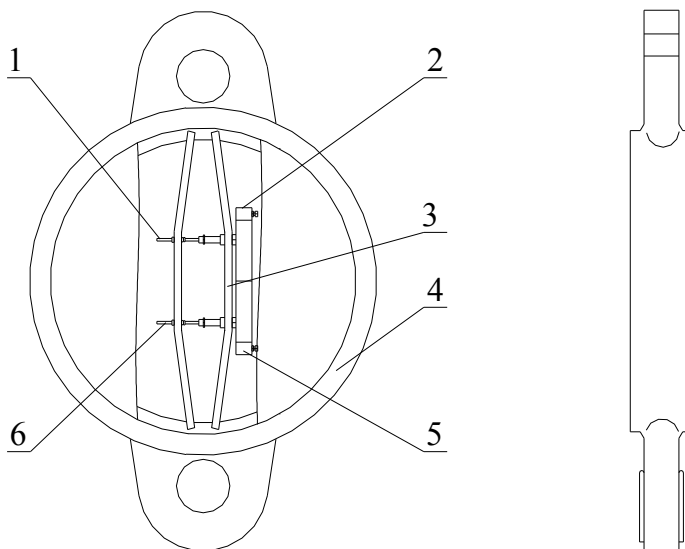

Fig. 8-6-1

1, 6 – adjusting bolt 4 – proving ring 2, 5 – sensitive switch 3 – metal strip

Note:

- 1) The tower crane should set 2 sensitive switches and adjusting bolts.
- 2) Except normal inspection and maintenance for the load limiter, after each erection and changing falls, it must be readjusted according to characteristic parameters.

Table 8-6-1

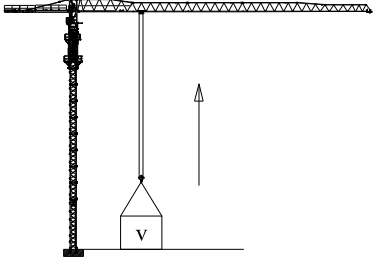
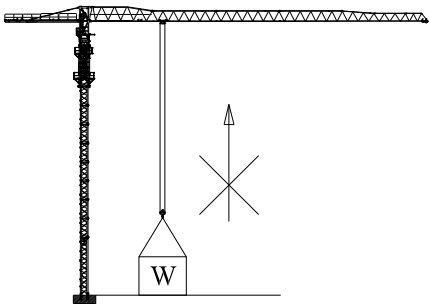
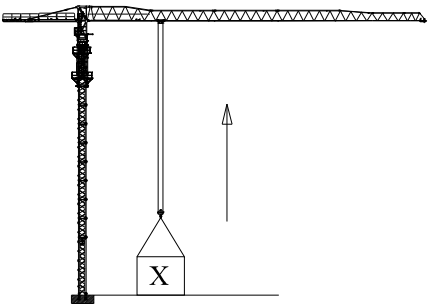
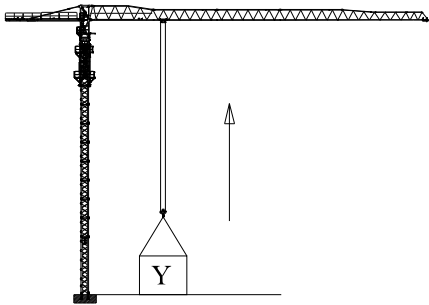
| Adjusting the speed limiter (SLCHGV) | |
|--|--|
| 1. Lift load V with low speed (PV), and then hoisting with high speed. |  |
| 2. Adjusting bolt (1) until the bolt head touches the sensitive switch (2). | |
| 3. Lower the load, and add 10% to the load. Lift it with low speed, then try to lift it with high speed. At this moment, it shouldn't obtain the high speed (the fifth gear), otherwise, readjusted. |  |
| Adjusting the max. load limiter (SLCHPV) | |
| 1. Lift load X with low speed. |  |
| 2. Adjusting bolt (3) until the bolt head touches the sensitive switch (4). | |
| 3. Lower the load, and add 10% to the load. Lift it with low speed. If the load can be lifted, readjusted it. |  |

Note: For various load V, W, X and Y, see the table 8-6-2.

Load table for max. working load limiter:

Table 8-6-2

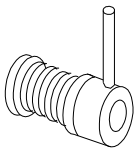
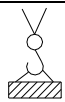
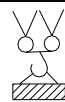
| | | | | | |
|---|---|---------|--------------------|---------|------|
|  | SLChGV | | SLChPV (MV) | | |
| | V (10N) | W (10N) | X (10N) | Y (10N) | |
| 24QPC15 |  | 1500 | 1650 | 3000 | 3300 |
| |  | 3000 | 3300 | 6000 | 6600 |

Adjusting load and radius table for the moment limiter

Table 8-6-3

| | | | | | | | |
|--|-----------|------------------------------|---------|-----------------------------|-------|--------|-------|
|  | 2-fall SM | Hoisting moment limiter SLMO | | Trolley moment limiter SDMO | | | |
| | L (m) | X (10N) | Y (10N) | W (10N) | L (m) | L' (m) | D (m) |
| | 52.5 | 1000 | 1100 | 3000 | 23.05 | 25.36 | 42 |
| | 50.0 | 1300 | 1430 | 3000 | 26.18 | 28.8 | 40 |
| | 47.5 | 1400 | 1540 | 3000 | 26.22 | 28.84 | 38 |
| | 45.0 | 1600 | 1760 | 3000 | 27.38 | 30.12 | 36 |
| | 42.5 | 1800 | 1980 | 3000 | 28.25 | 31.08 | 34 |
| | 40.0 | 1900 | 2090 | 3000 | 27.72 | 30.49 | 32 |
| | 37.5 | 2150 | 2365 | 3000 | 28.62 | 31.48 | 30 |
| | 35.0 | 2350 | 2585 | 3000 | 28.67 | 31.54 | 28 |
| 30.0 | 3000 | 3300 | 3000 | 30 | 30 | 24 | |

Table 8-6-4

| | | | | | | | |
|---|-----------|------------------------------|---------|-----------------------------|-------|--------|-------|
|  | 4-fall DM | Hoisting moment limiter SLMO | | Trolley moment limiter SDMO | | | |
| | L (m) | X (10N) | Y (10N) | W (10N) | L (m) | L' (m) | D (m) |
| | 52.5 | 950 | 1045 | 6000 | 12.76 | 14.04 | 42 |
| | 50.0 | 1250 | 1375 | 6000 | 14.43 | 15.87 | 40 |
| | 47.5 | 1350 | 1485 | 6000 | 14.45 | 15.90 | 38 |
| | 45.0 | 1550 | 1705 | 6000 | 15.06 | 16.57 | 36 |
| | 42.5 | 1750 | 1925 | 6000 | 15.53 | 17.08 | 34 |
| | 40.0 | 1850 | 2035 | 6000 | 15.24 | 16.76 | 32 |
| | 37.5 | 2100 | 2310 | 6000 | 15.72 | 17.29 | 30 |
| | 35.0 | 2300 | 2530 | 6000 | 15.75 | 17.33 | 28 |
| 30.0 | 3100 | 3410 | 6000 | 17.12 | 18.83 | 24 | |

VII. ANEMOSCOPE

1. Technical specifications

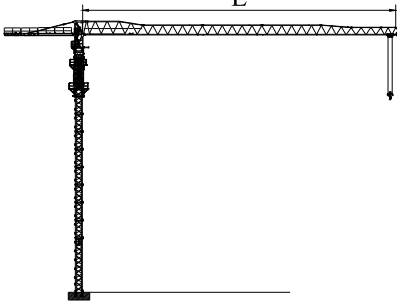
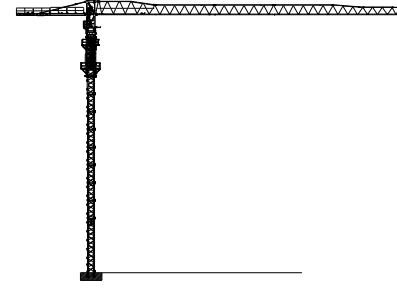
1.1 Power source: 48VAc/50Hz;

1.2 starting wind speed ≤ 1.5 m/s;

1.3 display $\leq \pm 3\%$;

2. Site humidity ranges

2.1 wind speed detector: -40 to $+50$ °C ; 0 to 100%RH

2.2 display: -20 to $+50$ °C ; 0-70%RH.

3. Operation principals and instructions for use

3.1 Operation principals

The wind sensor and the display are powered by three power cables. When the wind sensor sends out a pulse proportionate to the wind speed, the pulse is rearranged by the electric circuit board into DC electricity. Then the current is magnified and fed into the display to show the wind speed. A dedicated circuit board, processes the signal, which then powers 201 LEDs. The alarm sounds when the wind speed reaches the limit.

3.2 Instructions for use

Before applying electricity, connect the sensor with the display using the included power cable. Screw tightly. When electricity is applied, you can instantly read the wind speed and magnitude. The display has ft/s and m/s readings. green, the operating zone; yellow, the caution zone; and red, the danger zone. When the crane is rising, set the limit to 20. When the wind speed exceeds the above limits, an alarm will be set and the relay will cut the power. When the wind speed is back under the limit, operation can resume as normal.

4. Tuning and repair

4.1 The electrical circuit inside the wind display has already been adjusted, so there is no need for further tuning. In the event of sufficient depreciation and /or rough transport conditions, the display can be inaccurate, or the preset limit can be biased. In this case, a specialist can open the box and adjust the corresponding potentiometer;

Each potentiometer has the following purposes:

W1--13m/s limit alarm setup;

W2--20m/s limit alarm setup;

W3—LED bar full capacity adjustment;

W4—wide-angled needle display full capacity adjustment;

W5—test signal magnitude adjustment;

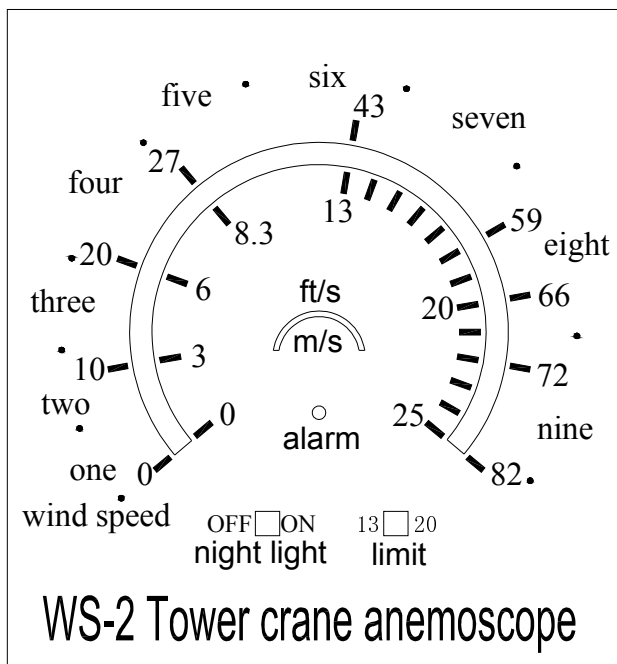

Signal display

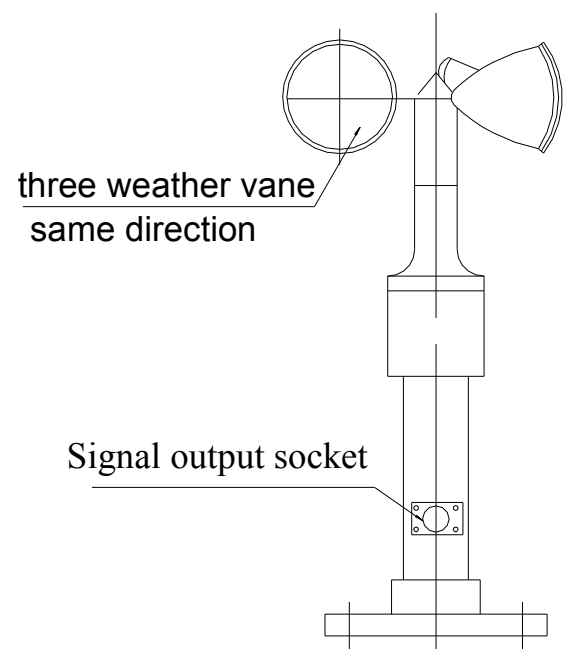

wind sensor

Chapter IX Hydraulic system

| | |
|--|------|
| I. Composition of hydraulic pump station | 9B-2 |
| II. Basic technical parameter..... | 9B-3 |
| III. Working principle..... | 9B-4 |
| IV. Operating and maintenance..... | 9B-6 |
| V. The common failure reason and its clearance | 9B-8 |

The hydraulic system of ST series tower crane is composed of: hydraulic pump station, telescoping cylinder, joining hose and so on.

I. Composition of hydraulic pump station

It mainly makes up of oil box, filter, motor, oil pump, combination reversing valve, pressure limiting valve and pressure gauge.

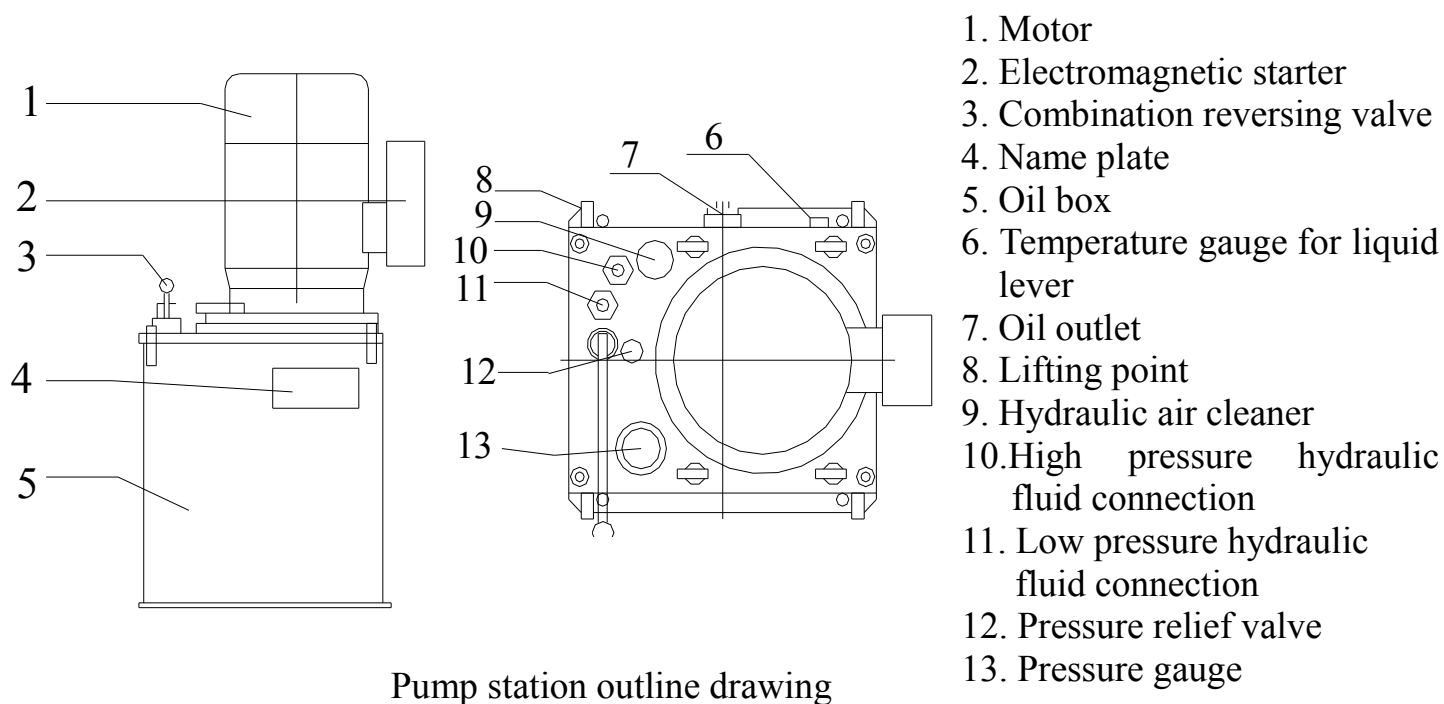

Pump station outline drawing

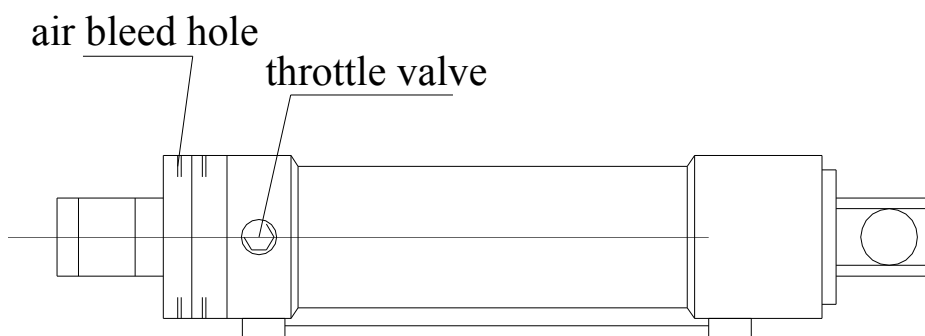

Outline drawing for telescoping cylinder

II. Basic technical parameter

| | |
|---------------------------------------|---|
| Hydraulic oil | N46 antiwear hydraulic oil or 40thickened oil |
| volume for oil box | 85L |
| Motor power | 4KW |
| Max. working pressure for telescoping | 20MPa |
| Oil pump capacity | 8.4L/mm |
| Cylinder inner diameter | Φ 160mm |
| Piston rod diameter | Φ 110mm |
| Max. telescoping force | 40.2t |
| Telescoping speed | 0.42 m/min |
| Return speed | Adjustable in safe range |
| Hydraulic travel | 1600mm |
| High pressure hose | West Germany standard:40-13-60 |
| H type high pressure hose assembly | 4m |

III. Working principle

Driving the oil pump by joint slack after motor starting, then the oil pump makes fat liquor from oil box to telescoping cylinder pass through the filter, combine change valve and high pressure glue pipe assembly.

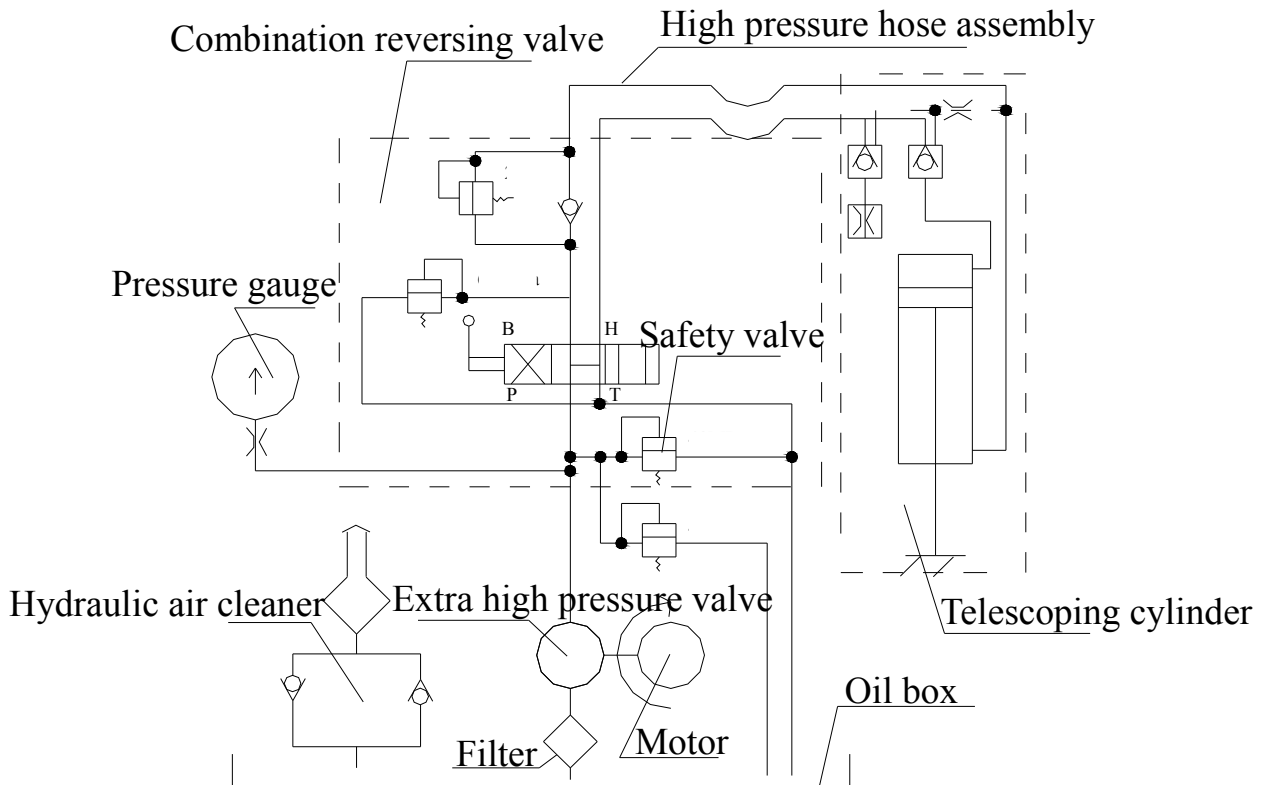

Hydraulic principle for telescoping system

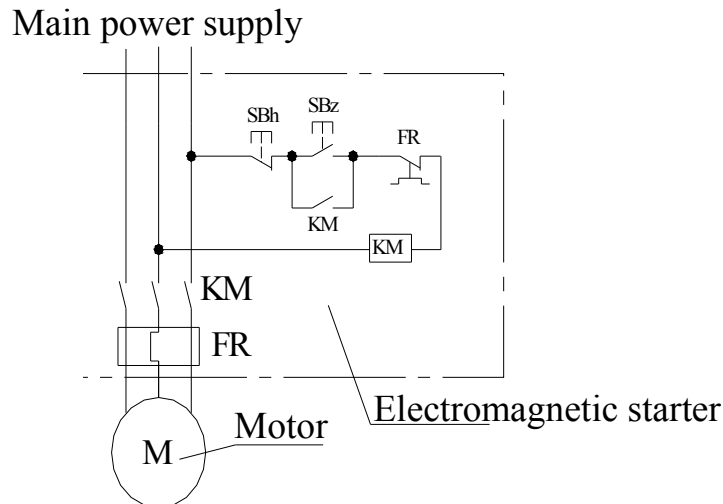

Electrical principle for pump station

The combine change valve in the middle position **H**, the opening **P** and opening **T** are joined, the output hydraulic oil of the oil pump went back, the hydraulic system in unload condition at that moment.

Combine change valve in the left position of dig.(when lift the combine change valve's handle), the output hydraulic oil of oil pump come into the big chamber pass through the combine change valve **P** and **H**, the high pressure glue pipe assembly and bidirectional hydraulic lock. Opening the bidirectional hydraulic lock at same time and make piston of cylinder downward movement; the hydraulic oil of the cylinder's small chamber reflow via the bidirectional hydraulic lock, high pressure glue pipe assembly, combine change valve **B** and **T**, the telescoping cylinder start raise work. The flow quantity of cylinder confirms the raise speed.

Combine change valve in the right position of dig.(when press the combine change valve's handle), the output hydraulic oil of oil pump come into the small chamber pass through the combine change valve **P** and **B**, the high pressure glue pipe assembly and bidirectional hydraulic lock. Opening the bidirectional hydraulic lock at same time and make piston of cylinder upwards movement; the hydraulic oil of the cylinder's big chamber reflow via the bidirectional hydraulic lock, high pressure glue pipe assembly, combine change valve **H** and **T**, the telescoping cylinder start down work. Adjustment of the restrictive valve of cylinders confirms the down speed.

IV. Operating and maintenance

1. Connect the motor's main power supply exactly; make the motor wheeling comply with counter-clockwise (check the motor's turning by point movement method) observed from shaft extent direction. Open the cover of the hydraulic air filter and fill the clean and appointed hydraulic oil from it; connect the hydraulic telescoping system pipeline according to the hydraulic system elementary diagram and screw down the joint; test run and notice the hydraulic pump station whether in normal work condition. The cylinder maybe jogging at beginning, here need to turn left the airbleed screw at air bleed hole of cylinder and spurt some oil. Operate it several time, if it didn't jogging please tighten up the airbleed screw rightward; check the telescoping flooding valve pressure,(adjustment of telescoping flooding valve is 40Mpa before leave the factory, have no need to adjust in service. But you can adjust demand pressure depend on need, adjustment of the down flooding valve is 6.5Mpa) namely be observed the pressure when the cylinder overhanging completely and after it recovery completely. Finished the above work can put into normal work.

2. Although top up the oil at first time, it reduce and from oil box to the cylinder when it starting, so should supply the hydraulic oil up to the liquidometer upper limit when the hydraulic telescoping system bringing into service. Check the hydraulic oil's cleanliness termly, general condition, should make check once six month or after 2000 hours. According to specific circumstances, it can also check the oiliness ahead of time. If the oil is bring and clean use it continue, if the oil is solidification and feculence please replacing new oil; In order to protect the seal ring of cylinder should often wipe dunghill on piston rod The hydraulic pump station should be covered with plastic material after complete work. To protect the water pollute the oilness and prolong the useful life.

3. Observe whether the oil is curdle if the hydraulic system disuse long time. Hydraulic system is made contact and operated period of time (no load) each two or three months. The cylinder and pump are proceeding the hydraulic cycle to filled oils with its surface to have no rust and protect pump, valve and cylinder.

4. The hydraulic oils must be replacing in time when it have milkiness, freezing and feculence phenomenon. The cylinder will be cleared and checked some place whether have rusted when replaced the oils. When occurred above phenomenon must be complete deal before refill oil and operate.

The important never adjusting the throttle valve during having load, otherwise it is very dangerous to do so.

V. The common failure reason and its clearance

1) The cylinder shakes heavily when it lowering. The mast will swinging if it shakes badly.

Reason: The adjustment of throttle valve for oil return circuit is unsuitable.

Eliminate method: Adjust the throttle valve according to the instruction manual, until it reaches to the optimum condition. If the opening position of throttle valve for cylinder didn't align with the screw thread, it can not be adjusted.

2) The joint sleeve damage

Reason: The manufacturing engineering of sleeve wasn't ensured.

Eliminate method: Replace the joint or weld, i.e. weld the nut and direct connection hard. (At this time, the joint can't adjust the direction of oil pipe).

3) The cylinder continually falling down

Reason: Two chambers of the cylinder have residual gas left; not well sealed; or the hydraulic oil wasn't clear.

Eliminate method: Eliminate the gas from the cylinder; ensure the seal of control piston and one-way valve; often check the oil cleanliness and ensure the oil box well sealed; the control valve in hydraulic pump station must be accurately adjusted.

※The interface for high and low pressure of hydraulic telescoping system cannot be overturned; it is forbidden to adjust throttle valve when the cylinder was with load; it must be careful to adjust the high pressure throttle valve.

CHAPTER X FIXING AND TESTING RULES FOR WIRE ROPE

| | |
|---|--------|
| I. Explanation | 10B-2 |
| II. Fitting wire rope | 10B-2 |
| 1. Fitting new wire rope | 10B-2 |
| III. Maintenance | 10B-4 |
| IV. Inspection | |
| 1. Daily observation | 10B-4 |
| 2. Periodical inspection by person in charge | 10B-4 |
| V. Inspection Places | |
| 1. General Inspecting places | 10B-5 |
| 2. Inspecting places on drum | 10B-5 |
| 3. Checking places around crown block and fixed-points | 10B-6 |
| 4. Internal Checking on wire rope | 10B-7 |
| 5. Inspecting places at the end of wire rope | 10B-7 |
| VI. The discard as useless standard of rope | |
| 1. The quality and quantity of broken rope | 10B-8 |
| 2. Rope end broken wire | 10B-9 |
| 3. Broken wire part collection | 10B-9 |
| 4. Broken wire increase rate | 10B-9 |
| 5. Wire of rope breaking down | 10B-9 |
| 6. Rope diameter decrease due to the core of rope break down. ... | 10B-9 |
| 7. Flexibility decrease | 10B-10 |
| 8. Outside and inside attrition | 10B-10 |
| 9. Outside and inside corrosion | 10B-11 |
| 10. distortion | 10B-11 |
| 11. The vitiate resulting by heat or electric arc effect | 10B-11 |
| VII. Equipment condition for Relevant rope | 10B-12 |
| APPENDIX: COMMON WIRE ROPE DEFECTS | |

I . Description:

Although its structure is compact and its appearance is strong, the fatigues and wear of wire rope is unavoidable. The worn and aging wire rope will be damaged rapidly, which would result in severe accidents (both on person and equipment) if the users do not pay special attention to it. The change of the wire rope can be found by periodical inspection. For the hoist equipment, the wire rope should be taken as a kind of expendable. They should be changed as its intensity and strength reduces.

II . Fitting wire rope

The type and specification of new wire rope should be the same as the original one. If not, the user must ensure that the characteristics and the capability of new wire rope is not lower than the original one, and the new wire rope is applicable to the groove of drum and pulleys. Prevent wire rope from knotting, twisting together, and buckling or adhering sundries when drawing out the wire rope from scroll or wire rope roll. Before using the wire rope of the crane, the consumer should ensure that all kinds of the device involved with the work of wire rope are in order and run properly normally. In order to keep the wire rope in place steadily, operate the crane to hoist 10% of rated load for several times.

1. Fitting new wire rope

1) Completely unwind the rope on the clean ground, avoiding any twist (see **Fig. 10-2-1**). If it is not possible to lie out the whole rope completely, unwind it in large loops. In this way, dangers can be avoided from occurring when the wire rope is wound on the drum.

- 2) Check the length of wire rope .
- 3) Enwind the wire rope on the drum by means of a sling and fasten it with bulldog grips. The length of the wire rope's jut from the last bulldog grip is no less than **3cm** (the tightening moment of the screws of bulldog grip is **9 mdaN**).
- 4) Apply "Hoisting up" operation to enwind the rope on the drum for 4-10 circles .At the same time tension the rope properly.(**Fig. 10-2-2**).
- 5) Check adjustment of the limit switch and readjust it if necessary.

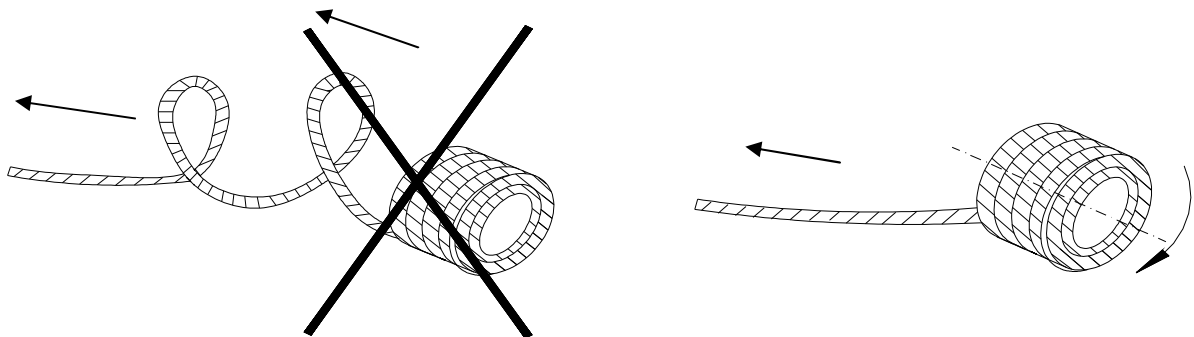

Fig. 10-2-1

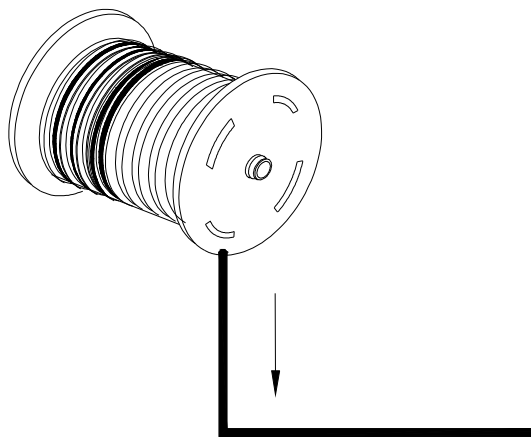

Fig. 10-2-2

III. Maintenance

Maintenance of wire rope depends on the purpose of tower crane, the working environment as well as the kind of wire rope used. If possible, the wire rope should be purged and oiled or greased (**except otherwise stipulated by the tower crane manufacturer or the wire rope factory**), especially the bended and curved part of the wire rope that reel through pulley. The kind and type of lubricating oil and grease should be suitable with that used in the wire rope factory. For the wire rope, the lack of maintenance is one of the primary reasons of short-life time, especially when the tower crane works in a caustic environment or the wire rope can not be greased due to some reasons caused by the limitation of the operation.

IV. Inspection

1. Daily observing

It is recommended to observe all the visible parts of the wire rope every working day so as to discover any damage or distortion in time. Pay special attention to the part which is fixed on the crane, if any obvious change is found, inform the person in charge to inspect it according to the fourth item listed below.

2. Periodical inspection by the person in charge

The following items should be taken into account in order to determine inspection period and inspection cycle.

- a. National statute for hoisting machinery, such as GB5144-2006 《Safety rules of**

tower crane» ;

- b.** Types of tower crane and its working environment;
- c.** Working level of tower crane;
- d.** The results of the tests before and the defects found.
- e.** Working time of the wire rope since its initial use.

**Ensure that the wire rope of the tower crane is inspected at least once a week.
After an accident or before putting into service again after dismantling,
inspect the wire rope thoroughly .**

V. Inspection places

1. General Inspecting places

Pay special attention to the following places although a thorough inspection on the whole length of the wire rope should also be made.

- a.** The places with rope running and two fixed ends of the rope.
- b.** The rope sections reeling through the pulley block. Pay special attention to all the places reeving through pulleys during the hoisting when the mechanism effect repeated operation.
- c.** The rope sections located in the balancing pulley.
- d.** The rope sections that can be worn due to external factors.
- e.** Internal inspection for caustic and fatigues. The inspection results should be recorded on the equipment inspection notebook.

2. Inspecting places on drum: (See Fig.10-5-1)

- a)** Check the terminal places of the wire rope on the drum.
- b)** Check for distortion and abrasion caused by unqualified winder, especially at the places with wire rope superposing and skipping.

- c). Check for broken rope.
- d). Check for erosion on the wire rope.
- e). Check for distortion caused by adding load suddenly.

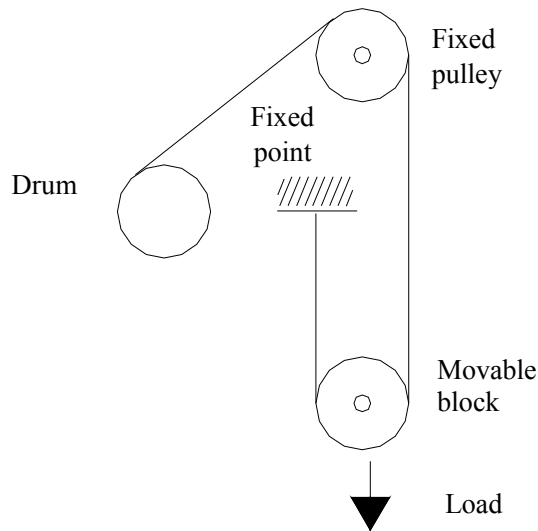

3. Checking places around crown block and fixing points:

- a) Check for damaged rope section and for abrasion section of wire rope which winding through pulleys
- b) Check for broken rope and for the erosions on the wire rope around its fixing points. The same inspection should be made on the rope section near the balancing pulley.
- c). Check for distortion of rope.
- d). Check the diameter of the wire rope.

Check places around traveling block

- a) Check carefully on the section passing through the traveling pulleys, especially the section around the pulleys while hoisting a load
- b) Check for broken rope and surface abrasion
- c). Check for erosion of rope.

4. Internal inspection of the wire rope

It draws a conclusion from the experience of inspection and discard as useless of wire rope that internal damage is mainly caused by the erosion and fatigues that is the primary reason of wire rope invalidation. Internal damage degrees might not be discovered by external inspection even if the wire rope is impending the danger of broken completely. The person in charge should carry out the internal inspection.



The method of inspection is as follows:

Firmly clamp wire rope by means of two clams in a certain distance, screw the clamp so that the outer layers of the rope are divorced from the core of wire rope. When the wire rope is untwisted slightly, clean out the grease and the bits in the rope by using a screwdriver so as to effect observation easily. The items to be inspected are as follows:

- A. Internal lubrication
- B. Degree of erosion.
- C. Steel wire impress due to extrusion and abrasion
- D. Confirm if there are broken rope, then restore it to its original state. Then grease on the surface. (This method will not be adopted on the wire rope with multiple layers).

5. Inspecting the ends of wire rope (except for riggings and slings)

It is very dangerous if the wire rope from fixing end is rotted, therefore this place should be inspected properly, the same inspection should be made on other fixing device such as rope anchor box that is made through forging or molten, and bulldog grips. Check if there is crackle; check for possible slide between rope anchor box, bulldog grip and wire rope; check fixing status of wire rope on the drum. In any case, the requirement that the wire rope on the drum not less than 3 circles should be observed strictly.

VI. The discard as useless standard of rope

1. The quality and quantity of broken rope

For six layers and eight layers of ropes, broken rope mostly occurs on the appearance. And that is difference to wire rope of multi wall wire of rope, broken rope of this wire rope occurs inside but not to view.

The visible broken ropes are related to the fatigue when the rope must be scrap in the hoisting machinery.

Table 10-6-1

| (n) the number of out layer rope load | rope construction | working grade for mechanism M3~M8 | | | |
|---|---------------------------------|-----------------------------------|-----|------------|-----|
| | | alternate lay | | albert lay | |
| | | extent | | | |
| | | 6d | 30d | 6d | 30d |
| 101~120 | 6x19、7x19、6x(19) 6w(19)、34x7 | 10 | 19 | 5 | 10 |
| 221~240 | 6x37 | 19 | 38 | 10 | 19 |

Notice: 1.The working grade of mechanism for tower crane is M4.

2.The diameter of wire rope d

3.Should take out the stuff steel wire from the check number because can't make stuff steel wire as load steel wire. The multilayer rope only consider visible out layer wire of rope, for the rope with the steelcored don't consider the rope core and look upon inside wire of rope.

2. Rope end broken wire

When the rope broken wire at rope end or round, it indicate this part have high stress even have a litter, maybe arose by rope end setting incorrect, should found out the reason for damage. And should cut off the part of broken then set it over again reasonably if its length allowed.

3. Broken wire part collection:

The rope should discard as useless if it broken wire forming part collection together and that broken wire gather length of rope range less than **6d** or it concentrate in discretionary wire of rope even if broken wire number less than the list shown.

4. Broken wire increase rate:

In some use occasion, fatigue is an important reason result in the rope's damage but the broken wire start occurs after using period and its number increase in short time. In this condition, should check and write down the broken wire increase condition in order to adjudicate it **increase rate. This rule could confirm the future date of rope discard as useless.**

5. Wire of rope breaking down:

The rope should discard as useless if the whole wire of rope breaking down.

6. Rope diameter decrease due to the core of rope break down.

The rope should discard as useless when the rope diameter decrease due to damage the fiber core and breaking off the steel core (or inner wire of rope for multistoried frame).

7. Flexibility decrease:

In some condition (generally relate to the working environment), the flexibility of rope shall decrease observably; it's not safe if use continue. Generally accompany follow phenomena:

a).The rope diameter minish:

b).Extending length of lay for rope

c).Shortage the air gap between rope and wire of rope due to every sections extruding each other.

d).There are imperceptible brown power appeared wire of rope scoop;

e).Although don't found the broken wire it's damage too fast. Because rope not easy to bent and the diameter decrease will damage badly than wear out the rope purely which will result in the rope break down suddenly under move load effect so should discard as useless immediately

8. Outside and inside attrition:

a).Inside **attrition and press delve:**

This phenomena caused by rubbing between every wire of rope and steel wire, in particular when the rope often stand the bent again and again.

b).Outside attrition

The attrition of steel wire surface for rope out layer wire of rope due to pulley and drum score contact and frection under pressure effect or the friction between ropes on the drum. Shortage lubrication or incorrect lubrication, exist dust and sand grain shall aggravate attrition. The rope should discard as useless when cover wire

attrition reach diameter 40% and even not found the broken fiber when the rope diameter decrease 7% or more relative to nominal diameter.

9. Outside and inside corrosion:

a).Outside corrosion:

The corrosion outside the rope can observe by naked eye. The rope should discard as useless when the surface appears chasm and rope quite loosens.

b).Inside corrosion:

Check up the inner of rope, the rope should discard as useless if it confirmed inner corrosion badly.

10. Distortion

The ropes lose the normal shape and produce the visible freak owing to mechanical damage or local fatigue in rope using, which can result in rope inner distributor of stress asymmetry, familiar there are: undulation, cage shape distortion(appear in multilayer enwind rope) steel wire force out, rope diameter local accretion, kinking, rope diameter local minish, part crushed and kink. The rope should discard as useless when appear above phenomena.

11. The vitiate resulting by heat or electric arc effect:

The surface of rope in annealed condition duo to the heat factor, the rope discard as useless on account of electrical are welding contact, broken wire and broken wing of rope.

VII. Equipment condition for Relevant rope

Should periodic check the enwind drum and pulley in order to make these parts well running on bearing. Dig or locked pulley or turn part arouse rapid aggregative wear out and uneven so result in the rope serious abrasion. All radiuses for pulley bottom of slot and nominal diameter of rope are on speaking terms. In order to assure the rope normal operation in pulley groove in any position and setting device prevent the rope escape from grooves.

Notice in particular

- **Forbid the rope after insert and joint use to the mechanical drive when it worn out.**
- **Don't allow the rope distort in any condition which can damage the rope safety and service life.**
- **Process the eye survey inspection for overall length of rope each three month.**
- **Replacing the rope in time if found following:**
 - **breaking down.**
 - **the rope diameter reduce by erosion and wear out.(If it is not breaking off)**
 - **Proceed distort, crush, fold, knot or other damage.**
 - **Twist distortion.**
 - **If the rope has dryness and oxidation symptom suggest using the RC oil lubricate slightly. If it disuse long time should protect with lubricating grease.**
- **take down the old rope**
 - **Put down the pulley block and set it at fixing support**
 - **Loose the rope from fixing end.**
 - **Set out the rope from the drum**
 - **Take out the rope double clamping head and unscrew the rope single clamping head but don't take down the single clamping head.**

APPENDIX**COMMON WIRE ROPE DEFECTS**

Wire rope defects requiring immediate replacement and their causes are depicted in the following figures:



Individual wires bend up and protrude through the strands: serious defect caused by stress changing.



Increased diameter of a parallel winding wire rope results in distortion to the metal core due to sudden stress thus caused. Corrosion and signs of wear are often noted on the external layer of the wire rope.



Example of serious bending of the wire rope



Basket-slacking (nest) of a multi-strand wire rope (twisting resistant type) caused by forced rotation of the wire rope reeving through too narrow races or an excessive deviation angle.

Chapter XI Slewing ring

Periodical inspection for fastening bolt of slewing ring (type 011.40.1120)

Frequency of inspection: After the initial 100 hours' running of the slewing ring, the pre-tension of the bolt should be inspected. Then it should be inspected once every 500 hours running. Enough pre-tension should be maintained. At the same time, the pre-tension of the bolt should be inspected each time when the tower crane is to be mounted and dismounted.

Method of inspection: Should the machine be in service, make sure that the bolts to be checked are not exposed to a tensile strength due to load or counter weights.

Using a torque wrench and, if required, a torque multiplier, check that the tightening torque of the bolts corresponds to the values as listed in the table 11-1-1.

Occasional replacement: It may happen that, during an inspection, one or several bolts show a tightening torque beyond the minimum and maximum torques as stated in the table. In such a case, it will be necessary to replace part of or all the bolts.

Systematic replacement: The screws and bolts used for the slewing ring assembly must be systematically replaced every seven years or 14000 hours' operation.

Re-tightening the bolts: No matter it is after the replacement of the bolts, or the slewing ring is re-assembled by using new bolts, the tightening of the bolts should be carried out continuously and symmetrically in the direction of 180°. Then re-tighten them one more time to make sure all the bolts on the circle have the same pre-tension.

Table 11-1-1

| φ (mm) Diameter | Bolt class 10.9 | | Bolt class 12.9 | |
|-----------------|-------------------------|-------|-------------------------|-------|
| | Tightening torque (N.m) | | Tightening torque (N.m) | |
| | Maximal | Rated | Maximal | Rated |
| Φ20 | 580 | 520 | 690 | 620 |
| Φ22 | 780 | 700 | 930 | 840 |
| Φ24 | 1000 | 900 | ◆1080 | ◆1200 |
| Φ27 | 1500 | 1350 | 1800 | 1620 |
| Φ30 | 2000 | 1800 | 2400 | 2160 |

The bolts remarked with◆ are selected for connecting the slewing mechanism of the tower crane, they must be checked weekly. If the bolts become less tightened, please re-tighten with the torque value shown in table 11-1-1.

Maintenance for slewing ring

G: Lubricate



GC: Lubricating oil





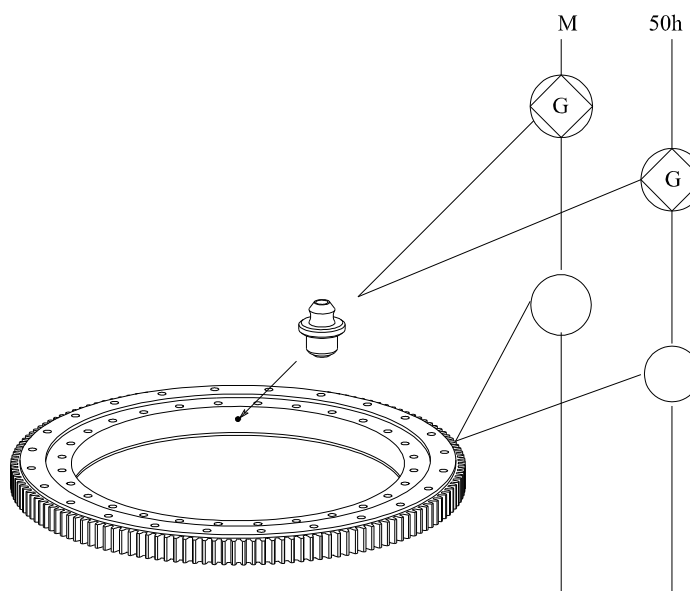







G2: Lubricate (NLGI2)



Chapter XII Tower crane maintenance

Every kind of lubricating symbols (see table 12-1-1)

Table 12-1-1

| Symbols | Type | Code number | International standard or main characteristic |
|---|------|-------------|---|
|  | GO | K-12032-08 | Li (Ca) extreme pressure grease NLGIO grade |
|  | P | P-01032-60 | MOS2 lubricating grease (special purpose) |
|  | RC | Q-12032-13 | MIL--L2105D lubricating oil, SAE80W90 grade |
|  | F | B-01032-48 | high viscosity index special hydraulic oil 40°C-22mm ² /S, 100°C-5.6 mm ² /S |
|  | T | X-01032-45 | ISO6743/4, hydraulic oil HV type, 40°C-68mm ² /S |
|  | E | E-01032-26 | ISO6743/4, hydraulic oil HV type, 40°C-46mm ² /S |
|  | G2 | E-01032-51 | Li (Ca) extreme pressure grease NLGI2 grade |
|  | S000 | H-12032-52 | carbowax / lithium base grease, NLGI000 grade (special purpose) |
|  | G3 | S-12032-38 | lithium base grease, NLGI3 grade |
|  | ATD | | 46MR401 lubricating grease for installing (special purpose) |
|  | GC | | Synthesis basis soap lubricating grease, NLGI2 grade, (special purpose) |

General instruction (see table 12-2-1)

Table 12-2-1

| | |
|---|--------------|
| M | When startig |
| N | Oil level |
| V | Draining |
| R | fillup |
| G | Lubricating |

1. Running-in period

Carry out the first draining of the reduction gears after 450 working hours.

2. Using the grease gun

- 1) Grease all the articulations without grease nipples (such as door and flap hinges, rods, locks and articulations of the safety devices).
- 2) Using any impurity into the oil when checking the oil level or draining, take care to clean the parts located near the plugs.
- 3) The oil quantities shown in this manual are only for the user's reference; it is essential that the oil reaches the lower part of the oil level plug.

3. Checks to be carried out before assembling and disassembling

- 1). Check and adjust the brakes periodically according to the recommended cycles in the manual. Each time before crane erection and dismantling all the mechanisms should be inspected properly.
- 2). For fast erection and self erection tower crane, it required the folded winch to installing and dismantling. So it is necessary to check up each mechanism.
- 3). Make sure that nothing may hinder the good working order (perfect motor and brake supply circuit , fuses in place and in good working order , free sliding of the rod for manual brake release , remove the nut , if required)

Note: It is obvious that in order to perform these checks on an erected crane, the drum must be locked. We insist on these operations which are obligatory and compulsory, ANY CARELESSNESS AT THIS WARNING MAY RESULT IN SERIOUS CONSEQUENCES.

Maintenance schedule:

C: checking G: lubricating N: oil level R: fillup E: replacing
 H: refueling P: air blasting V: draining ☉ checking ● lifetime lubricating

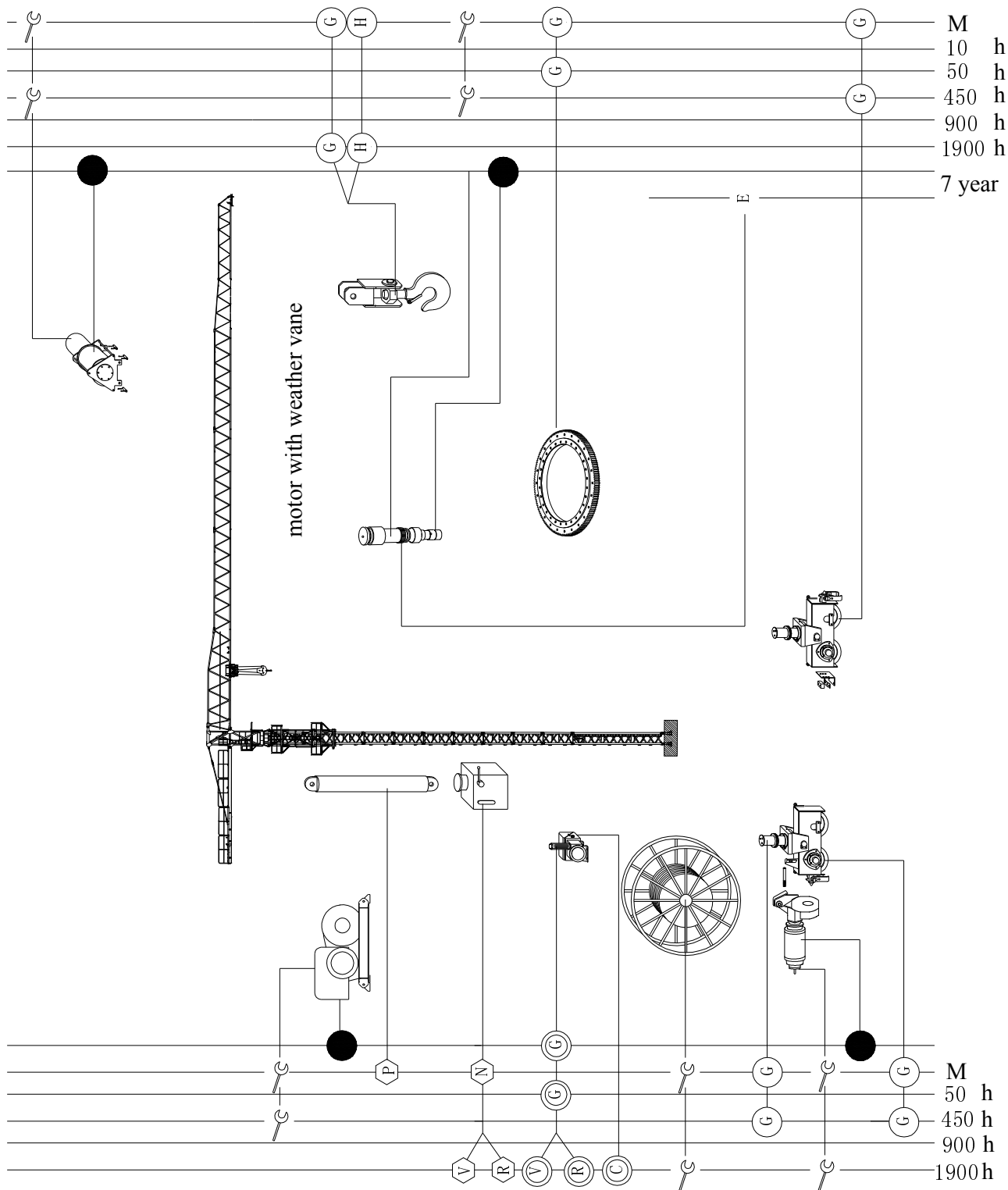

1. Maintenance on trolley mechanism

The following rules should be strictly observed to do any kind of maintenance on trolley:

The operator must tie the safety rope (1) .

When making maintenance on the brake, the operator must ride on the motor and step on the mechanism pedal (2) .

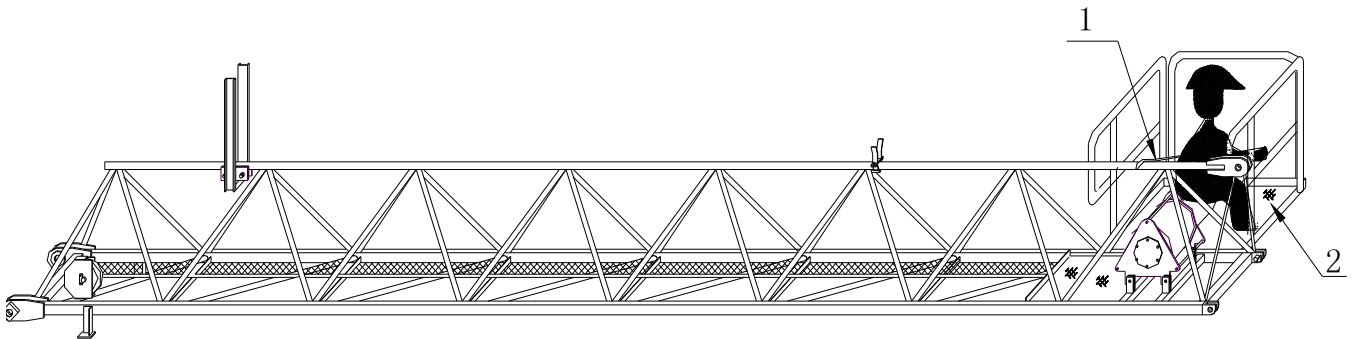

2. Maintenance on hook: The bearing on the traverse beam of the hook must be greased **every 200 hours** using calcium based grease.

- G2 Li (Ca) extreme pressure grease NLGI2 grade

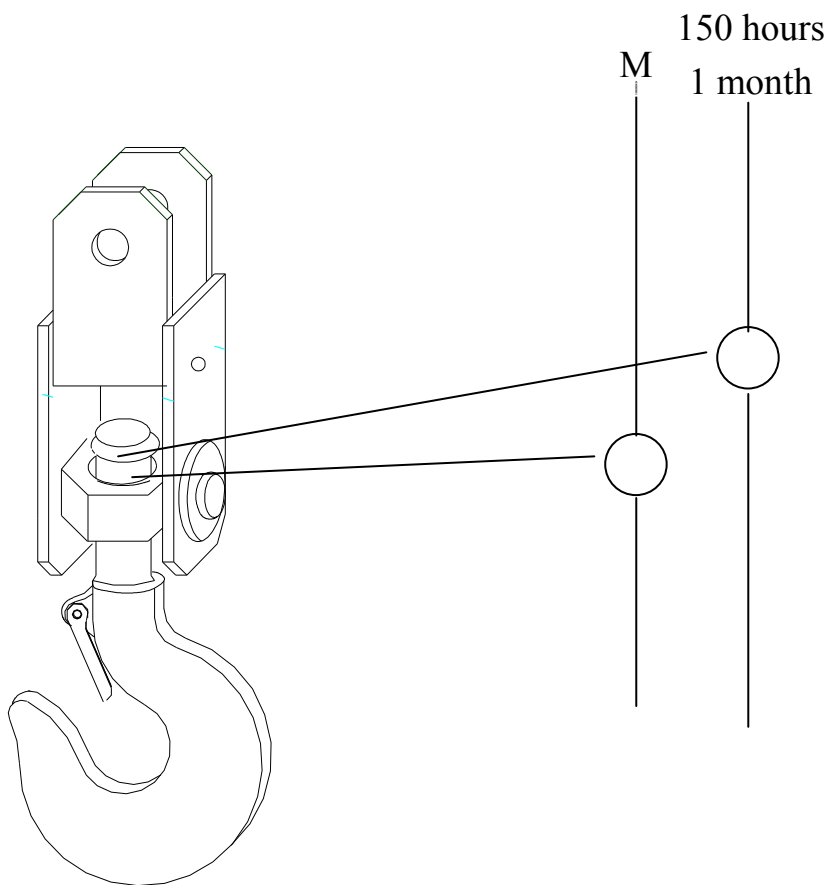

3. Maintenance on rope twist-protector

G: Lubricating ○ Ta / Ca extreme pressure grease NLG12 grade

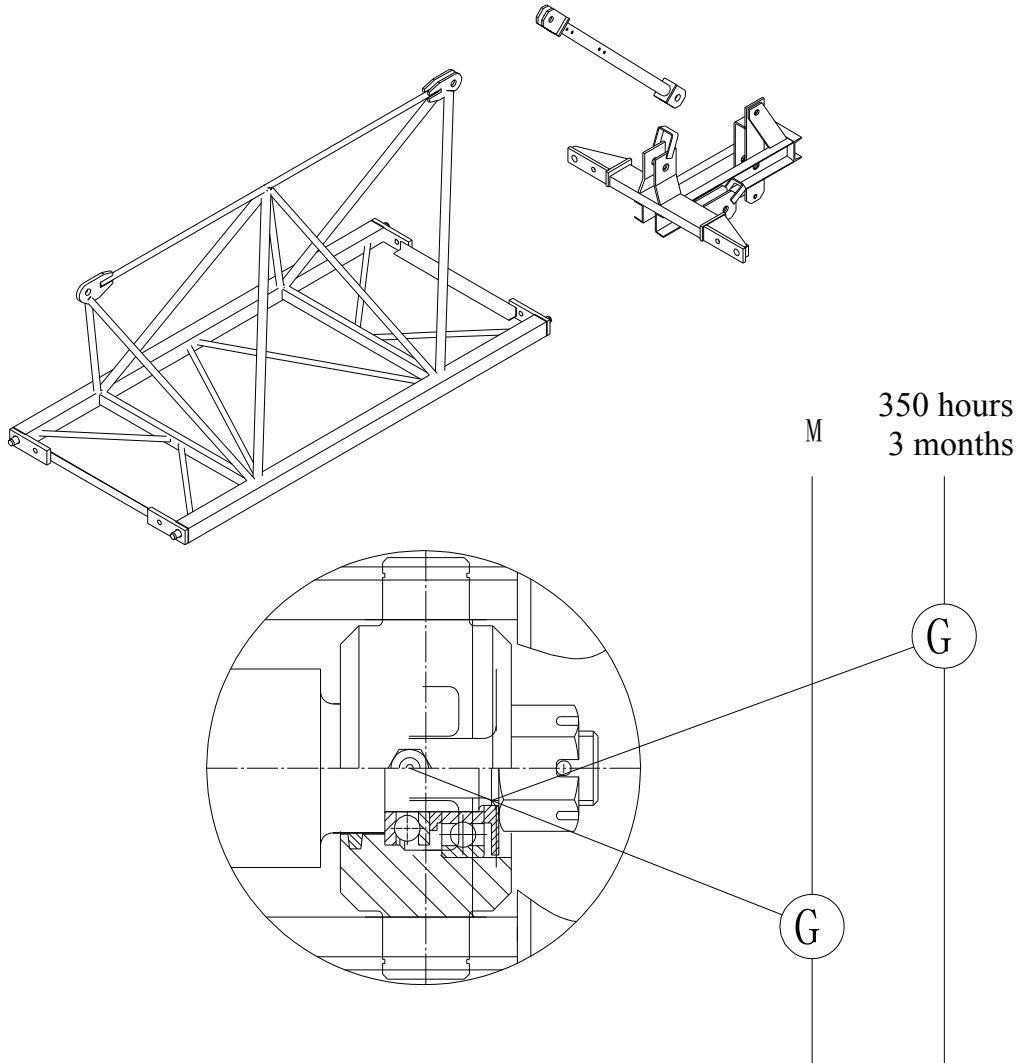

4. Greasing the wire ropes

The wire ropes must be greased every 6 months or, in general, each time when they seem to be dry or tend to oxidize. We recommend to lubricate them very moderately using RCF grease and RC grease. In case of a longer standstill, it is possible to protect the rope by spraying P grease. (Detailed please see chapter X fixing and testing rules for rope)

5. Maintenance for hydraulic pump station

M: when starting N: oil level V: draining R: fillup G: lubricating

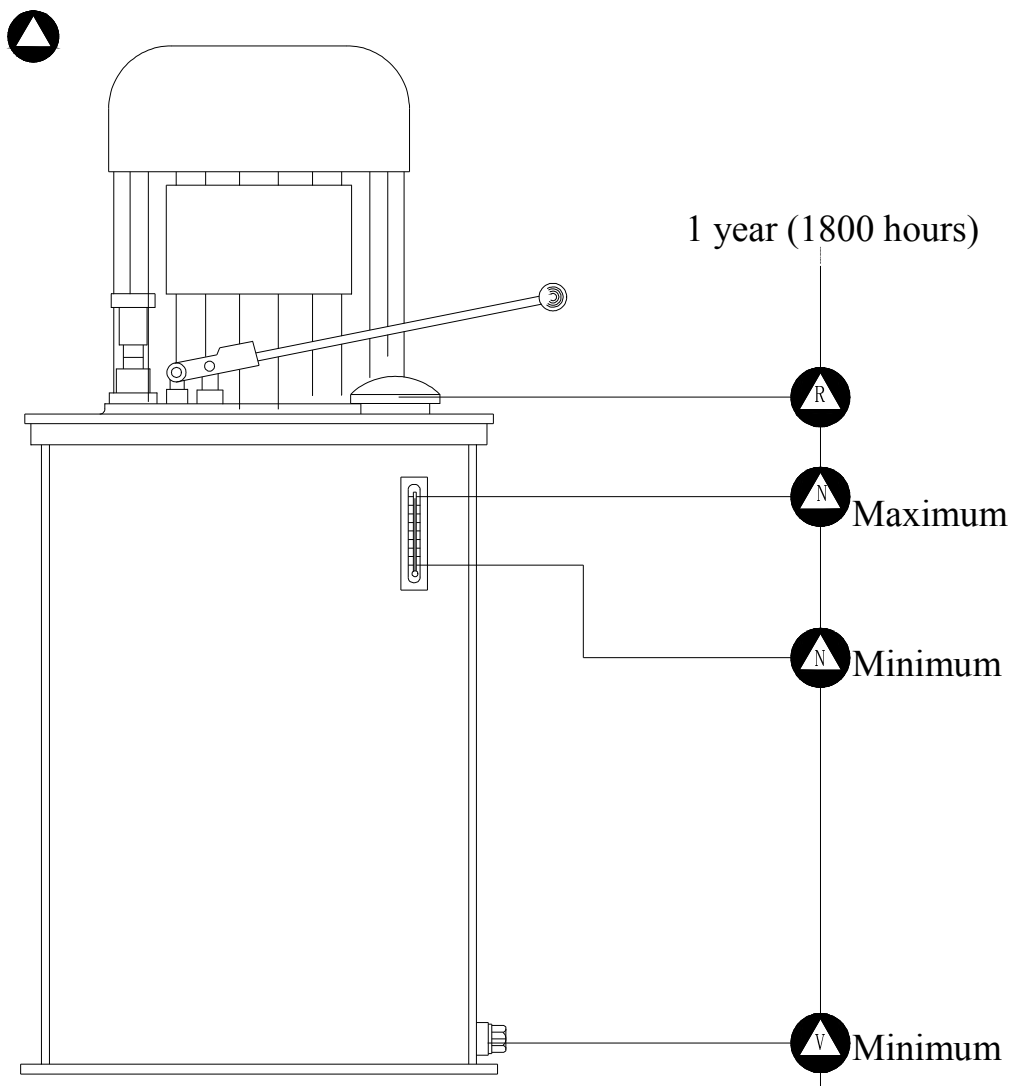

12B-7

Because of different working environment temperature, hydraulic lubricant of using by Hydraulic unit should be different. The user should be added proper hydraulic oil according to the environment temperature.

Number of hydraulic oil

| environmental temperature | -30~-20°C | -20~-10°C | -10 -0°C | 0~20°C | 20~38°C | 38~80°C |
|---------------------------|---|---|-------------------------------------|-------------------------------------|-------------------------------------|---|
| Code | YC-N46D | YC-N32 | YB-N32 | YB-N46 | YB-N68 | YB-N80 above |
| New grade | N46D Low freezing point hydraulic oil | N32# Low freezing point hydraulic oil | N32 Antiwear hydraulic oil | N46 Antiwear hydraulic oil | N68 Antiwear hydraulic oil | Above N80# Antiwear hydraulic oil |
| Original grade | 30D# | 20# | 20# | 30# | 40# | ≥50# |

6. Rope guiding pulley

Before using the rope guiding pulley, grease at the oil fittings and supplement grease every 50 hours (2# AERO Grease ZL45-2). Before greasing, please clean out the waste oil on the shaft.

7. Greasing the slewing ring

Before installing the slewing ring, grease it fully. Then supplement grease every 50 hours. Enough new grease should be applied each time before and after long-term standstill of the tower crane. Each time when greasing, the inside of the rail should be fully greased until oozing from sealing place. Turn the slewing ring slowly while greasing and apply grease evenly.

The tooth face should be cleaned every 10 days and smeared Lubricant grease.

The lubricating grease can be selected according to the following table:

| Bear structure | Working conditions | | Lubricating position | Lubricating grease | | |
|--|---|------|--|---|----------------------------|----------------------------------|
| | | | | Name | Consistency grade | Standard code |
| rubber seal ring for plastic isolation block | low temperature, normal temperature, wet -40°C +60°C | | raceway | extreme pressure lithium base grease | 1#, 2# | BG7324-1994 |
| | | | gear | carbon calcium base grease | ZG-S | SH0369-1992 |
| labyrinth seal for metal isolation block | High temperature and wet | | raceway | extreme pressure lithium base grease | 1#, 2# | GB7323-1994 |
| | | | | MOS2 complex calcium lubricating grease | 2# | |
| | | | gear | 4# high temperature grease | 4# | SY1511-65 |
| | High temperature and wet | | raceway | MOS2 complex calcium lubricating grease | 2# | |
| | | | | gear | 4# high temperature grease | 4# |
| | | | normal temperature, proof seawater corrosion - 50°C | | raceway | 2# complex aluminium base grease |
| | | gear | 4#, complex aluminium base grease | 4# | SH0378-1992 | |

8. Lubricating for hoisting winch

1). Lubricating for hoisting reducer

Fill the lubricating oil before the reducer putting into service, after running 500 hours, drain the oil and fill new oil. After the first time for oiling, replace the oil every 2400 hours. The lubricating oil is N100 gear oil, and fill it to the scale between the oil scales.

2). Lubricating for drum bearing

Fill the lubricating oil in drum bearing before putting into service, after this, fill it every 500 hours, and don't fill too much, it may cause the falling off of seal ring.

Note: Keep the air hole clean and smooth.

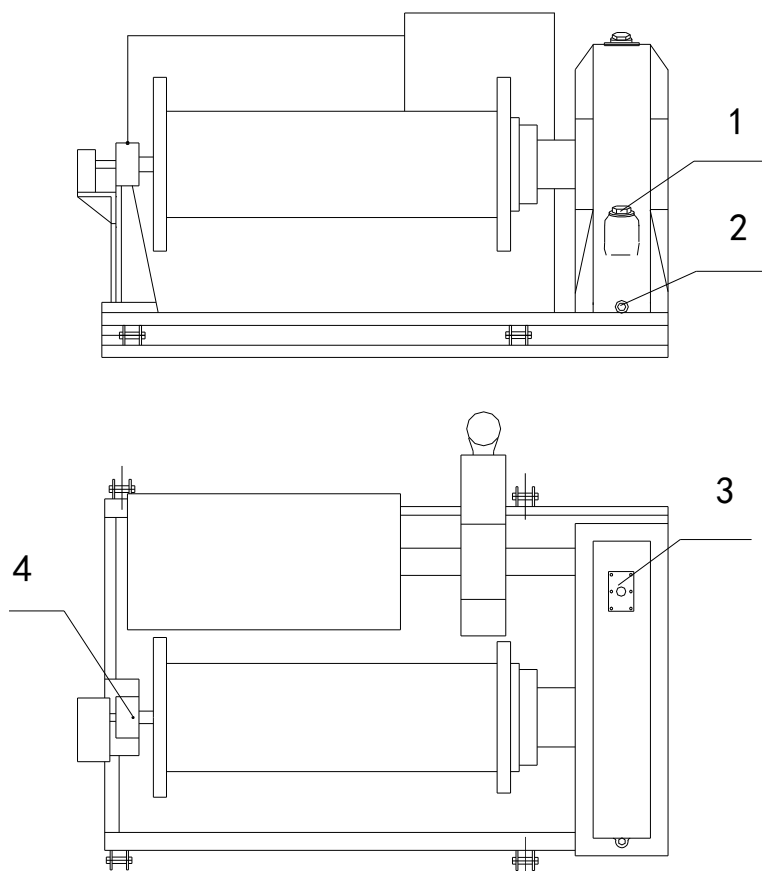

1. oil scale 2. oil draining port 3. filler (inspection port) 4. grease nipple

9. Manintenance for telescoping cage

○ G2

M: when starting;

G: Lubricating

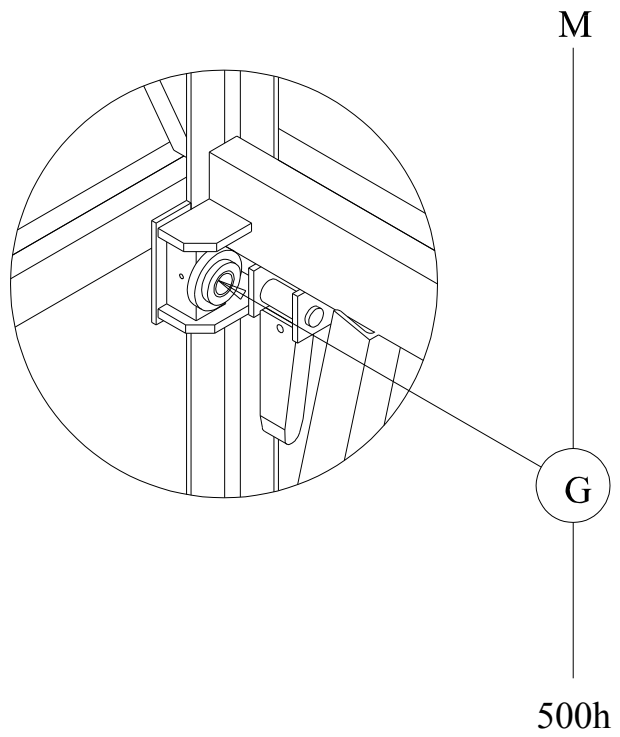
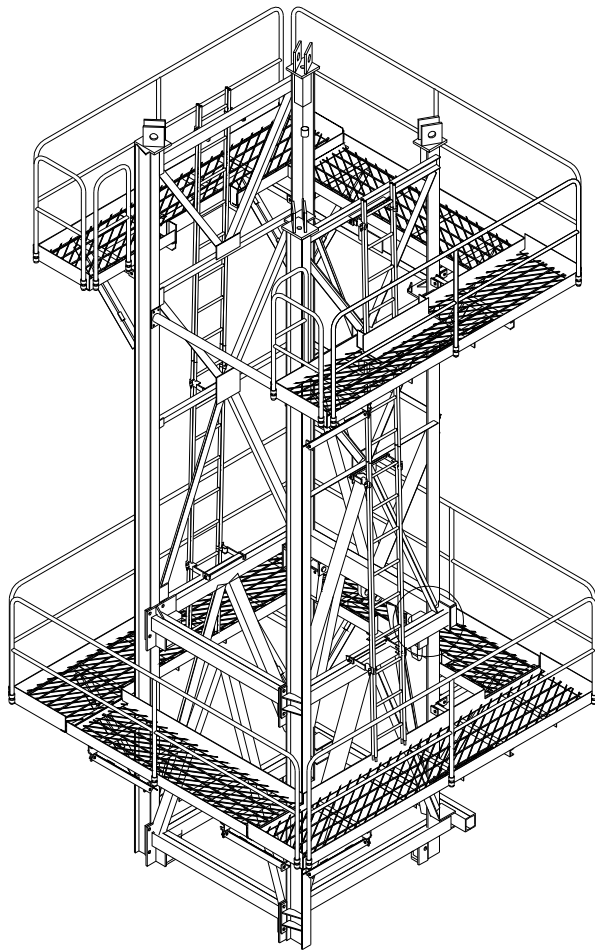

Fushun Yongmao Construction Machinery Co., Ltd.

Add. : No. 3 Yuanda Road, Shuncheng District, Fushun, Liaoning, P.R. China

Tel. : 86-413-7648899, 7649988

Fax. : 86-413-7649999

Postcode : 113126

Website : <http://www.yongmao.com.cn>

E-mail : sun@yongmao.com.cn

Manufacture License of Special Equipment No.: TS2410592 – 2008