

GENERAL PRODUCT MANUAL FOR ABUS CRANES

ABUS overhead travelling crane

ABUS jib crane

ABUS HB crane

ABUS single-rail trolley track

ABUS chain hoist

ABUS wire rope hoist

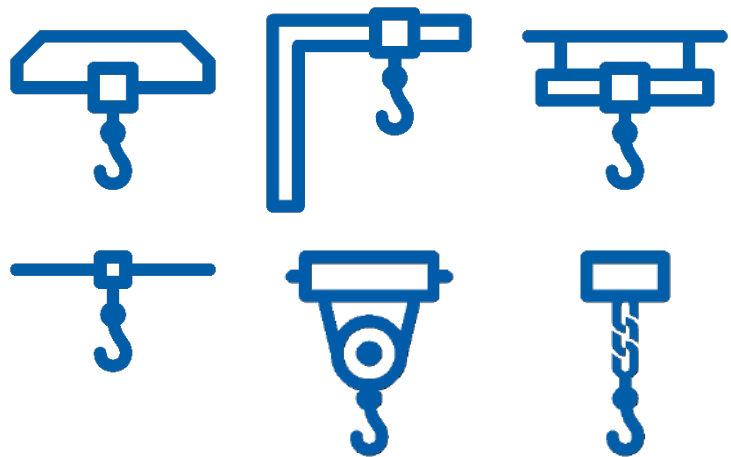

AT A GLANCE:

General instructions regarding safety: page 9

Instructions regarding safety – putting into operation:
page 23

Connecting the crane to the mains supply: page 28

Test before initial commissioning: page 35

Instructions regarding safety – performing
maintenance work: page 55

CRANE: VARIOUS TYPES, VERSIONS AND OPTIONS

This product manual applies to cranes of various types, versions and options. The work steps described and the technical data will vary according to the type, version and options of the crane. The areas of this product manual which do not apply to all cranes, but are applicable only under certain conditions, are enclosed in a dashed box. At the start of the box, the types, versions and options to which the section is applicable are specified.

CRANE (TYPE)



CRANES WITH OVERLAPPING OPERATING RANGE



CRANE ON A CRANE TRACK

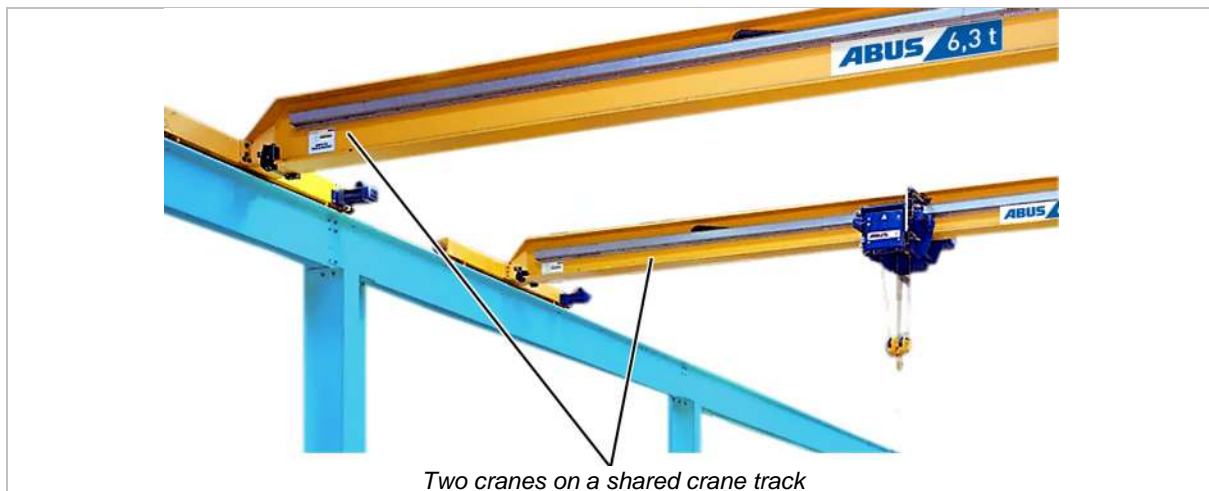

TANDEM OPERATION (OPTIONAL)



TWO TROLLEYS ON ONE CRANE (OPTIONAL)



CRANE AND TROLLEY WITH WALKWAY

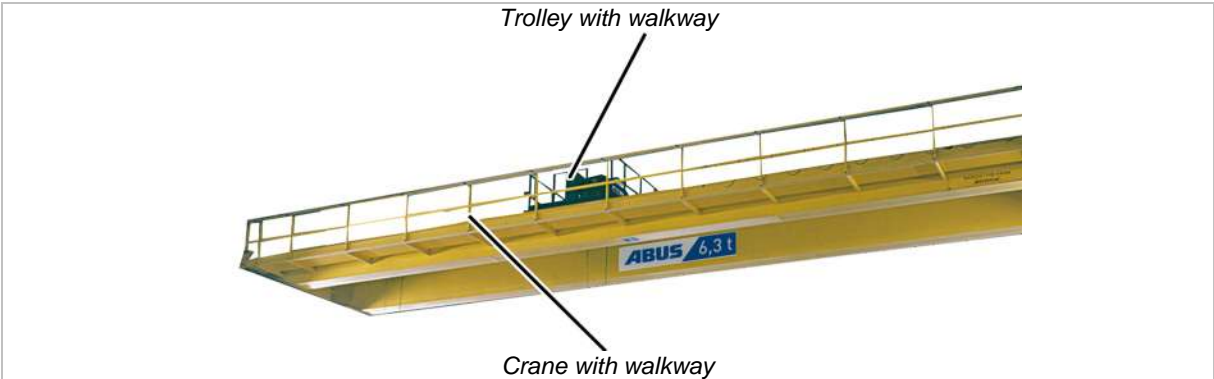

CONTENTS

GENERAL INFORMATION 6

- At the start 6
- Instructions regarding safety: For anyone, who performs work with or on the crane, or works nearby..... 9
- Instructions regarding safety: For the end user of the crane..... 11
- The crane 15
- Storage of the crane 22

INSTALLING AND CONNECTING 23

- Instructions regarding safety: Before putting into operation..... 23
- Instructions regarding safety: When putting into operation..... 25
- Instructions regarding safety: After putting into operation..... 26
- Installation overview 26
- Equipping the crane for operation in unprotected environments 27
- Connecting the crane to the mains supply 28
- Ensuring electromagnetic compatibility (EMC) 35
- Test before initial commissioning 35
- Shutting down the crane..... 37
- Disassembly 37
- Reassembling the crane 37

INSPECTION38

- At the start 38
- Scope of the inspection 39
- Checking the load hook 41
- Inspecting the conductor system 44
- Inspecting the wire rope 45
- Inspecting the chain..... 46
- Basics for determining the remaining service life..... 47
- Checking the remaining service life . 48
- Checking the test log book 49
- Documenting the test 49
- Acceptance test after substantial changes..... 49
- Testing of components subject to especially high stress 50
- General plan 51

MAINTENANCE53

- Switching off the crane..... 53
- Instructions regarding safety: Prior to maintenance 55
- Instructions regarding safety: During maintenance 56
- Instructions regarding safety: After maintenance 57
- Releasing the crane 57
- Switching to emergency control by pendant control 57
- Modifying the crane 58
- ABUS Service..... 58
- Lubricants..... 59
- Wiring diagrams 59
- Declaration of Conformity, Declaration of Incorporation..... 60

GENERAL INFORMATION

APPLIES TO ANYONE WHO USES THE CRANE OR WORKS NEARBY

AT THE START

USING THIS PRODUCT MANUAL

The following symbols are used in this product manual:



DANGER TO PERSONS!

This warning notice indicates hazards for persons.



DANGER FROM ELECTRIC SHOCK!

This warning notice indicates hazards for persons due to incorrect handling of the electrical system and electricity.



DANGER FROM FALLING SUSPENDED LOAD!

This warning notice describes hazardous situations that can lead to the suspended load falling.



NOTICE OF POSSIBLE DAMAGE!

This notice describes situations in which a component could be damaged.



This is an instruction regarding an action and prompts you to perform a work step.

- This is the result of an action and describes what happens on the device.
- This is a list.

ONLY WITH...

A section that appears in a box framed by a dashed line is only applicable for certain types, versions or options. The condition to which the section applies is specified at the beginning in the heading "Only with...".

INSTRUCTIONS FOR THE PRODUCT MANUAL

Read the product manual through carefully before beginning work. Also be sure to observe additional product manuals for accessories and components.

Afterwards, keep the product manual available in the vicinity of the crane. It must be accessible to all who work with or on the crane.

In the case of reselling or hiring out, always provide the product manual together with the crane.



OBSERVE THE SAFETY INSTRUCTIONS AND WARNINGS!

The safety instructions (general) and the warnings (before the respective operative instruction) in this product manual warn against dangers that cannot be eliminated through design.

Failure to heed these safety instructions or warnings can result in people being killed or injured.

Carefully read and follow the safety instructions and warnings and the entire product manual!



OBSERVE THE TECHNICAL DOCUMENTATION OF THIRD-PARTY MANUFACTURERS!

The technical documentation for additional components (e.g. radio remote control, lifting tackle,...) contains important information on operation as well as additional safety instructions.

Carefully read and observe all documentation!

NOTE REGARDING THE DESIGNATION "CRANE"

The term "crane" as used in all product manuals refers to every ABUS product with which a load can be lifted and/or transported.

The term "crane" also refers to all overhead travelling cranes, jib cranes, HB cranes and other cranes including trolley (with wire rope hoist or chain hoist). Solo wire rope hoists and solo chain hoists are also referred to as "crane".

PRINTING OUT PRODUCT MANUALS OR MAKING THEM AVAILABLE PER COMPUTER

The product manuals belonging to this crane are available on the enclosed data carrier as files in PDF format. Some of these product manuals may also be enclosed in printed format in the documentation folder of the crane.

All supplied product manuals (on data carrier or printed) must be made continually available to all persons working with or on the crane.

- ➔ Print out all product manuals supplied on the data carrier and store them near the crane. Keep the product manuals in a place accessible to all persons who work with or on the crane.
- ➔ Alternatively, make all product manuals supplied on the data carrier available per computer. In doing so, make sure the computer is able to display the PDF files and is always operational, and that all persons who work with or on the crane can access this computer.
- ➔ Keep the product manual "Operating the ABUS crane" available in the vicinity of the crane. This product manual contains important information for the crane operator and should be within easy reach at all times.

PROPER USE

The crane is designed for the lifting and lowering of correctly attached loads and, depending on design, moving them as well.



OBSERVE THE PRODUCT MANUALS!

In addition to the points described here, all information in the section "Proper use" in the other supplied product manuals also applies.

ABUS cranes are designed for these applications:

- Overhead travelling crane for all-round moving of loads.
- Jib crane for moving loads in a circular direction.
- HB crane for all-round moving of lightweight loads.
- Single-rail trolley track for moving loads in a linear direction.
- Mobile gantry crane for location-independent all-round moving of lightweight loads.
- Solo chain hoist and solo wire rope hoist for the stationary lifting and lowering of loads.
- During operation, observe the classification according to FEM, duty cycle and switching rate. See the product manual "Operating the ABUS crane".
- Only operate the hoist if the actual hours of use are fewer than the number of hours representing the theoretical service life.
- Only use the crane in chemically non-aggressive environments that pose no risk of explosion.
- Long-term usage of the crane only in weatherproof areas. Temporary use in unprotected environments (outdoors in rain, snow or cold weather) is permitted. For longer operation in unprotected environments, modifications must be made to the crane. See "Equipping the crane for operation in unprotected environments", page 27.

In windy environments, even short-term use is prohibited. If the crane is to be used in windy conditions, modifications must be made to the crane. See "Equipping the crane for operation in unprotected environments", page 27.

REGULATIONS

The installation has been built and tested according to European standards, rules and regulations applicable at the time of its manufacture. The conventions applied during design and construction are specified in the Declaration of Conformity or the Declaration of Incorporation. The conventions must also be observed for installation, operation, inspection and maintenance, as must the applicable occupational health and safety regulations.



DANGER TO PERSONS!

Non-observance of the regulations can result in the death of persons or serious accidents.

To ensure that the work can be performed safely, thorough instruction in regard to this product manual and the regulations is necessary.

Which provision applies in individual cases will greatly depend on the crane's use and the national regulations. Review and observe all applicable and current regulations, including the occupational health and safety regulations. Refer also to the Declaration of Conformity or Declaration of Incorporation.

This product manual is based on the regulations and directives applicable in Germany and the European Union.

If the crane is operated in a different country, the instructions given in this product manual still apply. They then supplement the national regulations. The content specified in the product manuals should then be considered the minimum requirements which must be met in any case. The national regulations supplement these requirements, but do not reduce them.

Exception: If the national regulations represent an explicit contradiction to the contents of the product manual, the national regulations have priority.

WARRANTY

- ABUS assumes no liability for damages that were caused by improper use, inadequately trained personnel, incorrect performance of work, nor for any changes, reconstruction or other modification of the crane or crane components which were not approved by ABUS.
- Any warranty claim becomes invalid if components were modified without consent, the crane or crane components were installed, used or serviced in any way other than that described in this product manual, or if parts other than original ABUS replacement parts were used.
- Safe operation of the crane or crane components is only guaranteed if original ABUS replacement parts are used.

PREPARING A RISK ASSESSMENT

In connection with the crane, dangerous situations can arise in all operating modes (during operation, at a standstill, during maintenance work) and in all product phases.

Why, when and where these hazards occur as well as who causes them and how, depends on a great number of different conditions. Among these are the application area of the crane, the conditions and work routine within the building, the interaction with other machines, etc.

The hazards described in this and all other product manuals refer to the standard applications of the crane and especially cover the dangers arising directly from the crane itself.

In order to take all other arising hazards into account, the end user must create a risk assessment and factor in all possible risks in all modes of operation.

Special transport tasks, such as transport using two trolleys, tandem operation, turning of loads or similar, pose additional risks and must be additionally taken into account.

The end user must then undertake the appropriate measures and precautions to minimise or eliminate these risks.

The end user is responsible for the risk assessment and the implementation of appropriate countermeasures.

INSTRUCTIONS REGARDING SAFETY: FOR ANYONE, WHO PERFORMS WORK WITH OR ON THE CRANE, OR WORKS NEARBY

Observe these instructions for safe handling of the crane. Special hazard notices are located in the corresponding sections in which the danger arises.



OBSERVE THE PRODUCT MANUALS!

In addition to the points described here, all information in the section "Instructions regarding safety" in the other supplied product manuals also applies.

These instructions specify basic dangers that can arise from the crane. Additional dangers must be determined through a risk assessment and then eliminated.



DANGER TO PERSONS WHEN STEPPING ONTO THE CRANE TRACK!



There are various hazards on the crane and crane track, e.g. due to the height, electricity, temperature, risk of slippage (from oil and dirt), unintended travelling, etc.

As a result of this people can be killed or injured.

Unauthorised persons are not permitted to step onto the crane track or into the crane. This also applies to cranes and wire rope hoists with walkways. Only trained and authorised persons may enter the crane or crane track.



DANGER TO PERSONS DUE TO LACK OF PROTECTIVE CLOTHING!



In all work there is a risk of head injury (e.g. collision with load hook), hands being crushed (e.g. on the load hook or when slinging the load) and injuries to the feet (e.g. due to falling lifting tackle).

As a result of this people can be injured.

Wear suitable protective clothing (e.g. industrial safety helmets, safety shoes with reinforced toes, protective gloves) for all work on or using the crane. The actual combination of personal safety gear will depend on the conditions in the building and the use of the crane, and is determined by the risk assessment.

⚠ DANGER TO PERSONS DUE TO LOOSE CLOTHING!



For all items which are worn loosely, (e.g. jewellery, open jackets, ties, scarves, long hair), there is a danger of these inadvertently catching on the crane (e.g. on the load hook when lifting a load or in a motor during repair work).

As a result of this people can be injured.

Before beginning all work, tie long hair back, do not wear any open clothing and remove any jewellery.

⚠ DANGER TO PERSONS DUE TO INGESTION OF INTOXICANTS!



Alcohol, drugs and certain medications can impair a person's reaction time and ability to concentrate.

This could result in hazards not being recognised quickly enough.

Persons working with or on the crane may not be under the influence of drugs, alcohol, or medications which inhibit their reaction time or motor coordination.

INSTRUCTIONS REGARDING SAFETY: FOR THE END USER OF THE CRANE

Follow these instructions to ensure employees use the crane safely.



OBSERVE THE PRODUCT MANUALS!

In addition to the points described here, all information in the section "Instructions regarding safety" in the other supplied product manuals also applies.



DANGER OF LOAD DROP DUE TO CORROSIVE ENVIRONMENT!



Fumes from corrosive materials (e.g. acids and lyes) attack metallic and plastic parts on the crane and corrode them.

This could damage the crane and cause the load to fall.

The crane may not be used in chemically aggressive environments. Only use cranes in corrosive environments if they have been specially designed for those conditions.



DANGER TO PERSONS DUE TO GASES!



Electrical sparks can occur within the panel on the crane or in the pendant control, causing the gases to explode.

As a result of this people can be killed or injured.

The entire crane is prohibited from use in areas at risk of explosion. This includes the pendant control or transmitter. If used in areas at risk of explosion, the panel and motors, among other components, must be of an explosion-proof design. This is not the case for the standard version.



DANGER TO PERSONS FROM LOAD DROP!



Continuous operation outdoors could cause damage to the crane which could result in a load drop or electric shock.

As a result of this people can be killed or injured.

Do not operate the crane outdoors on a permanent basis. The crane is designed for continuous use in weatherproof environments. Temporary use outdoors in rain or snow is permitted. For longer operation outdoors, modifications must be made to the crane. See “Equipping the crane for operation in unprotected environments”, page 27.

In windy environments, even short-term use is prohibited. If the crane is to be used in windy conditions, modifications must be made to the crane. See “Equipping the crane for operation in unprotected environments”, page 27.



DANGER TO PERSONS DUE TO MISCOMMUNICATION!



If persons working simultaneously with the crane (e.g. crane operators and load handlers) cannot make themselves perfectly understood, dangerous situations with the load can occur, such as lifting the load prematurely.

As a result of this people can be injured!

Especially in loud workplaces, the communication must be agreed upon in advance. Ways of ensuring one is understood include clear hand signals, signal tones or wireless equipment.



DANGER TO PERSONS IF THEY ARE NOT TRAINED!



Special technical expertise is required to correctly sling and safely lift and move loads.

Otherwise, accidents could occur.

Personnel working with the crane (e.g. crane operators and load handlers) must first have received instruction. The required knowledge must be imparted through regular trainings providing the operator with instruction. The end user is responsible for this instruction. The instruction is to be given based on the following documentation:

- All supplied ABUS product manuals
- National training requirements
- Operating instructions created by the end user
- General occupational health and safety requirements
- Regulations based on the risk assessment

It is recommended to document this instruction in writing.



DANGER TO PERSONS FROM LOAD DROP!

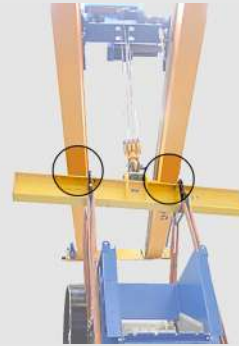

For certain lifting tackles and crane types, dangerous situations can occur if the load hook is run to the very top. For example, a crosshead under the main girder can impact against a double-girder travelling crane. Or a round sling can be torn from the main girder of a crane with a side-mounted trolley.

This could cause the load to fall, killing or injuring people.

When carrying out a risk assessment, check how high the load hook should be allowed to travel with the respective lifting tackle for which it is designed. Dangerous situations must be determined through a risk assessment and then avoided, for example, by moving the hoist limit switch.

**ONLY WITH CRANES WITH
OVERLAPPING OPERATING
RANGES**



**DANGER OF LOADS DROPPING
DUE TO CRANES COLLIDING
WITH EACH OTHER!**



If several cranes are used in succession on a single crane track or above one another on multiple levels, their respective operating ranges may overlap.

This can give rise to dangerous situations (e.g. the load from the top crane can collide with the bottom crane).

Dangerous situations involving overlapping operating ranges must be determined in advance through a risk assessment and then avoided, for example, by employing an anti-collision device.

ONLY WITH TANDEM OPERATION



**DANGER OF LOADS DROPPING
DURING TANDEM OPERATION!**



If a load is transported by two separately controlled cranes, there is the danger that the two crane operators will control the cranes differently.

If a load is transported by two cranes with a tandem control system, there is a risk that a breakdown of one crane will not be detected immediately.

This could cause the load to fall, killing or injuring people.

If a load is transported by several cranes, dangerous situations must be determined through a risk assessment and avoided through appropriate measures. The cranes and the load must be monitored continuously during tandem operation.

THE CRANE

This section provides a rough overview of the ABUS product range. Other combinations of cranes and trolleys are possible. Additional types of cranes and trolleys are also available.

DESCRIPTION OF THE SINGLE-GIRDER TRAVELLING CRANE

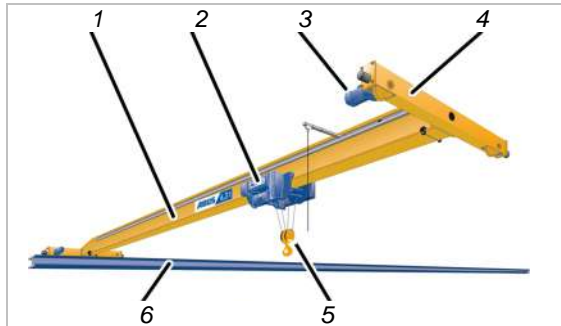

- 1: Main girder (ELV version)
- 2: Trolley (wire rope hoist or chain hoist)
- 3: Crane travel drive
- 4: End carriage
- 5: Bottom block and load hook
- 6: Crane track

DESCRIPTION OF THE DOUBLE-GIRDER TRAVELLING CRANE

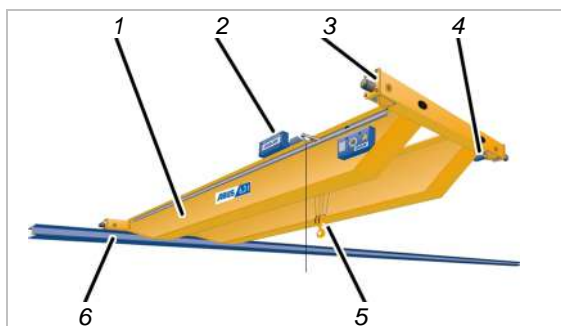

- 1: Main girder
- 2: Trolley (wire rope hoist)
- 3: End carriage
- 4: Crane travel drive
- 5: Bottom block and load hook
- 6: Crane track

DESCRIPTION OF THE UNDERSLUNG TRAVELLING CRANE

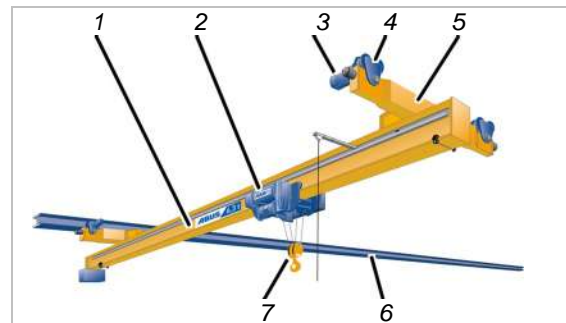

- 1: Main girder
- 2: Trolley (wire rope hoist or chain hoist)
- 3: Crane travel drive
- 4: Crane trolley
- 5: End carriage
- 6: Crane track
- 7: Bottom block and load hook

DESCRIPTION OF THE DEVICE WALL TRAVELLING CRANE

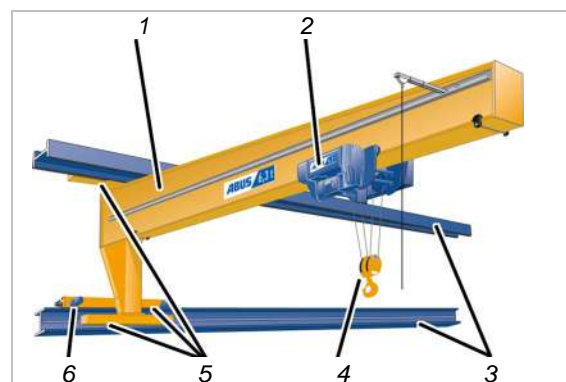

- 1: Main girder
- 2: Trolley (wire rope hoist or chain hoist)
- 3: Crane track
- 4: Bottom block and load hook
- 5: End carriage
- 6: Crane travel drive

DESCRIPTION OF THE SEMI-GOLIATH CRANE

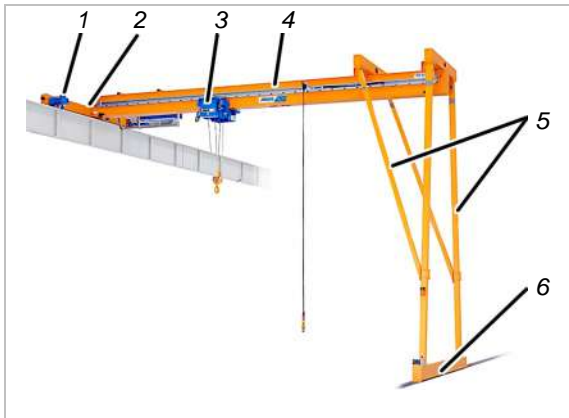

- 1: Crane travel drive
- 2: Upper end carriage
- 3: Trolley (wire rope hoist)
- 4: Main girder
- 5: Portal support
- 6: Lower end carriage

DESCRIPTION OF THE PILLAR SLEWING JIB CRANE

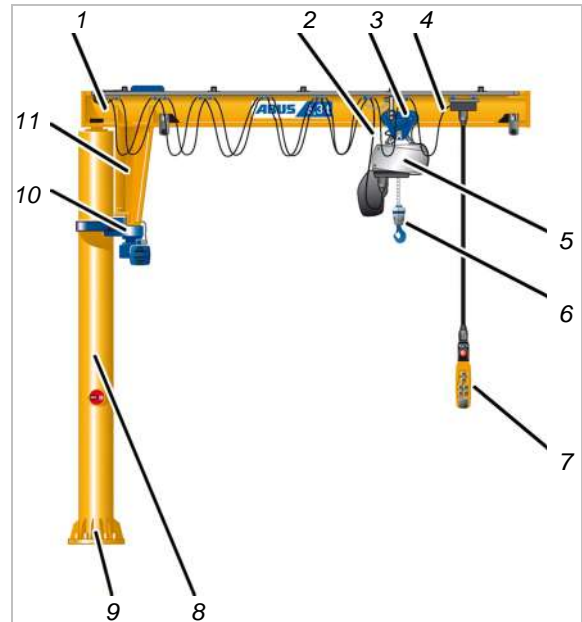

- 1: Jib arm
- 2: Trolley power supply
- 3: Hoist trolley
- 4: Mobile control (optional)
- 5: Trolley (wire rope hoist or chain hoist)
- 6: Load hook
- 7: Pendant control
- 8: Pillar
- 9: Pillar base
- 10: Slewing gear unit
- 11: Jib bracket

DESCRIPTION OF THE WALL JIB CRANE

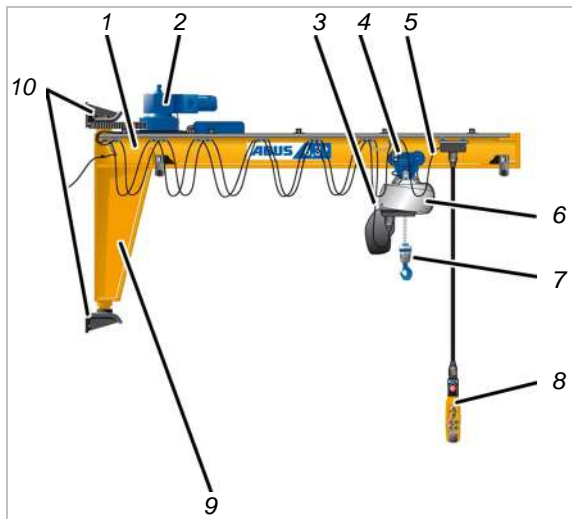

- 1: Jib arm
- 2: Slewing gear unit
- 3: Trolley power supply
- 4: Hoist trolley
- 5: Mobile control (optional)
- 6: Trolley (wire rope hoist or chain hoist)
- 7: Load hook
- 8: Pendant control
- 9: Jib bracket
- 10: Wall mounts

DESCRIPTION OF THE HB CRANE MONORAIL SYSTEM

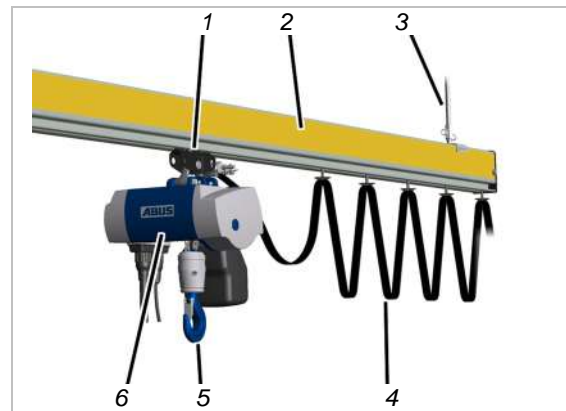

- 1: Suspension
- 2: Trolley track
- 3: Hoist trolley
- 4: Trolley power supply
- 5: Load hook
- 6: Trolley (chain hoist)

DESCRIPTION OF THE HB CRANE TYPE SINGLE-GIRDER CRANE

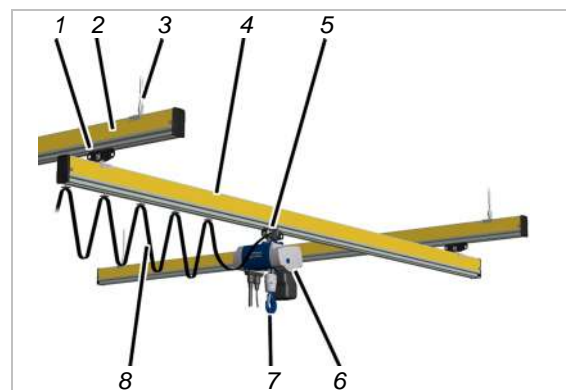

- 1: Crane trolley
- 2: Crane track
- 3: Suspension
- 4: Crane girder
- 5: Hoist trolley
- 6: Trolley (chain hoist)
- 7: Load hook
- 8: Trolley power supply

DESCRIPTION OF THE SINGLE-RAIL TROLLEY TRACK



- 1: Trolley track
- 2: Trolley (wire rope hoist or chain hoist)
- 3: Bottom block and load hook
- 4: Pendant control

DESCRIPTION OF THE MOBILE GANTRY CRANE



- 1: Main girder
- 2: Hoist trolley
- 3: Trolley power supply
- 4: Portal support
- 5: End carriage
- 6: Pendant control
- 7: Load hook
- 8: Trolley (chain hoist)

DESCRIPTION OF THE SOLO CHAIN HOIST



- 1: Housing
- 2: Bottom block and load hook
- 3: Pendant control
- 4: Chain box

DESCRIPTION OF THE DEVICE SINGLE-RAIL TROLLEY

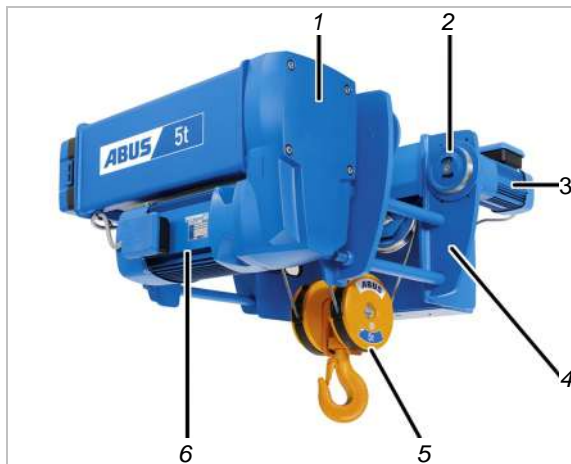

- 1: Hoisting gear
- 2: Hoist trolley
- 3: Trolley drive
- 4: Trolley frame
- 5: Bottom block and load hook
- 6: Hoist motor

DESCRIPTION OF THE DEVICE SIDE-MOUNTED TROLLEY

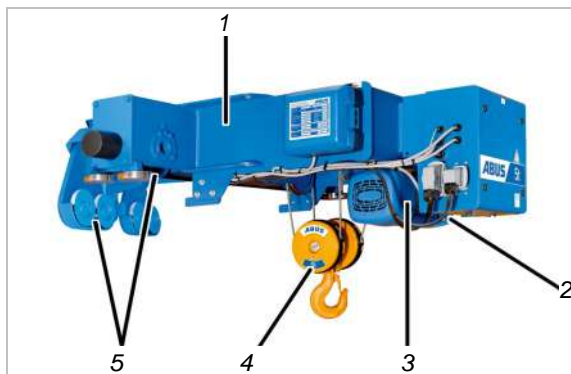

- 1: Trolley frame
- 2: Hoisting gear
- 3: Hoist motor
- 4: Bottom block and load hook
- 5: Hoist trolley

DESCRIPTION OF THE DEVICE DOUBLE-RAIL TROLLEY

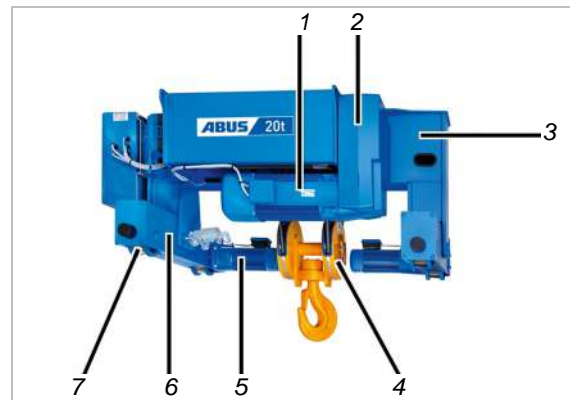

- 1: Hoist motor
- 2: Hoisting gear
- 3: Trolley frame
- 4: Bottom block and load hook
- 5: Trolley drive
- 6: End carriage
- 7: Hoist trolley

DEVICE DESCRIPTION OF LOWER FLANGE TROLLEY

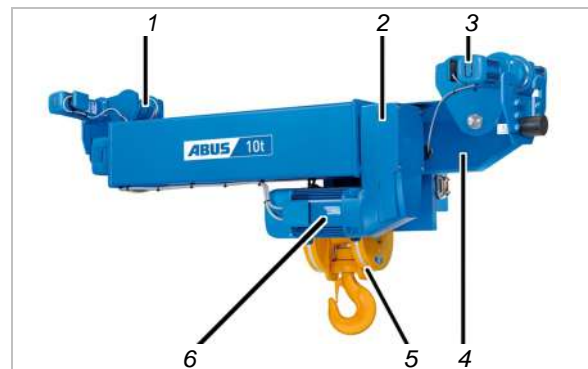

- 1: Hoist trolley
- 2: Hoisting gear
- 3: Trolley drive
- 4: Trolley frame
- 5: Bottom block and load hook
- 6: Hoist motor

PERFORMANCE FEATURES

The single- and double-girder travelling crane and the underslung travelling crane:

- The cranes are designed for all-round moving of loads in a building or within a section of a building.
- The crane travels on a crane track, which is fastened to building supports or concrete supports beneath the hall ceiling or on a separate supporting structure.
- The cranes have a wire rope hoist or a chain hoist with a manually driven or electric trolley (HF/EF).

The wall travelling crane:

- The crane is designed for all-round moving of loads within the operating range on a building wall.
- The crane travels on a crane track, which is fastened laterally to building supports or concrete supports.
- The crane has a wire rope hoist or a chain hoist with a manually driven or electric trolley (push trolley/electric trolley).

The semi-goliath crane:

- The crane is designed for all-round moving of loads within the operating range on a building wall.
- The semi-goliath crane travels on the building wall with the upper end carriage on a crane track. It runs to the middle of the building with the lower end carriage on the floor of the building.
- The crane has a wire rope hoist as a trolley.

The pillar slewing jib crane:

- The crane is designed for the moving of loads in a circular direction or arc within the operating range around the crane pillar.
- The crane pillar is fixedly anchored to the floor of the building or a foundation specially created for it.
- The crane has a wire rope hoist or a chain hoist with a manually driven or electric trolley (push trolley/electric trolley), depending on type.

The wall jib crane:

- The crane is designed for the moving of loads in an arc within the operating range around the wall mounting.
- The crane is fixedly anchored to the building wall, building support, or a concrete support.
- The crane has a wire rope hoist or a chain hoist with a manually driven or electric trolley (push trolley/electric trolley), depending on type.

The HB crane:

- The HB single-girder and double-girder cranes are designed for all-round moving of lightweight loads within the operating range.
- The monorail and double-rail systems are designed for moving lightweight loads in a linear direction.
- The cranes are suspended from HB crane runways, which are fastened under the hall ceiling or on a separate supporting structure.
- The crane has a chain hoist as a trolley.

The single-rail trolley track:

- The crane is designed for moving loads in a linear direction within the operating range.
- The crane track is fastened to the building wall, on building supports, concrete supports, or on a separate supporting structure.
- The crane has a wire rope hoist or a chain hoist with a manually driven or electric trolley (push trolley/electric trolley).

The mobile gantry crane:

- The crane is designed for moving lighter loads exclusively within the direct environment of the operating range.
- The crane can be used flexibly in different operating ranges independently of the location.
- The crane runs on four castors, freely movable on level ground.
- The crane has a chain hoist as a trolley.

The solo chain hoist:

- The solo chain hoist is designed for the stationary lifting and lowering of loads.
- It is stationary and fastened to an appropriately dimensioned supporting structure.

The single-rail trolley:

- The wire rope hoist serves as a trolley on single-girder travelling cranes.
- The wire rope hoist has a hoist trolley with which it travels along the lower flange of the main girder.

The side-mounted trolley:

- The wire rope hoist serves as a side-mounted trolley on single-girder travelling cranes.
- The wire rope hoist has a two-part hoist trolley. One part is used to run the wire rope hoist along the trolley track, which is mounted on the side of the main girder. The load hook hangs from the side of the main girder on which the trolley track is mounted. On the other side of the main girder, the other part of the hoist trolley grips onto the upper flange.

The double-rail trolley:

- The wire rope hoist serves as a trolley on double-girder travelling cranes.
- The wire rope hoist has two end carriages with which it travels along the trolley track of the main girder.

The lower flange trolley:

- The wire rope hoist serves as a trolley on single-girder travelling cranes.
- The wire rope hoist has hoist trolleys with which it travels along the lower flange of the main girder.

TECHNICAL DATA



OBSERVE THE PRODUCT MANUALS!

In addition to the points described here, all information in the section “Technical data” in the other supplied product manuals and in the appropriate crane test log book in the corresponding data sheets also applies.

Normal ambient conditions during operation:

	Range
Ambient temperature	-10 °C to +40 °C
Height position	Up to 1000 m above sea level

Ambient conditions for a complete crane including control.

Operation in other ambient conditions (e.g. at a higher ambient temperature) is in many cases possible. For questions regarding individual on-site conditions in the building (e.g. duration and type of heat and its influence on the crane), ABUS Service will gladly be of assistance. See “ABUS Service”, page 58.

ONLY WITH TRAVEL DRIVES AND HOIST DRIVES

This section only applies to travel drives and hoist drives.

	Range
Ambient temperature	-10 °C to +40 °C
Ambient temperature (for reduced duty cycle)	+40 °C to +65 °C

Ambient conditions exclusively for travel and hoist drives.

Travel and hoist drives can also be used at a reduced duty cycle and switching rate, even at an ambient temperature of +40°C to +65°C.

Operation at higher ambient temperatures:

Duty cycle according to type plate	Modified duty cycle at ambient temperatures of +40 °C to +65 °C
60 %	30 %
50 %	25 %
40 %	20 %

Switching rate according to type plate	Modified switching rate at ambient temperatures of +40 °C to +65 °C
420	210
360	180
300	150
240	120
180	90

- ➔ At ambient temperatures of +40°C to +65°C, reduce the duty cycle and switching rate according to the tables.

Operation at higher elevations:

At higher elevations, the crane will be less well cooled due to the reduced air pressure.

- ➔ Reduce the duty cycle and switching rate at higher elevations.

MECHANICAL DESIGN LIFE

The mechanical design life of the crane is 20 to 25 years.

STORAGE OF THE CRANE



OBSERVE THE PRODUCT MANUALS!

In addition to the points described here, all information in the section “Storage” in the other supplied product manuals also applies.

If the crane is not installed immediately:

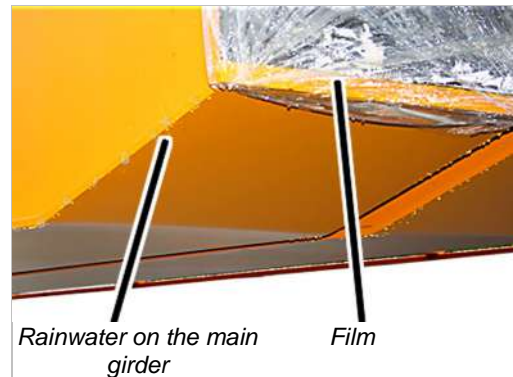

- ➔ Wipe off any rainwater.
- ➔ Cover unpainted surfaces and openings with film and mask it.
- ➔ Unpack components wrapped in film (e.g. pillars and jib arms from the jib crane). Otherwise, condensation collects under the film.
- ➔ Store unpainted metallic parts, wire rope hoists, chain hoists, electrical and electronic components in a dry, dust-free place.
- ➔ Store painted metallic parts as dry and dust-free as possible.

INSPECTION AFTER LENGTHIER STORAGE

Should the crane be installed after it has been in storage for a lengthier period:

- ➔ Perform a visual inspection of all components. They should be neither heavily soiled nor dusty.
- ➔ Inspect the paintwork. The paint should not be cracked or peeling.
- ➔ Inspect metallic parts. They should exhibit no rust.
- ➔ Inspect electrical components. Live parts (e.g. bushes, pins and terminals) should not be oxidised (e.g. discoloured or roughened surface).

INSTALLING AND CONNECTING

THIS SECTION APPLIES TO ANYONE WHO WORKS ON THE CRANE PRIOR TO ITS USE

The end user of the crane is responsible for the proper qualifications of the commissioning personnel.



DANGER TO PERSONS!

Persons can be injured if the crane is incorrectly put into operation.

If personnel other than that of the ABUS company are employed to perform the crane commissioning, it is the end user's responsibility to ensure that these persons are adequately qualified. Follow the procedures described here precisely.

Examples of qualified persons:

- Persons with comprehensive knowledge from specialist training in engineering and in the electrical systems of cranes.
- Persons with sufficient experience in the operation, installation and maintenance of cranes.
- Persons with comprehensive knowledge regarding the relevant technical rules, directives and safety regulations applicable in the respective country.
- Persons receiving regular training from ABUS.

ABUS assumes no liability for damage due to incorrectly performed commissioning work done by unqualified personnel.

ABUS recommends having the commissioning work performed by the ABUS assembly team.

INSTRUCTIONS REGARDING SAFETY: BEFORE PUTTING INTO OPERATION

Comply with the following safety instructions before beginning with putting the crane into operation:



OBSERVE THE PRODUCT MANUALS!

In addition to the points described here, all information in the section "Instructions regarding safety" in the other supplied product manuals also applies.



DANGER TO PERSONS FROM FALLS!



People can fall when working on the crane.

Falls from great heights can result in people being killed or injured.

Always use suitable lifting platforms and fall protection equipment. If the crane has a walkway on the main girder or on the wire rope hoist, a suitable lifting platform or fall protection equipment must be used for entering the walkway.

 **DANGER TO PERSONS DUE TO LACK OF BARRIERS!**



Falling objects (e.g. tools) can kill or injure people. The lifting platforms can also be overturned, e.g. by forklifts.

Adequately cordon off the operating range.

 **DANGER TO PERSONS DUE TO OTHER CRANES!**

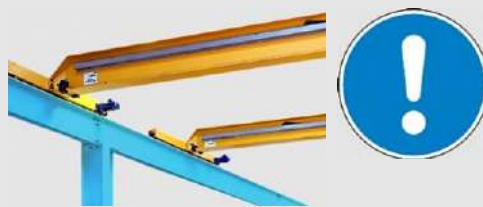

Other cranes can overturn the lifting platforms or impact the crane that is being serviced.

Switch off any other cranes using the same crane track or cranes working above or below. Secure the mains switch so that it cannot be unintentionally switched back on.

 **DANGER TO PERSONS WHEN PUTTING THE CRANE INTO OPERATION!**

Personnel working in the area may not necessarily be aware of the dangers when putting the crane into operation.

They might be hit, for example, by falling tools.

Notify personnel in the area regarding the crane being put into operation.

 **DANGER TO PERSONS FROM ELECTRIC SHOCK!**

Special expertise is required for working on electrical installations.

Without this expertise, there is a risk of electric shock.

Only trained electricians should work on the crane electrical system!

INSTRUCTIONS REGARDING SAFETY: WHEN PUTTING INTO OPERATION

Comply with the following safety instructions when putting the crane into operation:



OBSERVE THE PRODUCT MANUALS!

In addition to the points described here, all information in the section "Instructions regarding safety" in the other supplied product manuals also applies.



DANGER TO PERSONS DUE TO REMOVAL OF COVERS!



When covers (e.g. lids of panels, fan covers, motor covers, etc.) are removed, dangerous areas are no longer protected.

As a result of this people can be injured!

Remount covers after working on the crane. Do not permanently remove the covers in order to improve the cooling of components.



DANGER DUE TO BURNING PARTS!



The effects of heat from work performed on the crane (e.g. welding, open flames, flying sparks) can set parts on fire.

This can cause harmful gases to form and parts to become deformed or damaged.

Cover the parts or otherwise protect them from becoming too hot. After completing the work, inspect the condition of the parts.

INSTRUCTIONS REGARDING SAFETY: AFTER PUTTING INTO OPERATION

Comply with the following safety instructions once putting into operation has been completed:



OBSERVE THE PRODUCT MANUALS!

In addition to the points described here, all information in the section “Instructions regarding safety” in the other supplied product manuals also applies.



DANGER TO PERSONS DUE TO LOOSE PARTS!



Loose parts can fall from the crane during operation, killing or injuring people.

Remove tools and separate parts (spare parts, removed parts, etc.).

INSTALLATION OVERVIEW



OBSERVE THE PRODUCT MANUALS!

In addition to the points described here, all information in the section “Installation overview” in the other supplied product manuals also applies.

For assembly of an entire crane installation:

- ➔ In all supplied product manuals, read the sections “Installation overview” and “Checking the requirements”.
- ➔ First fulfil the requirements in the building (e.g. for overhead travelling cranes, install the crane track; for jib cranes, prepare the foundation,...).
- ➔ Then, depending on the individual components, define the order of the installation work.
- ➔ Finally, follow the respective sections for “Installing” in all product manuals according to the defined order to assemble the crane.
- ➔ If necessary: Protect the crane from rain, snow, wind or cold. See “Equipping the crane for operation in unprotected environments”, page 27.
- ➔ Next, connect the crane to the mains supply. See “Connecting the crane to the mains supply”, page 28.
- ➔ Finally, carry out the test before initial commissioning. See “Test before initial commissioning”, page 35.

EQUIPPING THE CRANE FOR OPERATION IN UNPROTECTED ENVIRONMENTS

ONLY WITH OVERHEAD TRAVELLING CRANES

Long-term usage of the crane only in weatherproof areas. Temporary use in unprotected environments (outdoors in rain, snow or cold weather) is permitted.

Should the crane be operated on a long-term or continual basis in environments without protection from the weather (outdoors, in rain, snow or cold), modifications must be made to the crane.

In windy environments, even short-term use is prohibited. If the crane is to be used in windy conditions, modifications must be made to the crane.

For the ambient conditions, see "Technical data", page 21.

PROTECTING FROM RAIN AND SNOW

Rain and snow can penetrate the electrical components of the crane and cause malfunctions (e.g. a short-circuit).

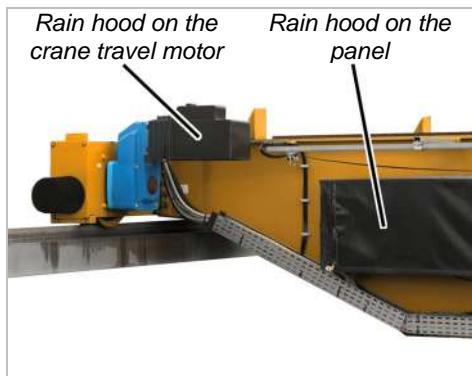

- ➔ Attach a rain hood over the crane travel motor.
- ➔ Attach a rain hood over the entire wire rope hoist.
- ➔ Attach rain hoods over all panels.

ATTACHING A WIND ANCHOR

Strong wind can cause the crane to move in an uncontrolled manner (even when switched off).

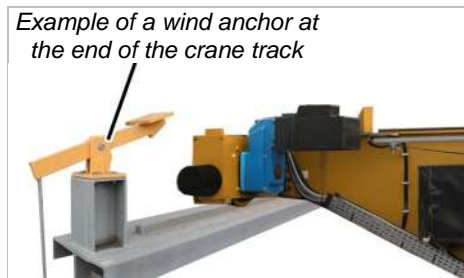

- For cranes which are operated completely outdoors: The crane must be able to be secured in a resting position (at the end of the crane track) when work is completed. A wind anchor is located at this resting position for securing the crane.
- For cranes which are operated partly outdoors: If the crane can be moved inside the building when work is finished, a wind anchor is not necessary.

ATTACHING THE WIND MEASURING SYSTEM

This section only applies to cranes which can only be safely operated up to a defined wind speed.



The crane must be equipped with a wind measuring system. The wind measuring system warns if a certain wind speed has been exceeded. The crane must then be run to its resting position (at the end of the crane track) within a specified time.

A wind anchor is located at this resting position for securing the crane. Alternatively, the wind anchor can be of a design that secures the crane at any desired position.

The corresponding wind speed up to which the crane can be operated and the time in which the crane must be able to move to its resting position are both specified in the test log book.

Only with crane with radio remote control: In order to run the crane to its resting position within the specified time, the transmitter must be located where it is easily accessible.

CONNECTING THE CRANE TO THE MAINS SUPPLY

ONLY WITH OVERHEAD TRAVELLING CRANES

OVERVIEW: ELECTRICAL CONNECTION OF THE CRANE

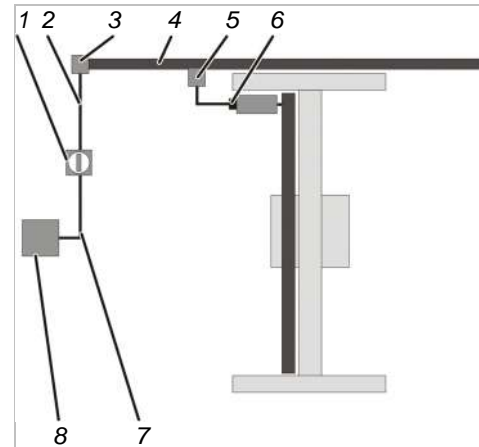

- The power supply for the crane begins at the sub-distribution (8) of the mains supply.
- From there, a line (7) runs to the mains switch (1) of the crane installation.

A mains switch is the best option for isolating the entire crane installation.

The mains switch must be secured against inadvertent switching back on.

The mains switch is usually located under the mains power supply of the crane, e.g. on the building wall or on a building support or concrete support.

- From the mains switch, the riser (2) extends to the feed unit (3).
- The feed unit connects the riser with the mains power supply (4) (usually a conductor system) of the crane.
- The mains power supply contains a mobile current collector (5) which travels with the crane along the crane track.

- The crane is connected to the mains power supply with the mains disconnecter plug (6).

This mains disconnecter plug is used to isolate the individual crane. The mains disconnecter plug can be secured against inadvertent switching back on.

Instead of the mains disconnecter plug, a separate circuit isolator (in the form a mains switch) can also be mounted on the crane panel.

The function of the mains disconnecter plug or circuit isolator can also be fulfilled by a fuse isolating link. The fuse isolating link is located in the crane control and can be secured against inadvertent switching back on.

- The line runs to the mains switch (5) of the crane.

A mains switch is the best option for isolating the entire crane.

The mains switch must be secured against inadvertent switching back on.

The mains switch is located in the pillar at operating height.

- From the mains switch, a line runs inside the pillar and is led out at the top.
For types LS and LSX: The line is led directly out of the pillar.
For type VS: The line runs in the pillar up to the slip ring (3).
- For types LS and LSX: The line out of the pillar is connected directly to the trolley power supply (4). Depending on the control, the design may include a housing with fuses for protection of the crane.

For type VS: From the slip ring, the line runs either to the jib arm panel (2) and from there to the trolley power supply (4) or directly from the slip ring to the trolley power supply. Depending on the control, the design may include a housing with fuses for protection of the crane.

ONLY WITH PILLAR SLEWING JIB CRANES

OVERVIEW: ELECTRICAL CONNECTION OF THE CRANE

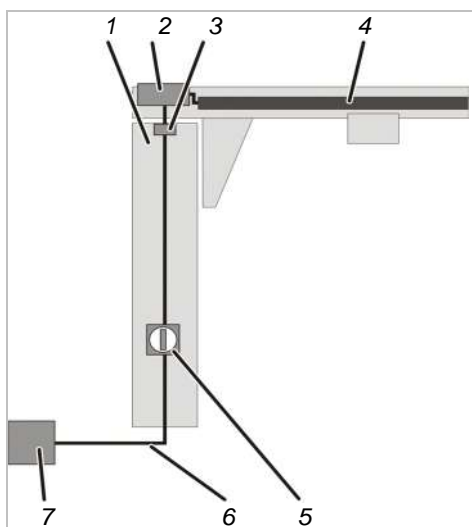

- The power supply for the crane begins at the sub-distribution (7) of the mains supply.
- From there, a line (6) runs to the pillar base of the jib crane and is led through the foundation into the pillar (1).

ONLY WITH WALL JIB CRANES

OVERVIEW: ELECTRICAL CONNECTION OF THE CRANE

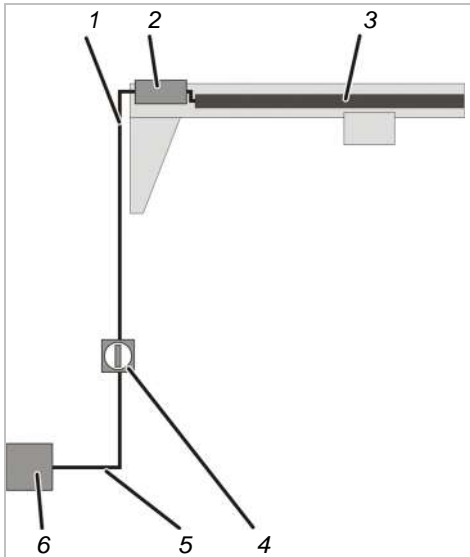

- The power supply for the crane begins at the sub-distribution (6) of the mains supply.
- From there, a line (5) runs to the mains switch (4) of the crane.

A mains switch is the best option for isolating the entire crane.

The mains switch must be secured against inadvertent switching back on.

The mains switch is usually located under the crane, e.g. on the building wall or on a building support or concrete support.

- From the mains switch, the riser (1) extends to the crane.
- For types LW and LWX: The line is connected directly to the trolley power supply (4). Depending on the control, the design may include a housing with fuses for protection of the crane.

For type VW: The line runs either to the jib arm panel (2) and from there to the trolley power supply (4) or directly to the trolley power supply. Depending on the control, the design may include a housing with fuses for protection of the crane.

ONLY WITH HB CRANE TYPES MONORAIL SYSTEM AND DOUBLE-RAIL SYSTEM

OVERVIEW: ELECTRICAL CONNECTION OF THE HB CRANE

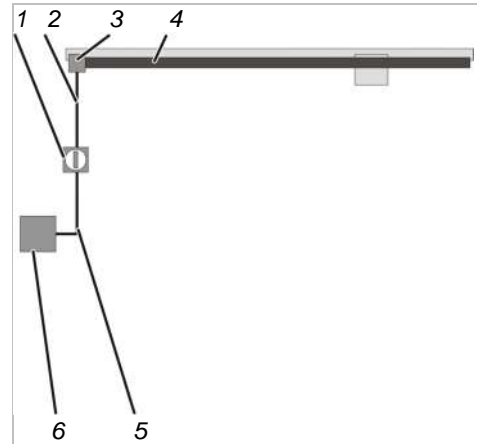

- The power supply for the HB crane begins at the sub-distribution (6) of the mains supply.
- From there, a line (5) runs to the mains switch (1) of the HB crane installation.

A mains switch is the best option for isolating the entire HB crane installation.

The mains switch must be secured against inadvertent switching back on.

The mains switch is usually located under the mains power supply of the HB crane, e.g. on the building wall or on a building support or concrete support.

- From the mains switch, the riser (2) extends to the feed unit (3).
- There the line is connected with the trolley power supply (4). Depending on the control, the design may include a housing with fuses for protection of the crane.

**ONLY WITH HB CRANE TYPES
SINGLE-GIRDER CRANE AND
DOUBLE-GIRDER CRANE**

**OVERVIEW: ELECTRICAL
CONNECTION OF THE HB CRANE**

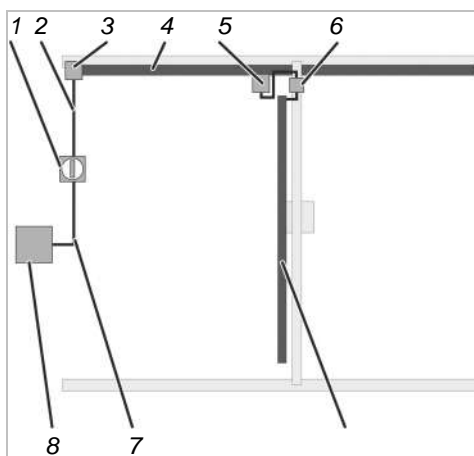

- The power supply for the HB crane begins at the sub-distribution (8) of the mains supply.
- From there, a line (7) runs to the mains switch (1) of the HB crane installation.
A mains switch is the best option for isolating the entire HB crane installation.
The mains switch must be secured against inadvertent switching back on.
The mains switch is usually located under the mains power supply of the HB crane, e.g. on the building wall or on a building support or concrete support.
- From the mains switch, the riser (2) extends to the feed unit (3).
- The feed unit connects the riser with the mains power supply (4) of the crane.
- For conductor systems: The mains power supply contains a mobile current collector (5) which travels with the HB crane along the HB crane runway.
For festoon cable systems: The line of the mains power supply hangs in loops on the HB crane runway and is towed by the HB crane.

- The HB crane is connected to the mains power supply.
If the HB crane installation consists of a single HB crane, the mains power supply is connected directly to the HB crane. Depending on the control, the design may include a housing with fuses for protection of the crane.
- If the HB crane installation consists of several HB cranes, there is a circuit isolator on the crane.
This circuit isolator is used to isolate the individual HB cranes. The circuit isolator must be secured against inadvertent switching back on. Depending on the control, the design may include a housing with fuses for protection of the crane.

**ONLY WITH MOBILE GANTRY
CRANES**

**OVERVIEW: ELECTRICAL
CONNECTION OF THE CRANE**

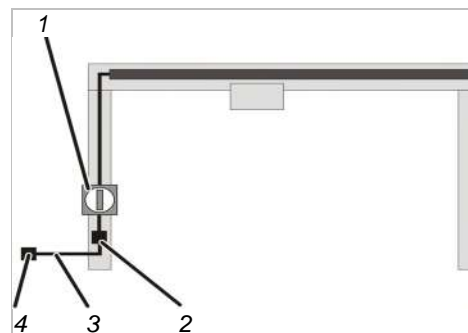

- The power supply for the crane begins at a three-phase socket (4).
- From there, a suitable line with a CEE plug (3) runs to the mains disconnector plug (2) of the crane.
- From there, a line runs to the mains switch (1) of the crane.
The mains switch is located on one of the portal legs on the crane.

ONLY WITH SINGLE-RAIL TROLLEY TRACKS

OVERVIEW: ELECTRICAL CONNECTION OF THE CRANE

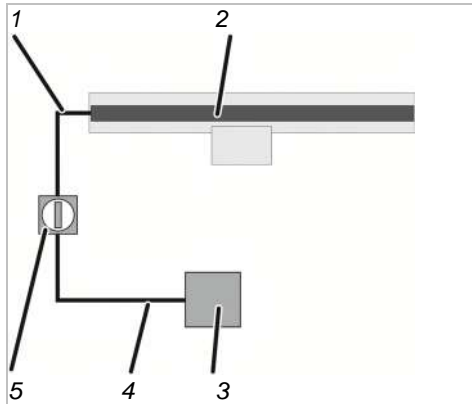

- The power supply for the crane begins at the sub-distribution (3) of the mains supply.
- From there, a line (4) runs to the mains switch (5) of the crane.

A mains switch is the best option for isolating the entire crane.

The mains switch must be secured against inadvertent switching back on.

The mains switch is usually located under the crane, e.g. on the building wall or on a building support or concrete support.

- From the mains switch, the riser (1) extends to the crane.
- There the line is connected to the trolley power supply (2).

ONLY WITH SOLO CHAIN HOISTS

OVERVIEW: ELECTRICAL CONNECTION OF THE CRANE

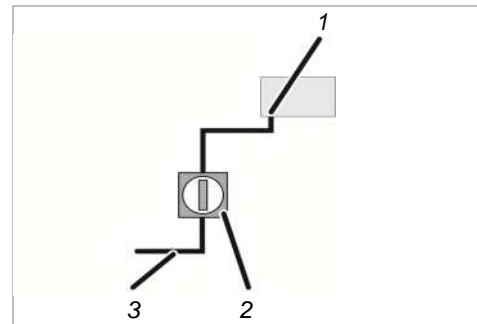

- The power supply for the solo chain hoist is connected according to the on-site conditions in the building.
- The line (3) must have a mains switch as general mains switch for the entire crane installation (2) or a plug-in connection as a mains disconnecter plug.

The bayonet coupling (1) on the chain hoist cannot be secured against switching back on and is therefore not suitable as a mains disconnecter plug.

ONLY WITH SOLO WIRE ROPE HOISTS

OVERVIEW: ELECTRICAL CONNECTION OF THE CRANE

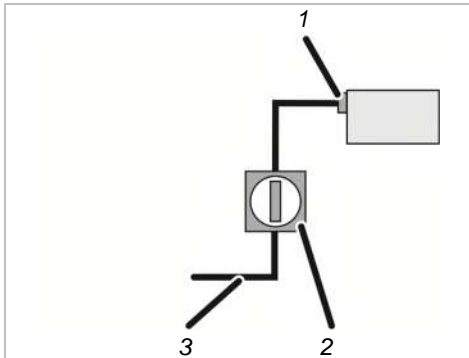

- The power supply for the solo wire rope hoist is connected according to the on-site conditions in the building.
- The mains disconnecter plug (1) on the wire rope hoist can be secured against inadvertent switching back on.
- However, it is still recommended that the line (3) have a mains switch as general mains switch (2) for the entire crane installation.

CHECKING THE ON-SITE MAINS SUPPLY

➔ For cranes without voltage adapting transformer: Compare the operating voltage and mains frequency of the crane with the mains voltage and frequency of the local mains supply.

The operating voltage and mains frequency are specified on the type plates on the crane and in the test log book.

Operating voltage and mains voltage as well as mains frequency must be matched for one another.

➔ For cranes with voltage adapting transformer: The mains voltage of the local mains supply must be converted to the operating voltage of the crane by a voltage adapting transformer.

Compare the operating voltage and mains frequency at the input of the voltage adapting transformer with the mains voltage and frequency of the local mains supply.

CONNECTING THE CRANE



DANGER TO PERSONS FROM ELECTRIC SHOCK!

There are high voltages when the crane is connected.

These could kill or injure people.

Work on electrical systems and components may only be performed by a qualified electrician when the system is voltage-free.

➔ Lay the lines, attach the mains switch and connect the crane.

CHECKING THE ROTARY FIELD

The crane may only be operated on a 3-phase mains supply with a clockwise rotary field.

- ➔ Unlock the emergency stop switch.
- ➔ Press the 'Lift' button halfway.
 - The load hook must run slowly upward or remain stopped (if the top emergency limit switch has already been triggered).

If the load hook travels downwards instead:

- The phases in the mains supply have been interchanged.
- ➔ Correct the interchanged phases.

If possible, correct the phases at the point where they were interchanged. Only in exceptional cases should the phases be interchanged again directly on the power line.

CHECKING PROTECTIVE CONDUCTORS

All components of the crane are connected with the protective conductor of the local mains supply. These connections are made through plug-in connections, cable lugs and similar means.

For all protective conductor connections which have been established during the assembly of the crane:

- ➔ Carry out a visual inspection.

The protective conductors must be uninterrupted and correctly connected.

Examples of protective conductor connections:



Bush multipoint connector in prong terminal block



Screening clamp connection in connector housing



Cable lug in connector housing

ENSURING ELECTROMAGNETIC COMPATIBILITY (EMC)

Electrical devices and lines normally generate electromagnetic fields. These fields can negatively affect other devices and cause malfunctions. To best avoid such disturbances, certain basic principles must be observed when working with electrical equipment.

For any electrical work performed on the crane:

In order for the crane to operate without faults, all electrical components and all connection cables must be installed by professionals.

Observe the following points amongst others:

- Do not lay signal lines together with current-conducting lines.
- With frequency converters: guide connection cables for braking resistance and connection cables for motors through the cable fittings in the panel and lay them in a direct path to the frequency converter.
- Lay the shields of shielded cables over a wide area and earth them.
- Do not twist, braid or solder shields. Instead, use the supplied installation material.
- Earth the unused wires of cables in the panel.

TEST BEFORE INITIAL COMMISSIONING

Before the crane can be put into operation for the first time, a test must be carried out. The end user is responsible for this test prior to initial commissioning.

REQUIREMENTS FOR THE EXAMINER

The end user of the crane is responsible for the proper qualifications of the examiner.



DANGER TO PERSONS!

Persons can be injured if the test is performed incorrectly.

If personnel other than that of the ABUS company are employed to perform the test, it is the end user's responsibility to ensure that these persons are adequately qualified.

Examples of qualified persons:

- Persons with comprehensive knowledge from specialist training in engineering and in the electrical systems of cranes.
- Persons with sufficient experience in the operation, installation and maintenance of cranes.
- Persons with comprehensive knowledge regarding the relevant technical rules, directives and safety regulations applicable in the respective country.
- Persons receiving regular training from ABUS.

OVERVIEW: INSPECTING THE CRANE

The qualified person inspecting the crane is responsible for the type and scope of the test.

The items to be checked in the following list represent a general overview regarding the scope of testing of ABUS cranes. Depending on the type, not all components will be present on the crane.

The decision as to whether the crane is in perfect condition may be made only by the person inspecting the crane. Any inadequacies, if found, must be eliminated. The examiner decides whether the crane has to be tested again afterward.

If locally applicable regulations specify further tests, these are likewise to be carried out.

The examiner tests the operational crane. In doing so, it must be ensured that no one is subjected to avoidable dangers.

At least the following points must be checked:

- ➔ Check the general condition. The components of the crane installation may not be damaged or rusted, or exhibit any other dangerous material changes.
- ➔ Check the condition of the supporting structure. It should not exhibit any damage.
- ➔ Check that the crane has been correctly installed and connected. It must be installed and connected in accordance with this and other product manuals.
- ➔ Check the hoist drive, trolley drive and crane travel drive. They must be functioning flawlessly. For the test for switching on, see the product manual "Operating the ABUS crane".
- ➔ Test the brakes on the hoist drives, trolley drives and crane travel drives. They must be functioning flawlessly. For the test for switching on, see the product manual "Operating the ABUS crane".
- ➔ Check the hoist limit switches (switching points for safety limit switches and emergency limit switches). The hoist must switch off at the appropriate switching points.
- ➔ If available: Check the operating limit switches. The hoist must switch off at the appropriate switching points.
- ➔ Check the travel limit switch. The crane travel drives and the trolley drives must switch off at the appropriate switching points.
- ➔ Check screws. All screws must be tightened and secured. If they are not, tighten the screws with the appropriate tightening torque and secure them.
- ➔ If available: Check warning devices. They must function as intended.
- ➔ Check the overload protection (e.g. load indicator system LIS or friction clutch). It must function as intended.

- ➔ Check all other safety devices on the crane. They must function as intended.
- ➔ If available: Check the condition of the wind anchor. It must function as intended.
- ➔ Check the signage. The required signs on the crane must be present and legible. Otherwise, replace the signs.
- ➔ Perform a static test of the maximum load capacity.
Test using a test load with 1.25 times the maximum load capacity of the crane.
- ➔ Perform a dynamic test of the maximum load capacity.
Test using a test load with 1.1 times the maximum load capacity of the crane.
- ➔ Only if necessary: Perform additional country-specific tests.
- ➔ Only within the EU: Check whether there is a Declaration of Conformity or a Declaration of Incorporation.

CHECKING THE TEST LOG BOOK

Also in countries which do not require a test log book, it is recommended to document the test in the test log book.

- ➔ Check the test log book:
 - It must be available
 - It must be within easy reach of all persons working on or with the crane.
 - It must be clearly identified as belonging to the crane.
 - All tests carried out (e.g. test before initial commissioning, regular inspections, tests of the crane track, etc.) must be documented.

INSPECTION

THIS SECTION APPLIES TO ANYONE WHO INSPECTS AND ACCEPTS THE CRANE IN ACCORDANCE WITH OCCUPATIONAL HEALTH AND SAFETY REQUIREMENTS

The crane must be regularly inspected in order to guarantee safe operation. The end user is responsible for this regular inspection.

AT THE START

TEST INTERVALS

The regular inspection is performed at least once annually.

Under certain conditions, more frequent regular inspections may be necessary. Reasons include:

- Frequent operation at the load capacity
- Working in multiple shifts
- Frequent use
- Dusty or chemically aggressive environment

The end user is responsible for checking the requirements and determining the test intervals. ABUS will gladly assist you if questions arise.

REQUIREMENTS FOR THE EXAMINER

The end user of the crane is responsible for the proper qualifications of the examiner.



DANGER TO PERSONS!

Persons can be injured if the test is performed incorrectly.

If personnel other than that of the ABUS company are employed to perform the test, it is the end user's responsibility to ensure that these persons are adequately qualified.

Examples of qualified persons:

- Persons with comprehensive knowledge from specialist training in engineering and in the electrical systems of cranes.
- Persons with sufficient experience in the operation, installation and maintenance of cranes.
- Persons with comprehensive knowledge regarding the relevant technical rules, directives and safety regulations applicable in the respective country.
- Persons receiving regular training from ABUS.

MAINTENANCE RESULTING FROM THE REGULAR INSPECTION

The regular inspection occurs in many countries because of national requirements and distinctions that must be observed accordingly.

In addition, the regular inspection is also the basis for maintenance work on the crane which is prescribed by ABUS as manufacturer.

If defects, wear or similar issues are noticed, this is the time to perform the corresponding maintenance work.

Based on this requirement, it can also be useful to adapt the test intervals (see "At the start", page 38) or to inspect components subject to especially high load (see "Testing of components subject to especially high stress", page 50).

As a manufacturer's requirement, the regular inspection must therefore also be performed by the end user if national requirements do not demand any regular inspection or these inspections are not as comprehensive.

SCOPE OF THE INSPECTION

The qualified person inspecting the crane is responsible for the type and scope of the test.

OVERVIEW: INSPECTING THE CRANE



OBSERVE THE PRODUCT MANUALS!

In addition to the points described here, all information in the section “Scope of the inspection” in the other supplied product manuals also applies.

The items to be checked in the following list represent a general overview regarding the scope of testing of ABUS cranes. Depending on the type, not all components will be present on the crane.

The decision as to whether the crane is in perfect condition may be made only by the person inspecting the crane. Any inadequacies, if found, must be eliminated. The examiner decides whether the crane has to be tested again afterward.

If locally applicable regulations specify further tests, these are likewise to be carried out.

General overview of the points to be inspected:

- ➔ Check the general condition. The components of the crane installation may not be damaged or rusted, or exhibit any other dangerous material changes.
- ➔ Check the condition of the supporting structure. It should not exhibit any damage.
- ➔ Check that the crane has been correctly installed and connected. It must be installed and connected in accordance with this and other product manuals.
- ➔ Check the hoist drive, trolley drive and crane travel drive. They must be functioning flawlessly. For the test for switching on, see the product manual “Operating the ABUS crane”.
- ➔ Test the brakes on the hoist drives, trolley drives and crane travel drives. They must be functioning flawlessly. For the test for switching on, see the product manual “Operating the ABUS crane”.

- ➔ Check the hoist limit switches (switching points for safety limit switches and emergency limit switches). The hoist must switch off at the appropriate switching points.
- ➔ If available: Check the operating limit switches. The hoist must switch off at the appropriate switching points.
- ➔ Check the travel limit switch. The crane travel drives and the trolley drives must switch off at the appropriate switching points.
- ➔ Check screws. All screws must be tightened and secured. If they are not, tighten the screws with the appropriate tightening torque and secure them.
- ➔ If available: Check warning devices. They must function as intended.
- ➔ Check the overload protection (e.g. load indicator system LIS or friction clutch). It must function as intended.
- ➔ Check all other safety devices on the crane. They must function as intended.
- ➔ If available: Check the condition of the wind anchor. It must function as intended.
- ➔ Check the signage. The required signs on the crane must be present and legible. Otherwise, replace the signs.
- ➔ Check weld seams. They should not be cracked or broken.
- ➔ Check the condition of the paintwork. It should not be scratched or peeling. Otherwise, remove peeling paint and touch up the paint coat.
- ➔ Check the load hook. See “Checking the load hook”, page 41.
- ➔ Check the hoist drive, trolley drive and crane travel drive for tightness. The drives should not exhibit any exterior cracks or traces of leaked lubricant.
- ➔ Check the air gap and brake lining thickness of the brakes on the hoist drives, trolley drives and crane travel drives. The air gap width must match that specified in the corresponding product manual. The brake lining thickness must match that specified in the respective product manual. Otherwise, adjust the air gap and, if possible, change the brake rotor with brake lining or the fan blade with brake lining.

If the width of the air gap is still within the permitted range but the wear behaviour indicates the air gap will be wider than permitted before the next inspection: The brake must now be adjusted accordingly or the exchange of the brake rotor with brake lining or fan blade with brake lining must be done now.

- ➔ If necessary: Check the load capacity.
Check the load capacity using a test load approaching the maximum load capacity of the crane.
- ➔ Check the lubrication of all moving parts. See “Lubricants”, page 59.
- ➔ If applicable: Inspect conductor system. See “Inspecting the conductor system”, page 44.

ONLY WITH WIRE ROPE HOISTS

- ➔ Inspect the wire rope. See “Inspecting the wire rope”, page 45.
- ➔ Check the wire rope (on the cable drum and on the fixed point crosshead) and check the cable guide. The components should not be damaged, heavily worn, broken or loose.
- ➔ Check the wheel flange wear of the wheels on the wire rope hoist.
- ➔ Check the braking distance of the trolley drive.
- ➔ Check the diameter of the guide rollers on the wire rope hoist.
- ➔ Check the wheel diameters on the wire rope hoist.
- ➔ Check the condition of the safety buffer on the wire rope hoist.
- ➔ Check the condition of the bottom block (visual inspection).
- ➔ Check the edge protection on the bottom block (visual inspection).
- ➔ Check the rope wedge protrusion.

ONLY WITH CHAIN HOISTS

- ➔ Inspect the chain. See “Inspecting the chain”, page 46.
- ➔ Check additional components. See the product manual for the chain hoist.

ONLY WITH CRANES FOR OPERATION IN UNPROTECTED ENVIRONMENTS

- ➔ Check rain hoods and similar covers for secure fit.
- ➔ Check panels and connector housings. No water should have penetrated and the housings must be sealed.
- ➔ Check the electrical system. Contacts and cables should not exhibit any areas of corrosion.
- ➔ Check the lubricant in the bearings. The bearings should not be eroded or exhibit corrosion.

- ➔ Check the test log book. See “Checking the test log book”, page 49.
- ➔ Determine the already elapsed portion of the theoretical service life. See “Checking the remaining service life”, page 48.
- ➔ Only if necessary: Perform additional country-specific tests.
- ➔ Document the test. See “Documenting the test”, page 49.

Also in countries which do not require a test log book, it is recommended to document the test in the test log book.

CHECKING THE LOAD HOOK

ONLY WITH CHAIN HOISTS

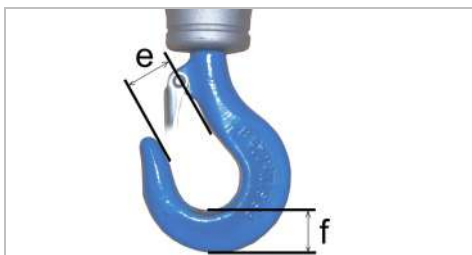

- ➔ Measure the widening 'e' of the load hook.
- ➔ Measure the base height 'f' of the load hook.
- ➔ The measured values should neither exceed nor fall short of the values in the table.

Size of load hook	Type of load hook	Max. widening 'e' [mm]	Min. base height 'f' [mm]	Material
012	single	26.4	18.1	STE 355
025	single	30.8	22.8	STE 355
05	single	37.5	29.5	34 CrMo 4
1	single	44.0	38.0	34 CrMo 4
1.6	single	49.5	45.6	34 CrMo 4

- ➔ If the load hook has been widened to a greater degree than is allowed or if the base height is below the permissible limit, replace the load hook.
- ➔ If the load hook is deformed (even if within the measurements given above): Inspect the surface for cracks.

ONLY WITH WIRE ROPE HOISTS

CHECKING FOR EASE OF MOVEMENT

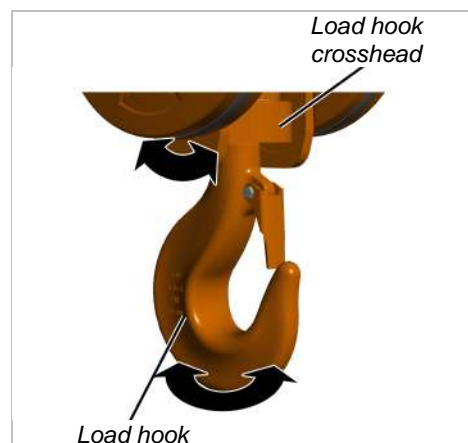

- ➔ Rotate the load hook backwards and forwards.
The load hook must be easy to move and freely rotatable.
- ➔ Slew the load hook backwards and forwards at the load hook crosshead.
The load hook crosshead must be freely slewable.
- ➔ If the load hook is not easy to move or freely rotatable or slewable, it must be repaired.
ABUS Service will gladly provide assistance if needed. See "ABUS Service", page 58.

INSPECTING THE BRACKET ON THE BOTTOM BLOCK

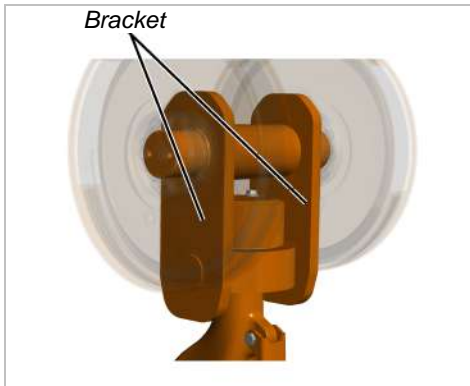

- ➔ Inspect the brackets. They must not exhibit any cracking, deformation or other signs of damage.
- ➔ If the brackets are deformed or damaged in any other way, they must be replaced.

MEASURING DEFORMATION AND WEAR OF THE LOAD HOOK

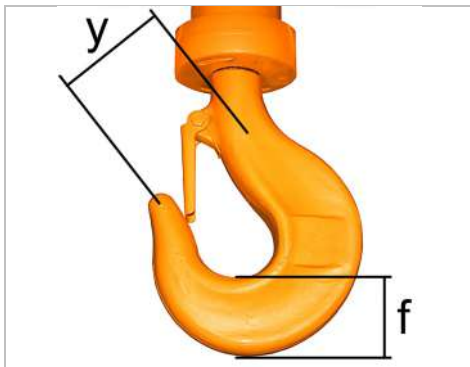

- ➔ Measure the distance 'y' between the two stamped markings.
- ➔ Read the reference distance for 'y' from the test log book or, if applicable, from the load hook itself.

The measured distance 'y' must not be greater than 1.1 times the reference distance 'y'.

With ramshorn hooks, the distances 'y1' and 'y2' from the engraved marking on the tip of the load hook to the marking on the shaft must each be measured and compared separately.

- ➔ Measure the base height 'f' of the load hook.
- ➔ Compare the measured value with the table.

The measured base height 'f' must not be smaller than given in the table. The table specifies the minimum base height.

Size of load hook	Type of load hook	Min. base height 'f' [mm]
1	Normal hook	38
1.6	Normal hook	45.6
2.5	Ramshorn hook	47.5
2.5	Normal hook	55.1
4	Ramshorn hook	57
4	Normal hook	63.7
6	Ramshorn hook	71.3
6	Normal hook	80.8
8	Ramshorn hook	80.8
8	Normal hook	90.3
10	Ramshorn hook	90.3
10	Normal hook	100.7
12	Ramshorn hook	100.7
12	Normal hook	112.1
16	Ramshorn hook	112.1
16	Normal hook	125.4
20	Ramshorn hook	125.4
20	Normal hook	142.5
25	Ramshorn hook	142.5
25	Normal hook	161.5
32	Ramshorn hook	161.5
32	Normal hook	180.5
40	Ramshorn hook	180.5
40	Normal hook	201.4

- ➔ If the load hook has been widened to a greater degree than is allowed or if the base height is below the permissible limit, replace the load hook.

Do not carry out any repair welding (e.g. build-up welding) on the load hook or on the load hook nut.

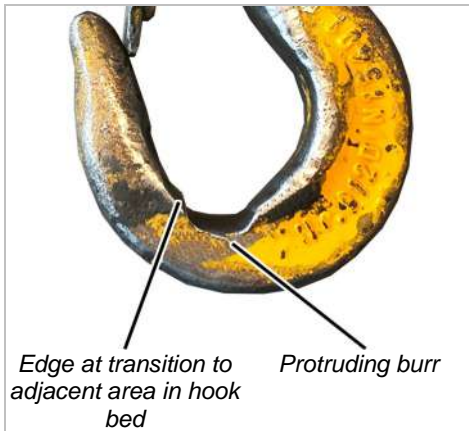

- ➔ Check the wear surfaces in the hook bed. They must merge gradually with the surrounding surfaces. They must not have any sharp score marks and edges or other surface faults.
- ➔ Inspect the edges. The side edges on the hook should not have any exterior protruding burrs or similar surface faults.
- ➔ If the wear surfaces or side edges do have sharp score marks or edges, these may be smoothed (e.g. filed). The limit values for base height given above must be observed even after smoothing.

INSPECTING THE LOAD HOOK SURFACE

- ➔ Inspect the load hook surface. It must not have any faults, cracks or corrosion.
- ➔ If the surface of the load hook is to any extent not OK, disassemble the load hook and inspect the surface of the hook shank. It must not have any faults, cracks or corrosion.

INSPECTING THE ANTI-ROTATION DEVICE OF THE LOAD HOOK NUT

With load hooks with anti-rotation device through tensioner sleeve:

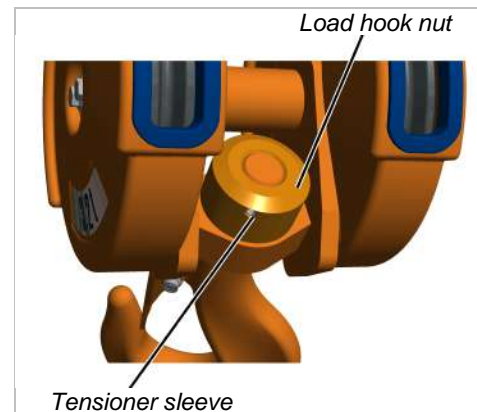

- ➔ Tilt the load hook until the anti-rotation device is clearly visible.
- ➔ Inspect the anti-rotation device. The locking pin must be present, may not be damaged or broken and it must sit securely.
- ➔ If the locking pin is missing or damaged, it must be replaced.

With load hooks with anti-rotation device through locking plate:

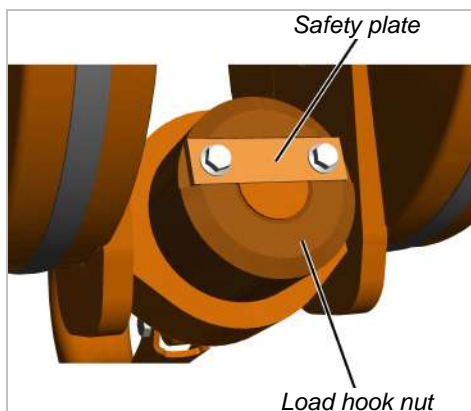

- ➔ Tilt the load hook until the anti-rotation device is clearly visible.
- ➔ Inspect the anti-rotation device. The safety plate must be present, undamaged and fit securely.
- ➔ If the locking plate is missing or damaged, it must be replaced.

INSPECTING THE HOOK SAFETY LATCH

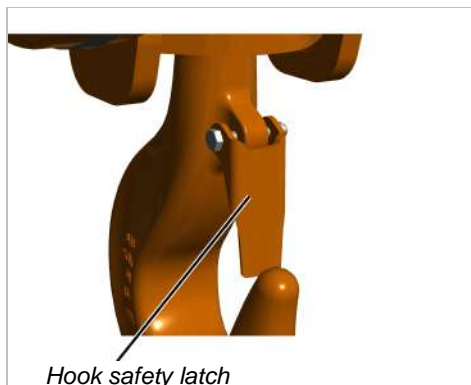

- ➔ Inspect the hook safety latch. It must be present, functional and easy to move, and must not be deformed or damaged in any other way.
- ➔ If the hook safety latch is missing, damaged or not working properly, it must be replaced.

INSPECTING THE CONDUCTOR SYSTEM

ONLY WITH CONDUCTOR SYSTEM AS MAINS POWER SUPPLY OR TROLLEY POWER SUPPLY

This section is only applicable if a conductor system is used as the mains power supply or the trolley power supply.



DANGER TO PERSONS FROM ELECTRIC SHOCK!

There are high voltages of the conductor system. These could kill or injure people.

Before performing any work on the conductor system, switch off the crane and secure it against being switched back on.



DANGER TO PERSONS DUE TO FAILURE OF PROTECTIVE CONDUCTOR!

The protective conductor is also connected to the crane through the conductor system. If the conductor system and the current collector are not carefully inspected and maintained, it is possible that the protective conductor may be broken.

Regularly check the conductor system and current collector.

INSPECTING THE CONDUCTOR SYSTEM

- ➔ Inspect the sections of the conductor system, the joints of the sections and the suspensions. The parts should not be broken, deformed or otherwise damaged.
- ➔ Inspect the inside of the conductor system. It should not be heavily soiled (e.g. due to rubbing of the carbon strip or dirt in the surroundings).
- ➔ Inspect the sections of the conductor system. The surface of current-conducting rails must be smooth.

- ➔ If the conductor system is heavily soiled or the surface of the rails is not smooth, blow off with compressed air or clean with a cleaning trolley.

The cleaning trolley is supplied through ABUS Service. See "ABUS Service", page 58.

INSPECTING CURRENT COLLECTORS

- ➔ Check the running characteristics of the current collector. It must run smoothly and without resistance in the conductor system.
- ➔ Take the current collector out of the conductor system.
- ➔ Check the thickness of the carbon strips. The carbon strips should not show more wear than is permissible.

How much wear the carbon strips are allowed to have is either specified on the current collector (according to the conductor system) or the maximum wear is indicated by a marking on the carbon strip itself.
- ➔ Check the wheels of the current collector. They must run smoothly and be free of damage.

- ➔ If the current collector does not run smoothly or the carbon strips are more heavily worn than is allowed, replace the current collector completely, or (if possible) replace the carbon strips.

INSPECTING THE WIRE ROPE

ONLY WITH WIRE ROPE HOISTS

- ➔ Inspect the entire wire rope for damage. The damage shown here or any similar damage should not be detectable on the wire rope.

Examples of damage:



The joining of the wire rope has opened. The inner strands of the wire rope are visible.



Loops have formed in the wire rope.



There is a kink in the wire rope. This results from violent external forces being applied to the wire rope.



The wire rope is flattened at one point. This results from the wire rope being pinched.



A bird cage has formed in the wire rope. This results from violent untwisting of the wire rope.



The wire rope has a corkscrew-type deformation.

- Check the entire wire rope for broken wires. The wire rope must not exhibit more broken wires in a length of 6 times its diameter or 30 times its diameter than is specified for these lengths on the ABUS manufacturer's certificate for wire ropes in the test log book.

Examples of broken wires:



Multiple broken wires. Broken wires are signs of normal wear of the wire rope. They occur when the wire rope is bent on the reels under load.



Broken wire with protruding wire end.

- If damage such as that pictured or similar damage is detected on the wire rope, replace the wire rope with a new one.
- If the wire rope has broken wires, but not exceeding the permissible number, shorten the test interval until the next test.
- If the wire rope has more broken wires than permitted, replace the wire rope with a new one.

INSPECTING THE CHAIN

ONLY WITH CHAIN HOISTS

- Inspect the condition of the chain (lubrication, corrosion, surface damage) and check the chain's wear (length of the chain over 11 chain links). See the product manual for the chain hoist.

Examples of damage:



The chain link is heavily worn.



The chain link is mechanically damaged.

BASICS FOR DETERMINING THE REMAINING SERVICE LIFE

To avoid accidents with the crane due to wear and age, it is essential to always ensure that the hoist operates within a safe working period.

ACTUAL HOURS OF USE (S) AND THEORETICAL SERVICE LIFE (D)

The hoist operates within a safe operating period if the actual hours of use (S) are fewer than the number of hours representing the theoretical service life (D).

The theoretical service life (D) is determined and specified by ABUS according to the generally accepted engineering standards. The theoretical service life is given in full-load hours. A full-load hour is defined as the hoist having operated at its maximum load capacity for one hour.

The actual hours of use (S) of the hoist must be determined by the end user. The value must be determined based on the operating hours, the load spectrum and additional factors.

LOAD SPECTRUM

In order to also take into account the operating phases of the hoist in which the hoist was not operating at maximum load capacity, but instead lifted lesser loads, there are four different load spectrums (Km). The load spectrum (Km) is a mathematical factor. It specifies how great a load is actually placed on the hoist during operation.

There are four load spectrums

- Light (Km = 0.5)
- Medium (Km = 0.5 to 0.63)
- Heavy (Km = 0.63 to 0.8)
- Very heavy (Km = 0.8 to 1.0)

In the light load spectrum, for example, the hoist often runs with an empty load hook and transports light loads (in relation to its maximum load capacity). In the very heavy load spectrum, for example, the hoist seldom runs with an empty load hook and nearly always transports loads at its maximum load capacity.

The load spectrum thus specifies the degree to which the hoist is subjected to its maximum load capacity or only to lesser operating demands.

Examples:

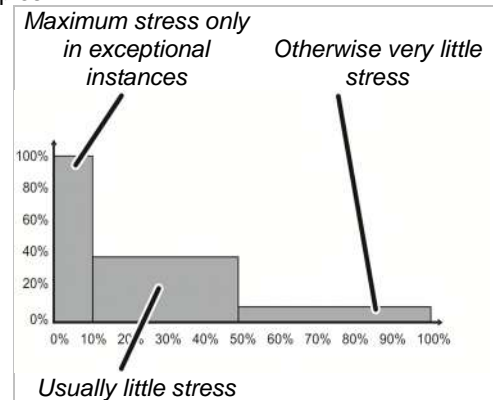

Example of the "light" load spectrum (Km = 0.5)

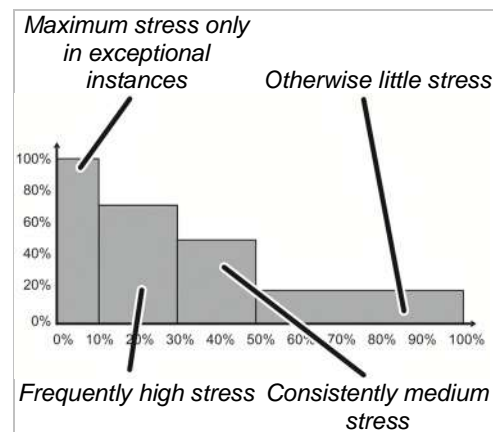

Example of the "medium" load spectrum (Km = 0.5 to 0.63)

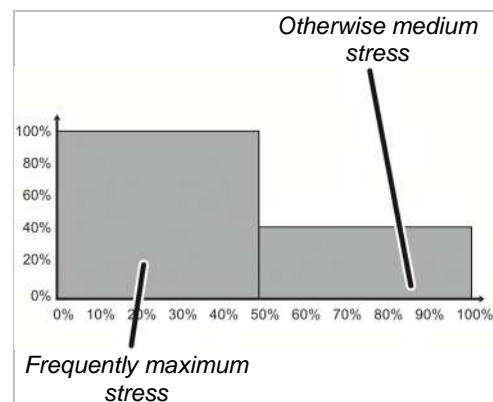

Example of the "heavy" load spectrum (Km = 0.63 to 0.8)

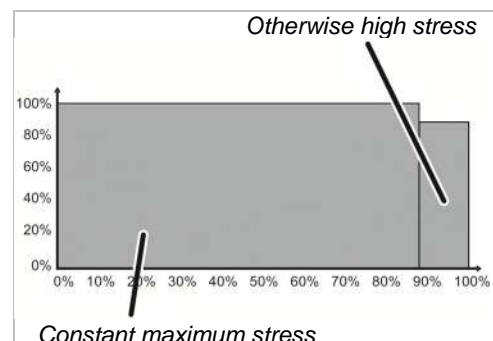

Example of the "very heavy" load spectrum (Km = 0.8 to 1.0)

CHECKING THE REMAINING SERVICE LIFE

The actual hours of use (S) must be documented within the scope of a regular inspection at least once yearly.

The remaining service life will continue to be evaluated during the regular inspection. This is done by determining whether the actual hours of use (S) are still fewer than the number of hours representing the theoretical service life (D).

If the remaining service life is very limited or zero, the hoist may no longer be used. In this case, a general overhaul of the entire hoist by ABUS as manufacturer is required.

DETERMINING THE REMAINING SERVICE LIFE

- ➔ The exact procedure for determining the remaining service life can be found in FEM 9.755.

Overview:

- ➔ The classification according to FEM for the hoist drive can be read on the type plate.
- ➔ Read the corresponding theoretical service life D in the table.

Classification according to FEM Load spectrum	1Bm	1Am	2m	3m	4m
Light (Km = 0.5)	3200	6300	12500	25000	50000
Medium (Km = 0.5 to 0.63)	1600	3200	6300	12500	25000
Heavy (Km = 0.63 to 0.8)	800	1600	3200	6300	12500
Very heavy (Km = 0.8 to 1.0)	400	800	1600	3200	6300

- ➔ Determine the actual hours of use.
This can be done using a load population recorder, an operating hours counter, through documentation of usage or by estimating.
- ➔ Compare the theoretical service life (D) and the determined actual hours of use (S).
- ➔ The calculated remaining service life of the hoist is to be documented in the test log book.
- ➔ If the theoretical service life of the hoist has been reached: Take the hoist out of service and have ABUS perform a general overhaul.

CHECKING THE TEST LOG BOOK

Also in countries which do not require a test log book, it is recommended to document the test in the test log book.

- ➔ Check the test log book:
 - It must be available
 - It must be within easy reach of all persons working on or with the crane.
 - It must be clearly identified as belonging to the crane.
 - All tests carried out (e.g. test before initial commissioning, regular inspections, tests of the crane track, etc.) must be documented.

DOCUMENTING THE TEST

Also in countries which do not require a test log book, it is recommended to document the test in the test log book.



- ➔ Document the result of the entire test in the test log book.
 - Type and scope of the test
 - Items of the test still to be evaluated
 - Inadequacies detected
 - Assessment of whether the crane may be operated
 - Decision on whether a re-check is necessary

The test log book and the complete documentation for the crane must be within easy reach of all persons working on or with the crane.

- ➔ Mark the regular inspection as having been performed with a label clearly visible from the outside, e.g. through an inspection sticker.

ACCEPTANCE TEST AFTER SUBSTANTIAL CHANGES

Once substantial changes have been made, these require an acceptance test.

This test is identical to the test before initial commissioning. See "Test before initial commissioning", page 35.

The test is only necessary on the parts of the crane that have undergone substantial change.

Examples of substantial changes are:

- Changing the power supply
- Replacement of trolleys
- Converting or modifying the travel drive or hoist drive
- Increasing the maximum load capacity of a crane installation
- Extension of a crane track
- Using cranes on different crane tracks
- Welding on load-bearing structural elements
- Design modifications to a supporting structure
- Conversion of components of the supporting structure. This includes the crane track, the mountings, the building beams, the building supports, the concrete girders and the concrete supports.
- Change of the operating conditions of the crane installation in relation to the classification according to FEM.
- Conversion to a different type of control (e.g. radio remote control).
- Changing the mode of operation in regard to the operating time class and the load spectrum (e.g. switching from single-shift operation to multiple-shift operation).

TESTING OF COMPONENTS SUBJECT TO ESPECIALLY HIGH STRESS

During operation of the crane, situations can arise in which the individual components are subject to higher stress than expected.

This can result in damage that might be detected too late in the regular inspection at the previously specified test intervals.

Nevertheless, safe operation must be ensured for these components as well.

It may thus be necessary to check individual components of a crane or entire modules especially frequently. These additional tests are then regularly required at briefer intervals in addition to the regular inspection.

Examples:

- The risk assessment has revealed that certain components (e.g. brakes or wire ropes) are subject to especially high stress.

Example: In a food-processing facility, a wire rope is not permitted to be lubricated for reasons of hygiene. The risk assessment clearly shows that this wire rope is subject to especially high stress. It must therefore be checked more frequently in addition to the regular inspection.

- The repeated failure of a component has subjected it to especially high stress.

Example: On a crane, the brake lining became worn a second time within a short period due to especially high stress. It must therefore be checked more frequently in addition to the regular inspection.

- The operating conditions were changed and it is not known if these operating conditions place more stress on the crane than before.

Example: The crane is used for a new operation. The load-bearing components of the crane, especially the wire rope, must be checked more frequently in addition to the regular inspection until damage due to the new operating conditions can be ruled out.

- The crane was placed under unusually high stress due to a near-accident.

Example: A load was inadvertently caught with the crane. The load-bearing components of the crane, especially the wire rope, must be checked more frequently in addition to the regular inspection until damage can be ruled out.

The end user is responsible for the inspection of components under especially high stress. The end user also specifies the inspection and test intervals at which the highly stressed components are to be checked. These test intervals can be considerably shorter than the regular inspection.

ABUS Service will gladly provide assistance if needed. See "ABUS Service", page 58.

The end user of the crane is responsible for the proper qualifications of the examiner. For the qualifications, see "Test before initial commissioning", page 35.

GENERAL PLAN



OBSERVE THE PRODUCT MANUALS!

The points listed here are a summary of the section “Check before beginning work and switching on” and the chapter “Inspection” in the other supplied product manuals, and provide only an overview.

In this general plan you will find listed the tests which must be performed on the crane at various intervals.

This general plan is a summary of the information from different chapters and different product manuals.

Information on the tasks to be carried out can be found under the following:

- Tasks which must be done every day (these are primarily functional tests) are usually performed by the crane operator prior to beginning work.

These tasks are therefore listed in all product manuals in the chapter “Operation” in the section “Check before beginning work and switching on”, as well as in the product manual “Operating the ABUS crane”.

- Tasks which are performed in a regular inspection are carried out in accordance with the national regulations by, for example, ABUS Service, the end user’s own maintenance personnel, or specialist service or inspection companies.

These tasks are therefore listed in all product manuals in the section “Inspection”. See “Scope of the inspection”, page 39.

- Lubricant changes which must be performed in a general overhaul, a regular inspection, or in some other deviating interval, are carried out by, for example, ABUS Service, the end user’s own maintenance personnel, or specialist service companies.

These tasks are therefore listed in this and all other product manuals in the section “Lubricants”.

Overhead travelling crane	Jib crane	HB crane	Wire rope hoist	Chain hoist	Push trolley/electric trolley		Daily	Regular inspection
Functional tests								
X	X	X	X	X	X	Are the hoist drive and travel drives functional?	X	X
X	X	X	X	X	X	Are the brakes functional on the hoist drive and travel drives?	X	X
X	X	X	X	X	X	Is the emergency stop button functional?	X	X
			X	X		Is the overload protection functional?		X
			X	X		For hoists without an operating limit switch: Is the top emergency limit switch functional?	X	X
			X	X		For hoists with an operating limit switch: Is the top operating limit switch functional?	X	X
			X	X		For hoists with an operating limit switch: Is the top emergency limit switch functional?		X
			X	X		Is the safety limit switch functional?		X
X	X	X			X	Are the trolley travel and crane travel limit switches functional (braking function / shut-down)?	X	X
X	X	X	X	X	X	If available: Are the warning devices functional?	X	X
X	X	X	X	X	X	Are all other safety devices functional?	X	X
X	X	X				If available: Is the wind anchor functional?		X

Overhead travelling crane	Jib crane	HB crane	Wire rope hoist	Chain hoist	Push trolley/electric trolley		Daily	Regular inspection
Inspection of components								
X	X	X	X	X	X	Can any damage be detected (rust, loose parts, leaking oil, missing screws,...)?	X	X
X	X	X	X	X	X	Can any damage be detected on the supporting structure?		X
X	X	X	X	X	X	Is the crane properly installed and connected?		X
X	X	X	X	X	X	Are all screws tightened and secured?		X
			X	X		Is the load hook rotatable and otherwise OK?	X	X
			X	X		Can any damage be detected on the wire rope or the chain?	X	X
			X			Can any broken wires be detected on the wire rope?	X	X
			X			Can any damage be detected on the mountings of the wire rope (on the cable drum and on the fixed point crosshead) or on the cable guide?		X
			X			Is the rope wedge protrusion correct?		X
X	X	X	X	X	X	Are the required signs present and legible?		X
X	X	X	X		X	Can any damage be detected on the weld seams?		X
X	X	X	X	X	X	Can any damage be detected on the paintwork?		X
			X	X		Is the load hook worn, misshapen or damaged?		X
X	X	X	X		X	Are the gear units of the travel drives and hoist drives sealed?		X
X	X	X	X	X	X	Is the air gap and the brake lining thickness of the brakes on the hoist drives and travel drives correct?		X
X	X	X	X	X	X	Does the crane reach its maximum load capacity?		X
X	X	X	X	X	X	Are all moving parts lubricated?		X
X		X				If applicable: Is the conductor system in order, clean and running smoothly on the current-conducting rails?		X
X		X				If applicable: Are the carbon strips on the current collector still adequate and does the current collector run smoothly?		X
X	X	X	X	X	X	If applicable: Are the rain hoods mounted correctly?		X
X	X	X	X	X	X	Are the panels and other electrical housings dry on the inside, sealed against water penetration and the electrical components free from corrosion?		X
X			X	X		Are the wheel flanges of the wheels worn?		X
X	X	X	X		X	Is the braking distance of the travel drives OK?		X
X			X			If available: Is the diameter of the guide rollers OK?		X
X			X	X		Is the wheel diameter OK?		X
			X	X		Is the bottom block OK?		X
			X			Is the edge protection on the bottom block OK?		X
X	X	X	X		X	Are the safety buffers OK?		X
X	X	X	X	X	X	Is the test log book OK?		X
			X	X		Has the theoretical service life been reached?		X
X	X	X	X	X	X	Do country-specific tests need to be performed?		X

MAINTENANCE

THIS SECTION APPLIES TO ANYONE WHO MAINTAINS, REPAIRS OR MODIFIES THE CRANE.

The end user of the crane is responsible for the selection and proper qualifications of the maintenance personnel.



DANGER TO PERSONS!

Persons can be injured if the crane is incorrectly serviced.

If personnel other than that of the ABUS company are employed to perform maintenance on the crane, it is the end user's responsibility to ensure that these persons are adequately qualified. Follow the procedures described here precisely.

Examples of qualified persons:

- Persons with comprehensive knowledge from specialist training in engineering and in the electrical systems of cranes.
- Persons with sufficient experience in the operation, installation and maintenance of cranes.
- Persons with comprehensive knowledge regarding the relevant technical rules, directives and safety regulations applicable in the respective country.
- Persons receiving regular training from ABUS.

ABUS assumes no liability for damage due to incorrectly performed maintenance work done by unqualified personnel.

ABUS recommends having the maintenance work performed by ABUS Service.

Use only original ABUS replacement parts. Otherwise, all warranty claims will be rendered invalid.

SWITCHING OFF THE CRANE

Before performing any work on the crane:



Switch off the crane.

Otherwise, components of the crane electrical system will be carrying voltage.

It could also happen that another person inadvertently uses the crane, resulting in objects being thrown from the crane or persons falling from the lifting platforms.



DANGER TO PERSONS FROM ELECTRIC SHOCK!

If an emergency stop button has been pressed, there will still be voltage in the panel and in the pendant control. This voltage could injure or kill people.

Completely switch off the crane and secure it against being switched back on before working on it!

If the crane must remain switched on for maintenance work (e.g. changing the wire rope):



Take other measures to ensure that the risk of electric shock is prevented and that other persons do not inadvertently use the crane.

SWITCHING OFF THE CRANE AT THE MAINS SWITCH

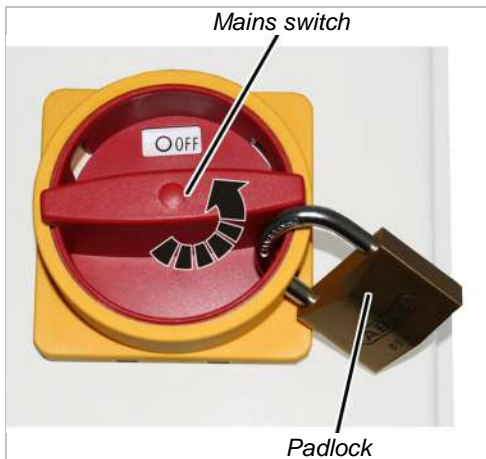

- ➔ Turn the mains switch to 0.
- ➔ Secure with one or more padlocks.

ONLY WITH CRANES WITH CRANE PANELS

This section only applies if the crane has a crane panel (e.g. overhead travelling cranes and, depending on the version and options, possibly also jib cranes and HB cranes).

SWITCHING OFF THE CRANE WITH A MAINS DISCONNECTOR PLUG

This is primarily useful if the entire crane installation cannot be switched off with a general mains switch.

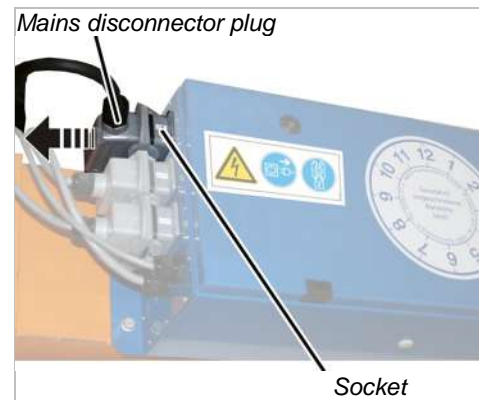

- ➔ Pull the mains disconnecter plug out of the socket on the crane panel.
- ➔ Secure the socket with a padlock to ensure it is not plugged back in accidentally.

Only with chain hoists: The bayonet coupling on the chain hoist cannot be secured against switching back on and is therefore not suitable as a mains disconnecter plug.

INSTRUCTIONS REGARDING SAFETY: PRIOR TO MAINTENANCE

Comply with the following safety instructions before beginning with maintenance:



OBSERVE THE PRODUCT MANUALS!

In addition to the points described here, all information in the section "Instructions regarding safety" in the other supplied product manuals also applies.



DANGER TO PERSONS FROM FALLS!



People can fall when working on the crane.

Falls from great heights can result in people being killed or injured.

Always use suitable lifting platforms and fall protection equipment. If the crane has a walkway on the main girder or on the wire rope hoist, a suitable lifting platform or fall protection equipment must be used for entering the walkway.



DANGER TO PERSONS DUE TO LACK OF BARRIERS!



Falling objects (e.g. tools) can kill or injure people. The lifting platforms can also be overturned, e.g. by forklifts.

Adequately cordon off the operating range.



DANGER TO PERSONS DUE TO OTHER CRANES!



Other cranes can overturn the lifting platforms or impact the crane that is being serviced.

Switch off any other cranes using the same crane track or cranes working above or below. Secure the mains switch so that it cannot be unintentionally switched back on.



DANGER TO PERSONS CAUSED BY MAINTENANCE!

Personnel working in the area may not necessarily be aware of the dangers when maintenance is performed on the crane.

They might be hit by falling tools, or they might mistakenly try to use the crane being serviced.

Notify personnel in the area that maintenance work will be performed.



DANGER TO PERSONS FROM ELECTRIC SHOCK!

Special expertise is required for working on electrical installations.

Without this expertise, there is a risk of electric shock.

Only trained electricians should work on the crane electrical system!

INSTRUCTIONS REGARDING SAFETY: DURING MAINTENANCE

Comply with the following safety instructions during maintenance:



OBSERVE THE PRODUCT MANUALS!

In addition to the points described here, all information in the section “Instructions regarding safety” in the other supplied product manuals also applies.



DANGER TO PERSONS DUE TO REMOVAL OF COVERS!



When covers (e.g. lids of panels, fan covers, motor covers, etc.) are removed, dangerous areas are no longer protected.

As a result of this people can be injured!

Remount covers after working on the crane. Do not permanently remove the covers in order to improve the cooling of components.



DANGER DUE TO BURNING PARTS!



The effects of heat from work performed on the crane (e.g. welding, open flames, flying sparks) can set parts on fire.

This can cause harmful gases to form and parts to become deformed or damaged.

Cover the parts or otherwise protect them from becoming too hot. After completing the work, inspect the condition of the parts.

INSTRUCTIONS REGARDING SAFETY: AFTER MAINTENANCE

Comply with the following safety instructions once maintenance has been completed:



OBSERVE THE PRODUCT MANUALS!

In addition to the points described here, all information in the section "Instructions regarding safety" in the other supplied product manuals also applies.



DANGER TO PERSONS DUE TO LOOSE PARTS!



Loose parts can fall from the crane during operation, killing or injuring people.

Remove tools and separate parts (spare parts, removed parts, etc.).

RELEASING THE CRANE

Release after repair work by the end user:

- ➔ Check whether all work has been fully completed.
- ➔ Check whether the crane is in a secure and operational state.
- ➔ Check whether all separate parts, tools, aids, etc. have been removed.

- ➔ Put the crane into operation.
- ➔ Perform a thorough functional test of the entire crane. See the product manual "Operating the ABUS crane".

SWITCHING TO EMERGENCY CONTROL BY PENDANT CONTROL

ONLY WITH EMERGENCY CONTROL BY MEANS OF THE PENDANT CONTROL WITH ABUS ELECTRICS 3

If a radio remote control fails (e.g. because the batteries for the transmitter have not been charged), the crane can be controlled using a pendant control. The pendant control moves in a mobile control along the main girder independently of the trolley.

For a crane with ABUControl: See the "ABUControl" product manual.

SWITCHING TO EMERGENCY CONTROL

- ➔ Unplug the connection cable for the receiver from the crane control.
- ➔ Unplug the connection cable for the mobile control from the dummy socket and plug into the crane control.
- ➔ Plug the connection cable for the receiver into the dummy socket.
- ➔ Move the pendant control with control cable to the operating range.
- ➔ Plug the control cable of the pendant control into the mobile control.

MODIFYING THE CRANE

ABUS accepts no liability for modifications or changes which were not approved or agreed upon.

The Declaration of Conformity or Declaration of Incorporation issued by ABUS becomes invalid if independent reconstruction or modifications to the crane are performed.

Observe at least these points when making extensive changes to the crane:

- The crane must be able to be switched off by a mains switch or otherwise be isolated from the mains supply at any time.
- The unit must be connected to a protective conductor according to the local and national regulations, the user must be protected from the voltage and the motors protected from overloading.
- An emergency stop device must be available at all times.
- If the hoist motors or travel motors are controlled via frequency converter by a third party, the frequency converter manufacturer's specifications for installation and adjustment must be observed.

To keep voltage peaks from damaging the windings of the hoist motor or travel motor, a general mains filter must be used if the frequency converter is used by a third party.

ABUS recommends using the ABULiner control system, since the frequency converter is optimally matched for the motors used.

ABUS SERVICE

ONLY IN GERMANY

- ➔ If available, have the product number, serial number and customer number handy.
- ➔ Call the ABUS Service Centre:
 - Phone: +49-2261-37-237
- ➔ If calling outside the usual business hours, leave a message on the answering machine.
 - ABUS Service will return your call promptly.
- ➔ If necessary, send a description of the problem by fax or e-mail:
 - Fax: +49-2261-37-265
 - E-mail: service@abus-kransysteme.de

ONLY OUTSIDE GERMANY

- ➔ Call the local ABUS branch or crane service partner.

Your local ABUS branch or crane service partner will provide details of contact data, contacts and availability.

LUBRICANTS



DANGER OF LOADS DROPPING DUE TO LUBRICATED BRAKES!

If the hub on the brake of the hoist motor or travel motor is lubricated, the lubricant can run onto the brake lining and considerably impair the braking. This could cause the load to slip or delay the stopping of the crane.

Do not lubricate the hubs on the brakes!



OBSERVE THE PRODUCT MANUALS!

In addition to the points described here, all information in the section "Lubricants" in the other supplied product manuals also applies.

Note:

Synthetic lubricants may not be mixed with mineral-based lubricants!

CHANGING LUBRICANTS

- ➔ Disassemble the respective components (travel drive, hoist drive,...) and lay them open.
- ➔ Remove the old lubricant at operating temperature.
- ➔ Remove residual lubricant with a suitable cleaning agent.
- ➔ Refill or apply new lubricant.
- ➔ Reassemble the respective components and check that they are sealed.

WIRING DIAGRAMS

- The wiring diagrams of the crane are found in the crane's documentation folder and on the data carrier "ABUDoku".
- For overhead travelling cranes: A copy of the wiring diagrams can also be found in the crane panel.

DECLARATION OF CONFORMITY, DECLARATION OF INCORPORATION

ONLY WITHIN THE EU

DECLARATION OF CONFORMITY

If the crane is sold by ABUS as a stand-alone machine, a Declaration of Conformity is issued. It can be found in the test log book of the crane.

The Declaration of Conformity or Declaration of Incorporation issued by ABUS becomes invalid if independent reconstruction or modifications to the crane are performed.

Konformitätserklärung

Wir, **ABUS Kranssysteme GmbH**, Sonnweg 1, D-51647 Guterbroich

Benötigt für die Zusammenstellung der speziellen technischen Unterlagen: Name, Funktion, Firmenbezeichnung: Daniel Hornbeck

Anschrift: Leitung Technik und Entwicklung, ABUS Kranssysteme GmbH, Sonnweg 1, D-51647 Guterbroich

erklären, dass das Produkt:

Bezeichnung: ABUS
 Tragfähigkeit: 1 t
 Spannweite: 11 m
 Laufkatze: f
 Aufzugsummer: f
 Seriennummer: f

den Bestimmungen der EG-Richtlinien
 2006/42/EG Maschinen
 2006/95/EG Niederspannung
 2004/108/EG Elektromagnetische Verträglichkeit
 in der zum Zeitpunkt der Ausstellung gültigen Fassung entspricht.

Inbesondere wurden folgende harmonisierte Normen
 EN ISO 12100 Sicherheit von Maschinen, Geräten und Anlagen
 EN 60204-1 T32 Elektrische Ausrüstung von Maschinen; Anforderungen für Hebezeuge
 EN 60947-2 Niederspannungsschaltgeräte
 EN 61000-6-4 Elektromagnetische Verträglichkeit; Störaussendung
 EN 61000-6-2 Elektromagnetische Verträglichkeit; Störfestigkeit
 und die nationalen Normen, Richtlinien und Spezifikationen
 DIN 15118 Krane; Grundriss für Stilllegewege
 DIN 15020 Hebezeuge; Grundriss für Seilzüge
 und deren mitgelieferten Normen angewendet.

Eine Technische Dokumentation ist vollständig vorhanden.
 Die zugehörigen Betriebsanleitungen liegen in der Landessprache des Anwenders vor.
 Die Konformitätserklärung erfolgt voraus, dass die Krananlage entsprechend der mitgelieferten Montage-, Betriebs- und Wartungsanleitung montiert und in Betrieb genommen wurde.

Ort, Datum: _____ Unterschrift des Beliebig: _____ Angaben zum Unterzeichner: _____

Der Inhalt dieser Erklärung entspricht EN ISO 17050.
 Die ABUS Kranssysteme GmbH unterhält ein Qualitätsmanagementsystem nach DIN EN ISO 9001:2008.

© ABUS Kranssysteme GmbH, Guterbroich, Version 3 (04/18)

- 1: ABUS company address
- 2: Person responsible for putting together the special technical documentation
- 3: Technical specifications identifying the crane
- 4: Information on the fundamental standards underlying development and production.
- 5: Signature of responsible person

DECLARATION OF INCORPORATION

If the crane is sold by ABUS as a component, in separate components or for installation in another machine, a Declaration of Incorporation is issued in terms of the machinery directive of Appendix II 1B. It can be found in the test log book of the crane.

Putting into service is then prohibited until it has been ascertained that the installation into which the ABUS components are to be installed meet all requirements of the EU directive versions applicable at the time of issuance.

A test must be performed on the ABUS components prior to initial commissioning, before the Declaration of Conformity for the entire installation is issued. See "Test before initial commissioning", page 35.

Einbauerklärung im Sinne der Maschinenrichtlinie Anhang II 1B
 Original-Einbauerklärung

Wir, **ABUS Kranssysteme GmbH**, Sonnweg 1, D-51647 Guterbroich

Benötigt für die Zusammenstellung der speziellen technischen Unterlagen: Name, Funktion, Firmenbezeichnung: Daniel Hornbeck
 Leitung Technik und Entwicklung
 ABUS Kranssysteme GmbH
 Sonnweg 1
 D-51647 Guterbroich

Anschrift: _____

erklären, dass das Produkt:

Bezeichnung: ABUS
 Tragfähigkeit: 1 t
 Spannweite: 11 m
 Laufkatze: f
 Aufzugsummer: f
 Seriennummer: f

den Bestimmungen der EG-Richtlinien
 2006/42/EG Maschinen
 2006/95/EG Niederspannung
 2004/108/EG Elektromagnetische Verträglichkeit
 in der zum Zeitpunkt der Ausstellung gültigen Fassung entspricht.

Inbesondere wurden folgende harmonisierte Normen
 EN ISO 12100 Sicherheit von Maschinen, Geräten und Anlagen
 EN 60204-1 T32 Elektrische Ausrüstung von Maschinen; Anforderungen für Hebezeuge
 EN 60947-2 Niederspannungsschaltgeräte
 EN 61000-6-4 Elektromagnetische Verträglichkeit; Störaussendung
 EN 61000-6-2 Elektromagnetische Verträglichkeit; Störfestigkeit
 und die nationalen Normen, Richtlinien und Spezifikationen
 DIN 15118 Krane; Grundriss für Stilllegewege
 DIN 15020 Hebezeuge; Grundriss für Seilzüge
 und deren mitgelieferten Normen angewendet.

Eine Technische Dokumentation ist vollständig vorhanden.
 Die zugehörigen Betriebsanleitungen liegen in der Landessprache des Anwenders vor.
 Das Inbetriebnehmen und Betreiben der betriebsbereiten Maschine ist solange untersagt, bis die Übereinstimmung der Maschine mit den EG-Richtlinien durch eine Konformitätserklärung bestätigt wird.

Name: _____

Stempelbuch, Nr. 10/2003, Ort, Datum: _____ Unterschrift des Beliebig: _____ Angaben zum Unterzeichner: _____

Der Inhalt dieser Erklärung entspricht EN ISO 17050.
 Die ABUS Kranssysteme GmbH unterhält ein Qualitätsmanagementsystem nach DIN EN ISO 9001:2008.

© ABUS Kranssysteme GmbH, Guterbroich, Version 3 (04/18)

- 1: ABUS company address
- 2: Person responsible for putting together the special technical documentation
- 3: Technical specifications identifying the crane
- 4: Information on the fundamental standards underlying development and production.
- 5: Signature of responsible person

ABUS Kransysteme GmbH
Sonnenweg 1
51647 Gummersbach, Germany
Tel. 0049 – 2261 – 37-0
Fax. 0049 – 2261 – 37-247
info@abus-kransysteme.de

Distribution or reproduction of this document, or the utilisation and disclosure of its contents without explicit approval is prohibited. Violations will result in liability for damages. All rights are reserved in regard to the issuing of patents or registered designs.

AN 120197EN004
2024-08-01

ABUS