



ECH Series Electric Chain Hoists



Eurocrane is committed to exploring intelligent solutions for material handling



Mission:

The world leading company in crane & material handling equipment industry

Values:

Customer First, Teamwork, Full Dedication, Value Creation, Pursuit of Excellence



Stable, reliable, accurate and intelligent Eurocrane basic requirements for each product



Eurocrane, known as hoist expert!
we are an enterprise which is
innovative and pay attention to the
accumulation. In the changing global
market, quality has always been our
persistent competitive advantage:
Having implemented the total quality
control from material to technology,
from the production process to
technical support, Eurocrane has
always been adhering to the spirit
with craftsmen to build our products
and services, improve customer
experience, and create long-term
value for our customers, employees,
and partners.

Through constant improving in efficiency, quality and safety,
Eurocrane all-round class technology brings you more benefits

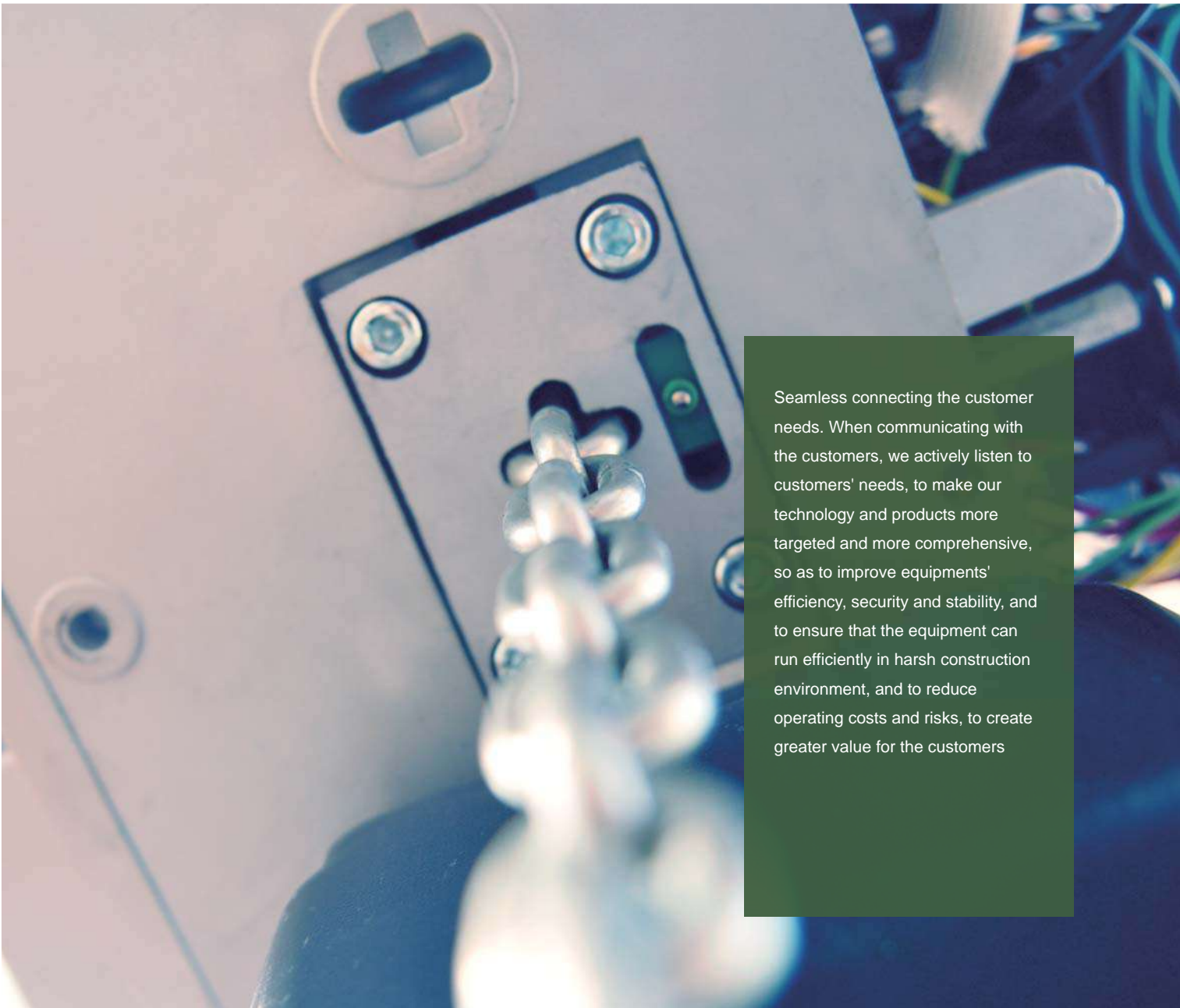

Seamless connecting the customer needs. When communicating with the customers, we actively listen to customers' needs, to make our technology and products more targeted and more comprehensive, so as to improve equipments' efficiency, security and stability, and to ensure that the equipment can run efficiently in harsh construction environment, and to reduce operating costs and risks, to create greater value for the customers

Cutting-edge R&D strength and profound industry experience anticipate and fulfill the customers' requirements

The driving force of Eurocrane's research and development and innovation comes from the business philosophy of "customer first". As the pioneer of hoist industry, we realize that the key to improve customer experience and help the customers achieve permanent success is the anticipation and fulfillment of the customers' requirements: Eurocrane has many years of industry experience on the practical application, which adopts the targeted advanced technologies to provide innovative solutions, and establishes the unique competent advantages for the customers.

Eurocrane uses its innovative research to realize customer satisfaction

Focus on customers' needs, help customers' equipment obtain higher performance and economic returns, and continuously create value for customers



Eurocrane possesses advanced technology, quick reaction mechanism and experienced service team, and has established win-win cooperation relationships with every customer -- we are committed to providing professional service support for your business development.

We, possessing a complete service network and senior engineering and technical teams, can provide 7X24 after-sales support, customized services based on the customers' specific needs, as well as 360 ° service solutions from technical consulting, training, to repair, and maintenance.

Achieve sustainable development



According to the needs of industrial customers and relying on strong research and development and innovation capabilities, Eurocrane has constantly developed the special products with independent intellectual property rights, improved the company's intelligent manufacturing solutions, and provided customers with one-stop industrial services in terms of system upgrading, safety protection, energy saving and efficiency improvement.

In both work and life it is the discipline of all our actions



In the process of enterprise development, Novocrane has accumulated its own set of values. She is the thinking foundation and conduct code of Eurocrane's people, and an important basis for the company to achieve its development vision. We know very well that every accomplishment cannot leave the company staff's professional skills, honesty, commitment and dedication. Moreover, we focus on technology development staff to launch the promotion system of the engineer rank, and have provided specialized talent management skills training for managerial talents, and allows every employee to give full play to their potential in the expertise field, and we are committed to building the career development platform with the openness, inclusiveness and diversity .

Values

Customer First / Teamwork / Full Dedication / Value Creation / Pursuit of Excellence

ECH Electric Chain Hoist

Lifting Capacity: 150Kg-7500Kg



F type

Fixed Electric Chain Hoist

Product Superiority:

- > Brand new contracted design
- > Full-sealed body
- > New-design die-casting aluminum shell
- > Light weight
- > High efficiency transmission
- > Maintenance free
- > Easy operation, light and practical
- > Long service time
- > Safe and reliable



M/E type

Monorail Electric Chain Hoist
Travelling Electric Chain Hoist



P type

Manual Trolley Electric Chain Hoist



Choose according to the need of light and medium duty application.

Tailor Made For Customer

Eurocrane ECH Electric Chain Hoist is compact and reliable. The modular design enables a wide application in complex occasions and customization. Because modularization brings a flexible combination of different lifting capacities, different lifting speeds and working levels, and outstanding performance for quick transportation and precise assembly.

Excellent Performance

The main driving component in hoists of this series is designed to be maintenance free. The electro-magnetic disc brake can reduce the running noise effectively. The standard and humanized design not only improves the operation performance, but also reduces the maintenance cost greatly.

Manufactured In Accordance With International Standard

Eurocrane ECH Electric Chain Hoist is compact, reliable, durable and suitable for a wide range of applications. The hoist of this series has adopted the Germany design concept. ECH Electric Chain Hoists are designed and manufactured fully in accordance with European FEM, EN and Germany DIN standards as well as the ISO and Chinese GB/JB standards.



Dimension

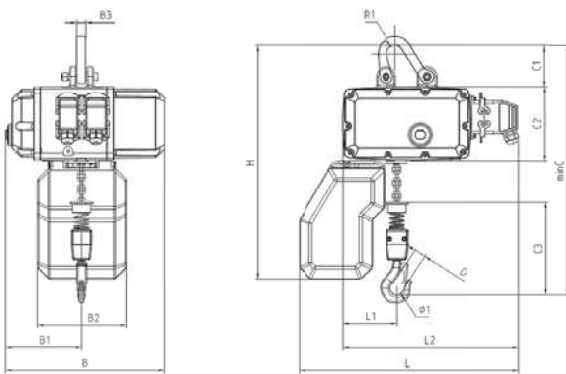

Dimension of ECH1/ECH2-F Types (Fixed)

Model	ECH1051	ECH1051-2	ECH1052	ECH2051	ECH2071	ECH2072
B, mm	348.5	348.5	348.5	381.5	381.5	381.5
B1, mm	166.5	166.5	166.5	185	185	185
B2, mm	195	195	195	195	195	195
B3, mm	20	20	20	24	24	25
H(Size 1), mm	512	512	503	547	547	557
H(Size 2), mm	662	662	653	697	697	707
R1, mm	19	19	23	20	20	27.5
L, mm	478.5	478.5	478.5	526	526	526
L1, mm	115	115	139	118.5	118.5	152
L2, mm	383	383	383	413	413	413
Ø1, mm	30	34	40	34	40	48
D, mm	24	27	32	27	32	38
C, mm	460	475	525.5	505	519	622
C1, mm	91	91	80.5	104	104	114
C2, mm	162	162	162	180.5	180.5	180.5
C3, mm	204	220.5	283	220.5	234.5	327.5

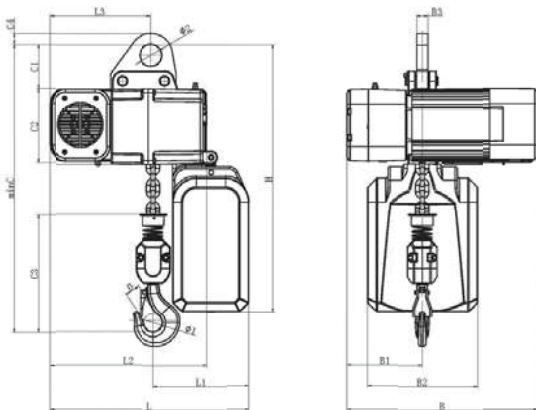

Dimension of ECH5-F Types (Fixed)

Model	ECH5091	ECH5092	ECH5111	ECH5112
B, mm	532	532	532	532
B1, mm	205.5	205.5	205.5	205.5
B2, mm	300	300	300	300
B3, mm	30	30	30	30
H, mm	733.5	733.5	733.5	733.5
Ø2, mm	60	60	60	60
L, mm	549	549	549	549
L1, mm	270	313	267	313
L2, mm	432	432	432	432
L3, mm	278	238	278	238
Ø1, mm	48	50	50	56
D, mm	38	40	40	45
C, mm	643	720	650	754
C1, mm	121	121	121	121
C2, mm	205	205	205	205
C3, mm	316	393	323	427
C4, mm	30	30	30	30



Dimension of ECH1/ECH2-M/E Types (Monorail / Travelling)

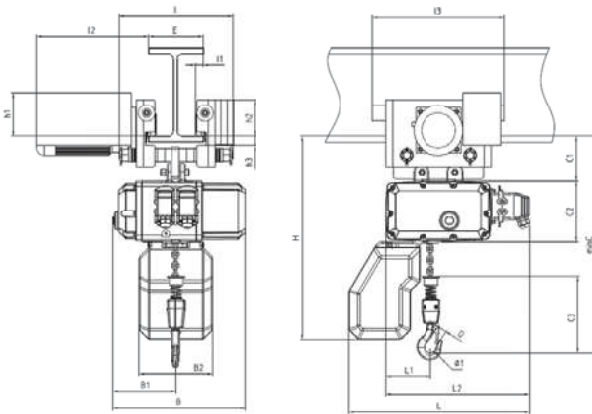

Model	ECH1051-1	ECH1051-2	ECH1052	ECH2051	ECH2071	ECH2072
B, mm	348.5	348.5	348.5	381.5	3381.5	381.5
B1, mm	166.5	166.5	166.5	185	185	185
B2, mm	348.5	348.5	348.5	381.5	381.5	381.5
l, mm	360	360	360	360	360	460
l1, mm	20	20	20	20	20	27
l2, mm	295	295	295	295	295	305
l3, mm	348	348	348	348	348	402
h1, mm	115	115	115	115	115	130
h2, mm	97	97	97	97	97	102
h3, mm	20	20	20	20	20	24
E, mm	50-230	50-230	50-230	50-230	50-230	70-300
H(Size 1), mm	540	540	540	562	562	608
H(Size 2), mm	690	690	690	712	712	758
Ø1, mm	30	40	40	34	40	48
D, mm	24	32	32	27	32	38
L, mm	478.5	478.5	478.5	526	526	526
L1, mm	115	139	139	118.5	118.5	152
L2, mm	383	383	383	413	413	413
C, mm	485	562.5	562.5	521	535	677
C1, mm	117.5	117.5	117.5	120	120	169
C2, mm	162	162	162	180.5	180.5	180.5
C3, mm	204	283	283	220.5	234.5	327.5

Dimension of ECH5-M/E Type (Monorail / Travelling)

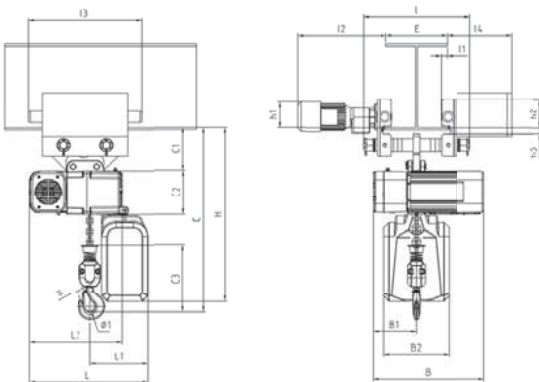

Model	ECH5091	ECH5092	ECH5111	ECH5112
B, mm	532	532	532	532
B1, mm	205.5	205.5	205.5	205.5
B2, mm	300	300	300	300
l, mm	500	500	500	500
l1, mm	27	27	27	27
l2, mm	420	420	420	420
l3, mm	526	526	526	526
h1, mm	119	119	119	119
h2, mm	130	130	130	130
h3, mm	30	30	30	30
E, mm	80-320	80-320	80-320	80-320
H, mm	811	811	811	811
Ø1, mm	48	50	50	56
D, mm	38	40	40	45
L, mm	549	549	549	549
L1, mm	270	313	267	313
L2, mm	431	431	431	431
C, mm	725	800	728	832
C1, mm	199	199	199	199
C2, mm	205	205	205	205
C3, mm	316	393	323	427

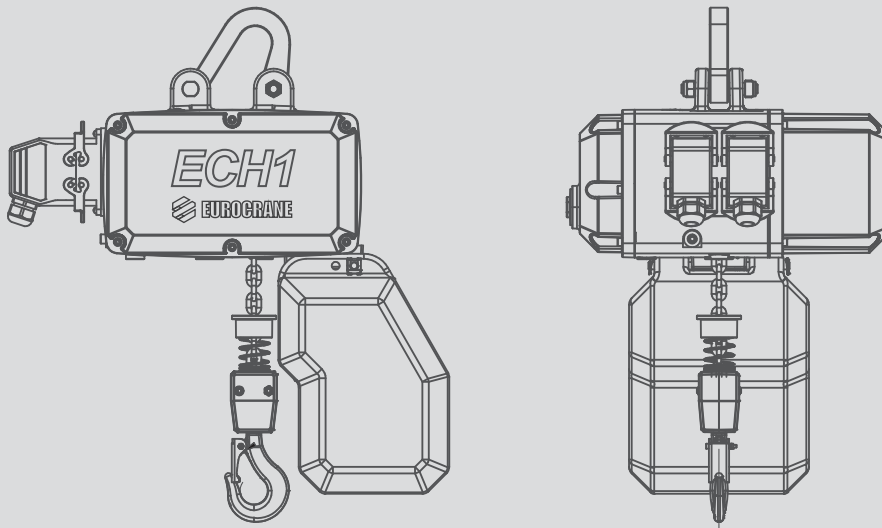

Selection Table of ECH Electric Chain Hoist

Load capacity (Kg)	FEM	ISO	Hoist type	Power (KW)	speed (m/min)	Number of falls
250	3m	M6	ECH105102508	0.75/0.18	8/2	1
250	2m	M5	ECH105102516	0.75/0.18	16/4	1
320	2m	M5	ECH105103208	0.75/0.18	8/2	1
320	1Am	M4	ECH105103216	0.75/0.18	16/4	1
500	1Am	M4	ECH105105008	0.75/0.18	8/2	1
500	3m	M6	ECH207105008	1.9/0.45	8/2	1
500	2m	M5	ECH205105016	1.9/0.45	16/4	1
630	2m	M5	ECH207106308	1.9/0.45	8/2	1
630	1Am	M4	ECH205106316	1.9/0.45	16/4	1
1000	1Am	M4	ECH105210004	0.75/0.18	4/1	2
1000	1Am	M4	ECH207110008	1.9/0.45	8/2	1
1000	2m	M5	ECH509110016	3.5/0.88	16/4	1
1600	2m	M5	ECH207216004	1.9/0.45	4/1	2
1600	2m	M5	ECH509116008	3.5/0.88	8/2	1
2000	1Am	M4	ECH207220004	1.9/0.45	4/1	2
2000	2m	M5	ECH511120006	3.5/0.88	6.3/1.6	1
2000	1Am	M4	ECH511120008	3.5/0.88	8/2	1
2500	2m	M5	ECH509225004	3.5/0.88	4/1	2
2500	1Am	M4	ECH511125006	3.5/0.88	6.3/1.6	1
3200	2m	M5	ECH511232003	3.5/0.88	3.2/0.75	2
3200	1Am	M4	ECH509232004	3.5/0.88	4/1	2
4000	1Am	M4	ECH511240004	3.5/0.88	3.2/0.75	2
4000	2m	M5	ECH511240003	3.5/0.88	4/1	2
5000	1Am	M4	ECH511250003	3.5/0.88	3.2/0.75	2
7500	1Am	M4	ECH511375002	3.5/0.88	2.1/0.5	3

Contact EUROCRANE for more parameters and non-standard products.

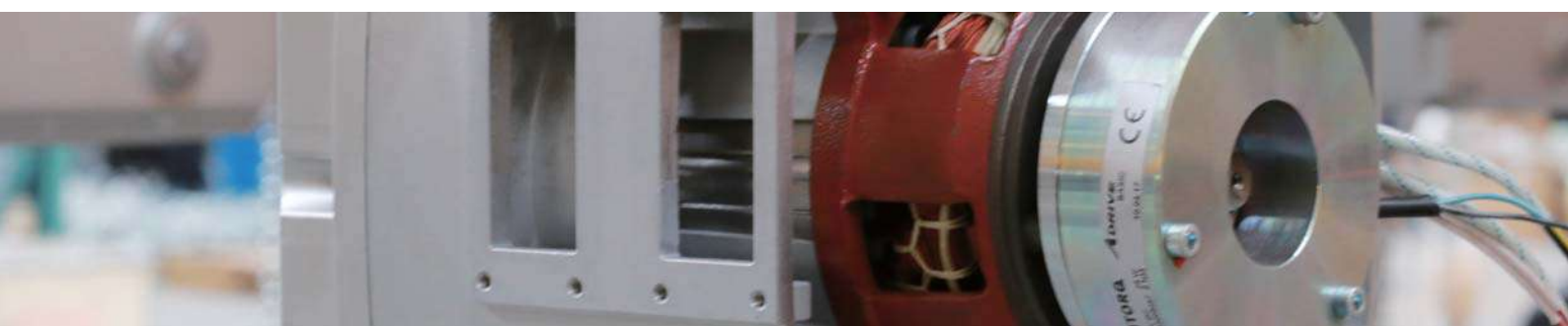
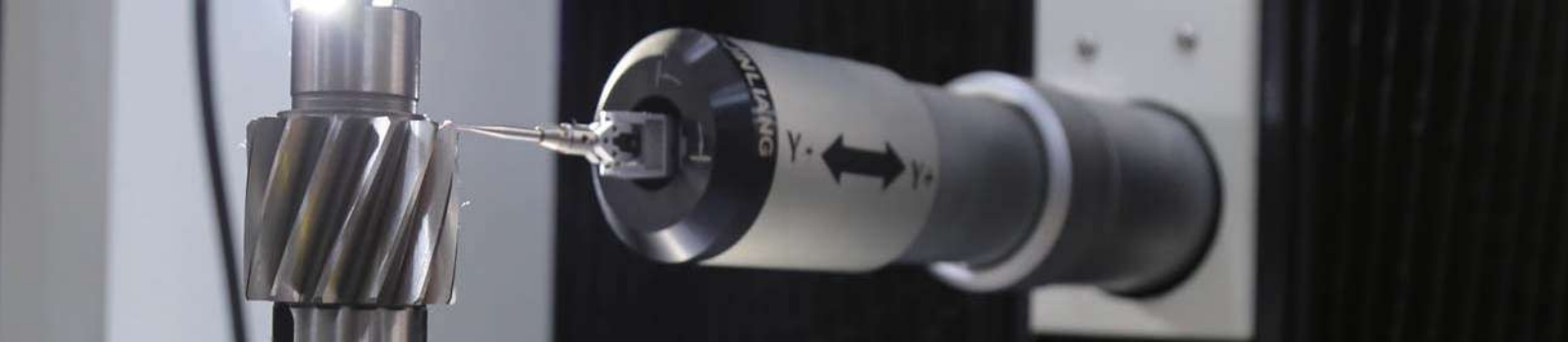

Standard Configuration:

- > Two-speed lifting motor, silver gray body
- > Detachable upper lifting hug
- > Supply voltage: 380V/3P/50Hz
- > Control voltage: 48V
- > Limit switch
- > Black chain box
- > Hook and chain(lifting height :3 m)

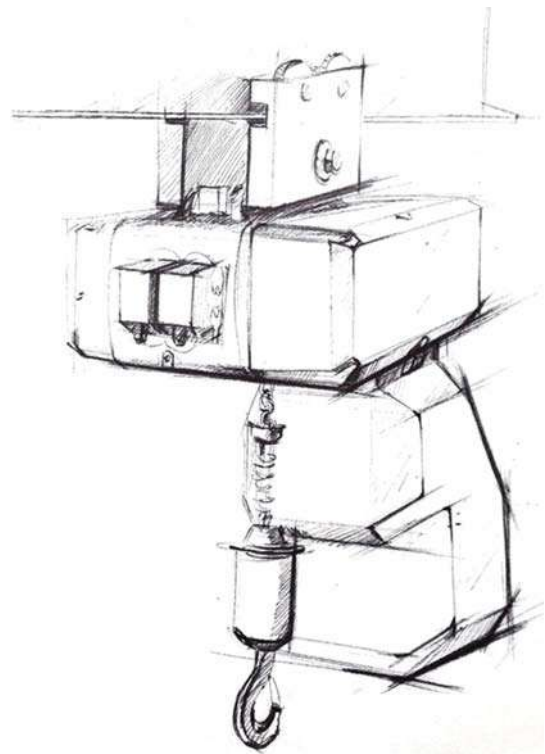





Jib Crane

First choice for material delivery in small area.

The jib crane with Eurocrane ECH electric chain hoist has simple assembly, high price / performance ratio, precise positioning and easy operation. It can reduce the delivery time effectively and improve work efficiency.





Flexible-girder Crane

First choice for material delivery in medium-size spaces.

The flexible-girder crane with Eurocrane ECH electric chain hoist has assembly, light weight and easy maintenance. It provides more configuration options in the layout of work station at late stage.







Rigid-girder Crane

First choice for material delivery in larger area.

The rigid-girder crane with Eurocrane ECH electric chain hoist has strong rigidity, high degree of modularization and small travelling resistance. The various combination can make the delivery more efficient.





Overload Clutch

Integrated on the drive gear shaft
 Overload protection function: keep torque safe.
 Up to 1.4 times of safe load capacity
 Maintenance-free design, adjustable overload torque



Reduction Gearbox

Helical-gear design, high transmission efficiency, low noise
 Process with hardened gear, heat treatments after grinding, accuracy grade of gear: 6
 Full oil bath lubrication, ultra-low noise and ultra-long life
 Perfect meshing and efficient transmission



Brake

Electromagnetic disc brake is arranged at the end of the drive gear shaft
 Asbestos free
 Maintenance-free design, service life: 1 million brakes
 Fully enclosed, high protection grade
 Suitable for severe conditions

COMPONENT

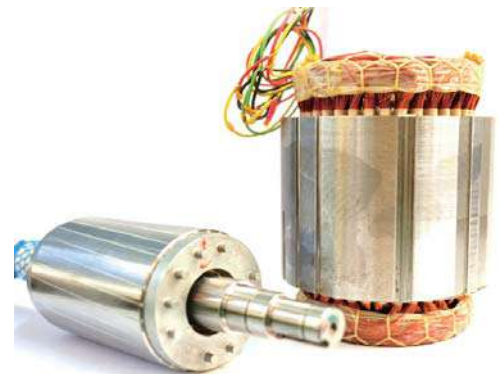
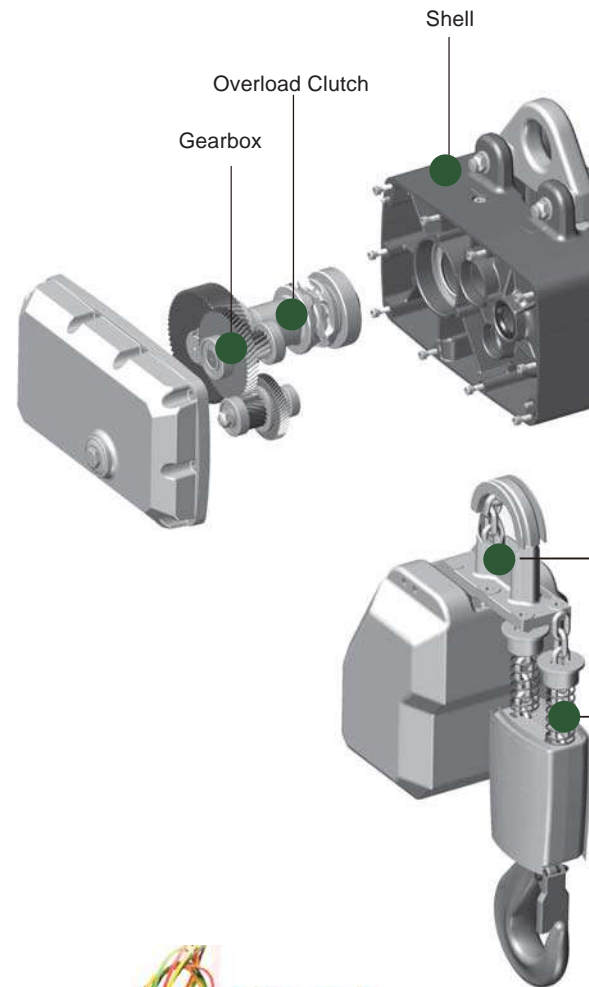

Lifting Motor

Light weight, small in size, rotation speed: up to 3000 rpm
 High starting torque, high superior performance
 Motor load: 60%, suitable for high-frequency lifting
 Protection grade: IP55, insulation grade: Class F

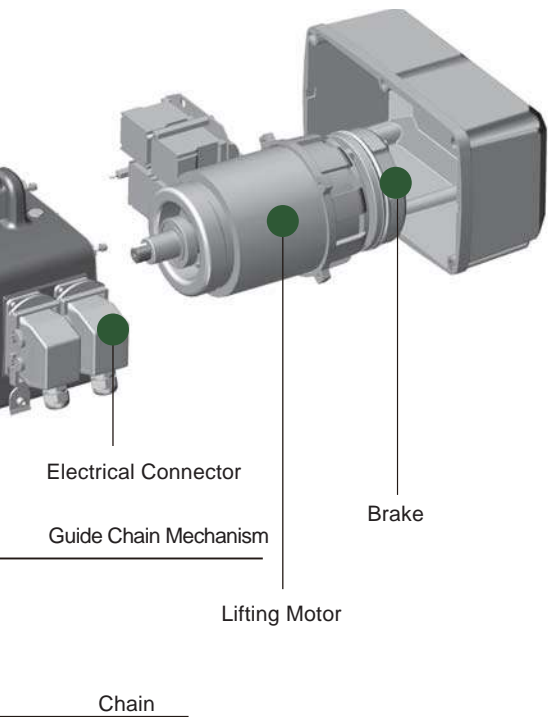

Shell

- High strength alloy die-casting and moulding in one
- Good corrosion resistance and air-tightness
- Special suspension design
- Keeps the box body from the lifting load
- Material of electric shell: engineering plastic
- Light weight and good heat dissipation



Electrical Connector

- Standard Aluminum connectors
- Mis-connection proof and leakage proof
- Ten core connector, easy control and power supply
- Plug and play, convenient and efficient



Guide Chain Mechanism

- Five-socket guide chain wheel
- Hardening treatment on surface
- Smoother and quieter
- Suitable for aggressive working environment



Chain

- Special high-strength alloy steel carburized chain
- Zinc coating on surface
- Wear resistance and corrosion resistance
- High safety coefficient



We are committed to providing industry cutting-edge products and technology



Eurocrane (China) Co., Ltd.

Add: No. No.288-388, Fen Yue Road, Foho New & Hi-Tech Industrial Development Zone, Suzhou, Jiangsu, China (215211)

Tel: 86-512-8207 2666#8079 Fax: + 86-512-8207 2999

Email: contact@eurocrane.com.cn Website: www.eurocraneglobal.com

Eurocrane retain the right of changing the product's design and specifications any time; when procurement and delivery, please refer to the actual product.