



EWH Series Wire Rope Electric Hoists



Eurocrane is committed to exploring intelligent solutions for material handling



Mission:

The world leading company in crane & material handling equipment industry

Values:

Customer First, Teamwork, Full Dedication, Value Creation, Pursuit of Excellence



Stable, reliable, accurate and intelligent Eurocrane basic requirements for each product



Eurocrane, known as hoist expert!
we are an enterprise which is
innovative and pay attention to the
accumulation. In the changing global
market, quality has always been our
persistent competitive advantage:
Having implemented the total quality
control from material to technology,
from the production process to
technical support, Eurocrane has
always been adhering to the spirit
with craftsmen to build our products
and services, improve customer
experience, and create long-term
value for our customers, employees,
and partners.

Through constant improving in efficiency, quality and safety,
Eurocrane all-round class technology brings you more benefits



Seamless connecting the customer needs. When communicating with the customers, we actively listen to customers' needs, to make our technology and products more targeted and more comprehensive, so as to improve equipments' efficiency, security and stability, and to ensure that the equipment can run efficiently in harsh construction environment, and to reduce operating costs and risks, to create greater value for the customers

Cutting-edge R&D strength and profound industry experience anticipate and fulfill the customers' requirements

The driving force of Eurocrane's research and development and innovation comes from the business philosophy of "customer first". As the pioneer of hoist industry, we realize that the key to improve customer experience and help the customers achieve permanent success is the anticipation and fulfillment of the customers' requirements: Eurocrane has many years of industry experience on the practical application, which adopts the targeted advanced technologies to provide innovative solutions, and establishes the unique competent advantages for the customers. Eurocrane uses its innovative research to realize customer satisfaction

Focus on customers' needs, help customers' equipment obtain higher performance and economic returns, and continuously create value for customers

Eurocrane possesses advanced technology, quick reaction mechanism and experienced service team, and has established win-win cooperation relationships with every customer -- we are committed to providing professional service support for your business development. We, possessing a complete service network and senior engineering and technical teams, can provide 7X24 after-sales support, customized services based on the customers' specific needs, as well as 360 ° service solutions from technical consulting, training, to repair, and maintenance.



Achieve sustainable development

According to the needs of industrial customers and relying on strong research and development and innovation capabilities, Eurocrane has constantly developed the special products with independent intellectual property rights, improved the company's intelligent manufacturing solutions, and provided customers with one-stop industrial services in terms of system upgrading, safety protection, energy saving and efficiency improvement.



In both work and life it is the discipline of all our actions

In the process of enterprise development, Novocrane has accumulated its own set of values. She is the thinking foundation and conduct code of Eurocrane's people, and an important basis for the company to achieve its development vision. We know very well that every accomplishment cannot leave the company staff's professional skills, honesty, commitment and dedication. Moreover, we focus on technology development staff to launch the promotion system of the engineer rank, and have provided specialized talent management skills training for managerial talents, and allows every employee to give full play to their potential in the expertise field, and we are committed to building the career development platform with the openness, inclusiveness and diversity .

Values

Customer First / Teamwork / Full Dedication / Value Creation / Pursuit of Excellence



Efficient Intelligent equipment based on customer requirements

EWH Serial Electric Wire-Rope Hoist

Load Capacity: 3.2t-80t

Product Advantages:

- > Innovation based on rich experience
- > Compact structure guarantees energy conservation
- > High-efficient transmission system
- > Excellent performance with safety and reliability



▲
Double Girder Electric Hoist



▲
Single Girder Electric Hoist



▲
Double Girder Double Hook Electric Hoist



Compact structure, light weight, and small wheel load ,low operation cost, environmental and energy saving

The leading technique and excellent performance can bring us an optimized overall dimension. EWH electric wire rope hoist increased the hook working area with its compact design .Increased the utilization of limited factory space. Crane system with EWH electric hoist can effectively reduce the weight of the equipment to reduce power consumption, and the operating noise is lower than the requirement of international standard. Hence it is known as an equipment with comfort of operation, economical cost, and low energy consumption.

High-quality components, modular design, safe, reliable and durable

The 3-in-1 lifting mechanism specially designed for EWH series electric hoists has compact structure and excellent performance. The deceleration gear with high precision grinding and tooth surface hardening treatment is durable and low noise.

60% ED for lifting motor meeting the production requirement of high frequency use, also improves the product reliability. The imported brake disc has excellent wear resistance of which service braking life is up to more than 1 million times.

Precise positioning, efficient running and high production efficiency

Standard double speed lifting(variable frequency is optional) and frequency conversion control for crane trolley brings an efficient operation of the crane. This greatly improves the logistics efficiency of the workshop, and can assure the accomplishment of work plans on time.

The application of frequency conversion technology can effectively reduce the shaking during load lifting for fast and precision positioning. It can also obviously reduce the impact in the starting and braking process. The lifting will become more stable and safe.

Intelligent control system, humanized design, convenient operation

The patented control system EUROSTAR and the man-machine friendly interface design can record and monitor the operation status of electric hoists, operation condition of the motor and the safety work period. It also has a warning function. The operation record provides a data basis for a timely and accurate maintenance.



FEM



Customized Design

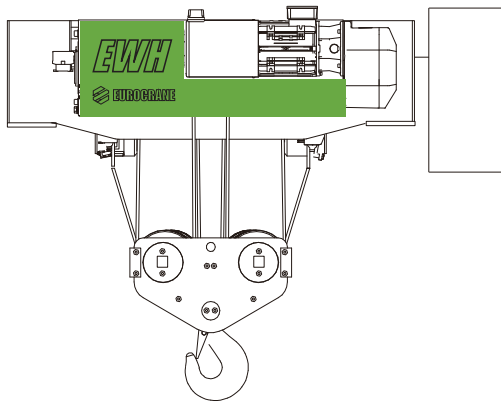

Fixed TYPE

The hoists are not equipped with a trolley and used for applications where horizontal movement is not required.

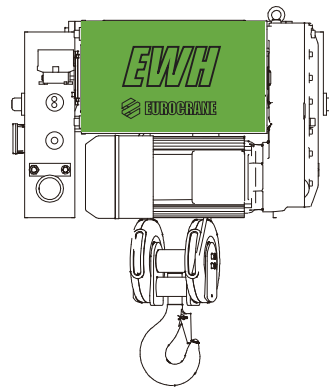

Low Headroom Trolley TYPE

These hoists are fitted with a trolley for loads and are designed to make optimal use of the height of lift and the limited space available.

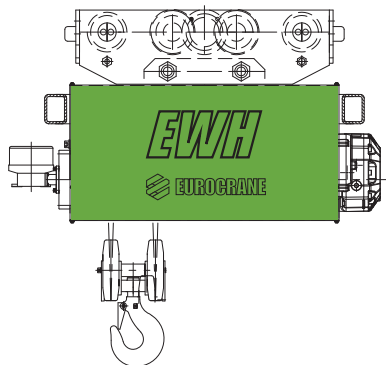

Normal Headroom trolley TYPE

These hoists are fitted with a trolley and used for applications where horizontal movement is required.

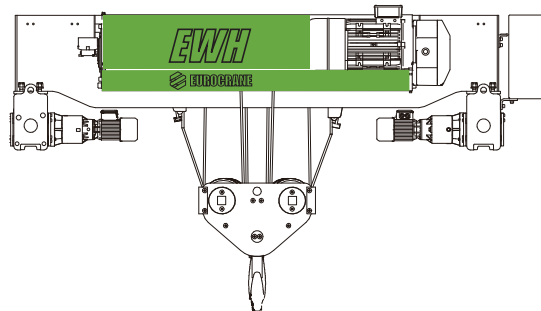

Double Girder trolley TYPE

These hoists are fitted with a trolley for horizontal movement of loads and are designed to move particularly heavy loads.

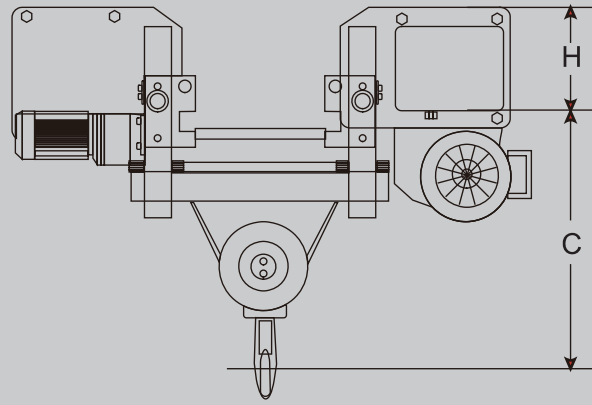
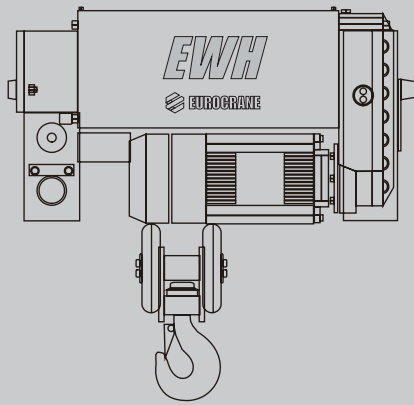

EWH Wire Rope Hoist Dimension Table for Single Girder Crane

Load Capacity (Kg)	FEM	ISO	Height (m)	Speed (m/min)	Trolley Speed (m/min)	H Size (mm)	C Size (mm)
1000	4m	M7	6/9/12	0.8/5.0	5~20	232	500
1250	3m	M6	6/9/12	0.8/5.0	5~20	232	500
1600	3m	M6	6/9/12	0.8/5.0	5~20	232	500
1600	2m	M5	6/9/12/18	1.6/10.0	5~20	254	660
2000	2m	M5	6/9/12	0.8/5.0	5~20	232	500
2000	3m	M6	6/9/12/18	1.6/10.0	5~20	254	660
2500	3m	M6	6/9/12	0.8/5.0	5~20	232	500
2500	2m	M5	6/9/12/18	1.6/10.0	5~20	254	660
3200	2m	M5	6/9/12	0.8/5.0	5~20	232	500
3200	1Am	M4	6/9/12/18	1.6/10.0	5~20	254	660
5000	2m	M5	6/9/12/18	0.8/5.0	5~20	254	590
5000	2m	M5	6/9/12/18	1.6/10	5~20	321	790
6300	1Am	M4	6/9/12/18	0.8/5.0	5~20	254	590
8000	3m	M6	6/9/12/18	0.8/5.0	5~20	321	740
10000	2m	M5	6/9/12/18	0.8/5.0	5~20	321	740
10000	3m	M6	6/9/12/18	0.6/4.0	5~20	364	850
12500	1Am	M4	6/9/12/18	0.8/5.0	5~20	321	740
12500	2m	M5	6/9/12/18	0.6/4.0	5~20	404	850
16000	2m	M5	6/9/12/18	0.6/4.0	5~20	404	850
20000	1Am	M4	6/9/12/18	0.6/4.0	5~20	404	850

For more options, please contact EUROCRANE

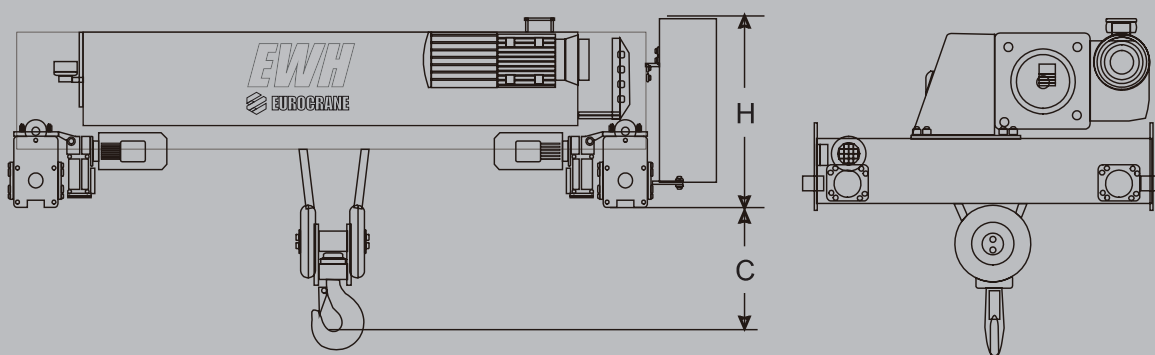

EWH Wire Rope Hoist Dimension Table for Double Girder Crane

Load capacity (Kg)	FEM	ISO	Height (m)	Speed (m/min)	Trolley Speed (m/min)	H Size (mm)	C Size (mm)
2000	3m	M6	6/9/12	0.8/5.0	5~20	471	390
3200	2m	M5	6/9/12	0.8/5.0	5~20	471	390
5000	2m	M5	6/9/12/18	0.8/5.0	5~20	471	450
6300	1Am	M4	6/9/12/18	0.8/5.0	5~20	471	450
8000	3m	M6	6/9/12/18	0.8/5.0	5~20	542	650
10000	2m	M5	6/9/12/18	0.8/5.0	5~20	542	650
10000	3m	M6	6/9/12/18	0.6/4.0	5~20	679	700
12500	1Am	M4	6/9/12/18	0.8/5.0	5~20	542	650
12500	2m	M5	6/9/12/18	0.6/4.0	5~20	679	700
16000	2m	M5	6/9/12/18	0.6/4.0	5~20	679	700
20000	1Am	M4	6/9/12/18	0.66/4.0	5~20	679	700
20000	2m	M5	6/9/12/18	0.53/3.4	5~20	850	1200
25000	1Am	M4	6/9/12/18	0.53/3.4	5~20	850	1200
25000	2m	M5	6/9/12/18	0.8/3.3	5~20	864	1000
32000	2m	M5	6/9/12/18	0.8/3.3	5~20	864	1000
32000	2m	M5	6/9/12/18	0~4.9	5~20	1025	950
40000	1Am	M4	6/9/12/18	0~4.9	5~20	1025	950
50000	2m	M5	6/9/12/18	0~3.2	5~20	1023	1150
63000	1Am	M4	6/9/12/18	0~3.2	5~20	1023	1150
80000	1Bm	M3	6/9/12	0~2.4	5~20	1080	1500

For more options, please contact EUROCRANE

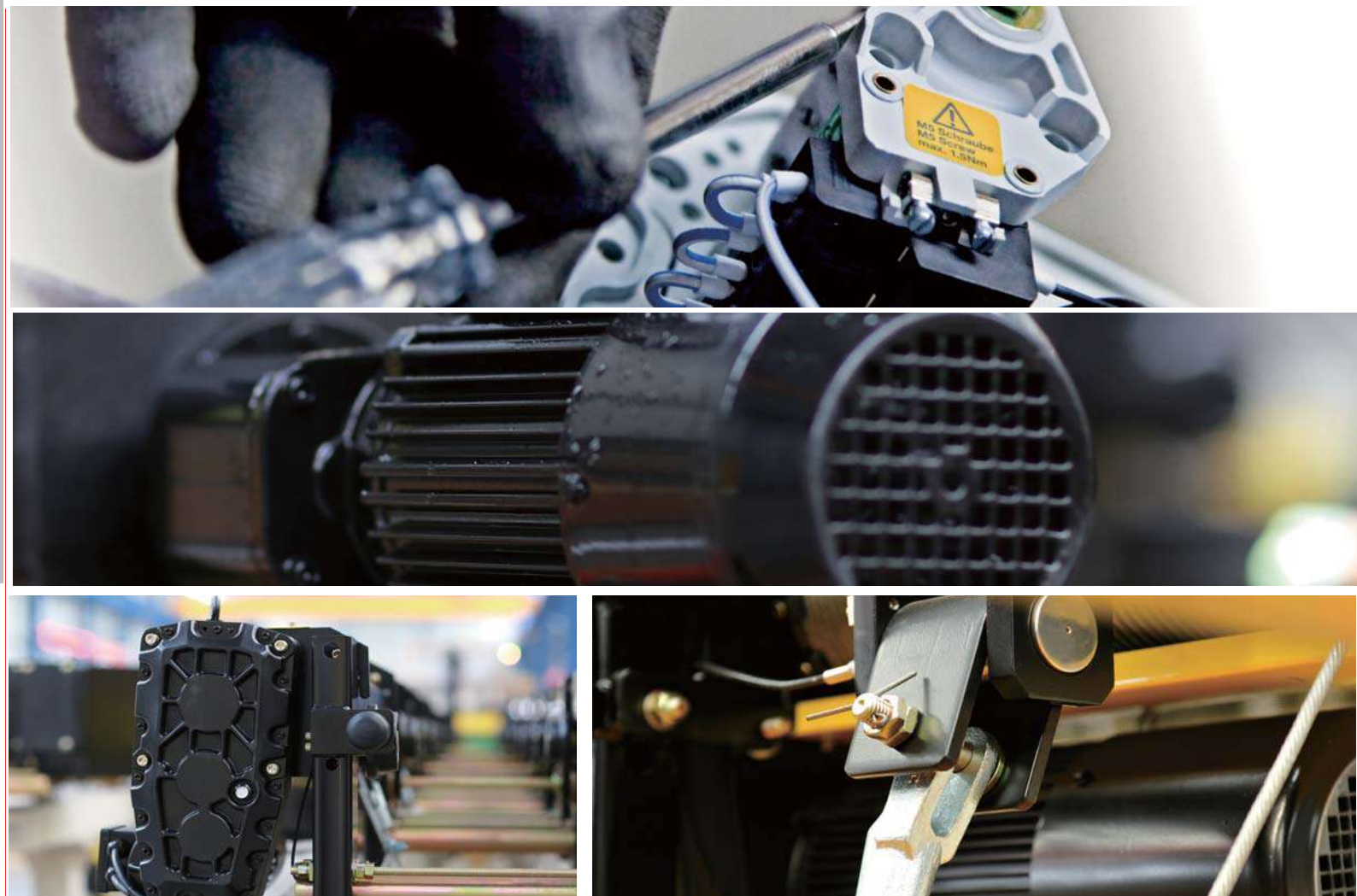

Standard Configuration:

- Double-speed lifting motor for 1t~32t hoists; lifting motor with variable frequency for 32t~80t hoists
- Electromagnetic disc brake, maintenance-free design
- Supply voltage: 380V/3Ph/50Hz
- Control voltage: 48V
- Lifting limit switch
- Trolley is equipped with variable frequency motor, speed: 5~20m/min
- Protection grade of motor: IP55, insulation grade: F
- Hook set with safety buckles
- Load lifting limiter
- Ambient temperature: -20 °C ~ 40 °C

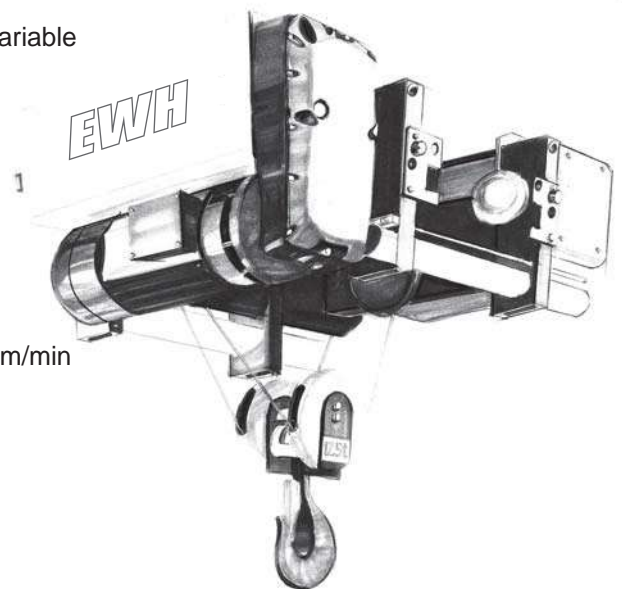



EWHEX Explosion-proof Electric Hoist

Load Capacity: 3.2t-20t

Eurocrane develops series of explosion-proof electric hoists to meet the special requirements of food industry, chemical industry, petroleum and natural gas industries. This provides guarantee for safety production and efficiency improvement.

Products meet international standards. With reliable performance and can bring safety production for customers.

Product Advantages:

- Keep to international standards, safe, reliable and efficient
- Intelligent design, precise positioning and high working frequency
- Ergonomic design, comfortable & convenient operation
- Maintenance free / easy maintenance design, convenient maintenance
- Pass through rigorous test, long service life

International Standards:

- Machinery Directive 2006/42/EC
- ATEX Directive 2014/34/EU
- EMC, Directive 2004/108/EC
- EN13463-1:2009
- EN13463-5:2011
- EN60079-0:2012+A11:2013
- EN80079-36:2016
- EN80079-37:2016

Explosion Proof Grade

- Gas explosion proof: II 3 G c II C T 4
- Dust explosion proof: II 2 D h III C T135 °C

Explosion-proof Area:

- Gas explosion proof: area 2;
- Dust explosion protection: area 21 and 22;
- Ambient temperature: -20 °C ~ 40 °C.



EDR Clean Room Electric Hoist

Load Capacity: 0.25t-20t

Taking safety, cleanliness, compact and reliability as the target, Eurocrane has developed EDR electric hoists, which are suitable for clean space, to meet the hygiene requirements of special workshop in precision electronics, aviation, biotechnology, medical apparatus and instruments, pharmaceutical production, food production, semiconductor manufacturing industries. Various types of wire rope hoists, chain hoists and crawler hoists have a lifting capacity range from 0.25t to 20t, and can be used in environment of hygiene grade 1000.

Clean Room Electric Hoist Application Standard

The dividing standard is established by larger than or equal to the maximum concentration limit of considered particle in the unit volume of clean room. Air cleanliness: the degree of dust content in clean air (that is, dust content). High dust concentration means low cleanliness, and low dust concentration means high cleanliness.

Chinese Standard GB50073-2001 (International Standard ISO14644-1)

Cleanliness Class (N)	Larger than or equal to the maximum concentration limit of particles (pc/m ³)					
	0.1µm	0.2µm	0.3µm	0.5µm	1µm	5µm
ISO1	10	2				
ISO2	100	24	10	4		
ISO3	1000	237	102	35	8	
ISO4	10000	2370	1020	352	83	
ISO5	100000	23700	10200	3520	832	29
ISO6	1000000	237000	102000	35200	8320	293
ISO7				352000	83200	2930
ISO8				3520000	832000	29300
ISO9				35200000	8320000	293000

Eurocrane clean room products meet standard ISO3 and below





Corrosion-Proof Electrical Hoist

Load capacity: 12.5t

Product Data :

Load: 12.5 t
Hoisting Height: 12 m
Hoisting Speed: 1.2/5 m/min
Travelling Speed: 20 m/min
Operation Group: 2m(M5)
Power Supply: AC380V 50HZ

Product Advantages:

Acid & Alkali Resistant, Anti-Oxidative
High Protection Rating

- Surface is special anti-corrosion treated for acid and oxidation resistance, which brings outstanding corrosion-proof character
- Upgrade protection level by IP56 as standard
- Key components are isolated to protect the machine body effectively

Apply in Marine Chemistry, Metal Processing, Petrochemical Engineering

***Under Any Circumstance
We Promise Safety***



A large industrial scene showing molten metal being poured into a ladle in a metallurgy plant. The environment is filled with bright orange and red light from the molten metal.

Metallurgy Electrical Hoist

Load capacity: 5t

Product Data :

Load: 5 t

Hoisting Height: 6 m

Hoisting Speed: 1.3/8 m/min

Travelling Speed: 20 m/min

Operation Group: 3m(M6)

Power Supply: AC380V 50HZ

Product Advantages:

Safety, Efficiency, High Temperature Resistance
Double-Brake and Anti-Swing Design

- Anti-swing design is adopted to reduce the risk of splashing molten metal load and improve stability.
- Optimization of heat insulation: isolation panels are equipped on key parts, which can prevent hazards from thermal radiation to machines
- Optimization of safety: double-brake design for hoisting can maintain the load even when the working brake can not run properly
- Mechanical redundancy design can maintain the load when one of the ropes is broken.

Apply in Mine Industry, Metallurgy Casting (Iron, Steel, Aluminium), etc.

Best Choice of Metallurgy Fields





Mould Lifting Electrical Hoist

Load capacity: 10/3.2t

Product Data :

Load: 10/3.2t
Hoisting Height: 9 m
Hoisting Speed: 0.8/5 -1.6/10m/min
Travelling Speed: 20 m/min
Operation Group: 2m (M5)
Power Supply: AC380V 50HZ

Product Advantages:

Stability , Safety , High Level of Classification Grade

- Anti-swing design is adopted to improve the efficiency of mould-matching & operation stability;
- Cycloidal hook design can protect the wire rope and optimize flipping performance;
- High level of operation group meets the demand of high-duty application;

Apply in Automobile Manufacture, Construction Machinery, Mould Casting, etc.

Details Determine Quality





Eurocrane Product & Service Center has a countrywide service network operated by the passionate, professional and experienced technical support teams who have access to the quick and sufficient spare parts supply. Fully complied with QA/QC system and national safety standards, we standardized our service in the way of "Safe, Professional and Prompt", and we strive for providing the complete solution and creating sustainable value for our customers.

Emergency Services :

Lifting equipment is crucial for maintaining transportation and logistics. The production can be adversely impacted while the unscheduled loss can be significant due to the downtime caused by the failures of lifting equipment. In these cases, please contact our service center ASAP. Our mobile service professionals shall come to your site with necessary repairing kits and spares to help for a timely recovery.

We promise your priority and we concern your concerns. Eurocrane has already established a well located national service network in the major districts. Our service center will instantly respond to your request and the service professionals and engineers at the nearest availability shall be dispatched to your site for assistance of trouble shooting and restoration.

Spare Parts :

The spare parts provided by Eurocrane are guaranteed with safe and reliable operation. The sufficient stock holdings at the warehouse in Suzhou headquarter ensures a timely supply to meet your spare requirements.

Maintenance :

Often than not, some users are used to seeking for assistance once and only at the emergency of breakdown failures, which would have caused significant down time and unscheduled loss cost due to the adversely impacted production and delivery schedule. The routine predictive and preventive maintenance will ensure the availability of your equipment, minimize the failure occurrence and reduce the unscheduled losses hence an achievable cost reduction with the extended service life Will improve equipment utilization. In the most cases, PM maintenance regime is the key factor for the optimal reduction of operational cost.

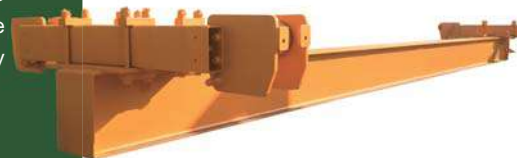
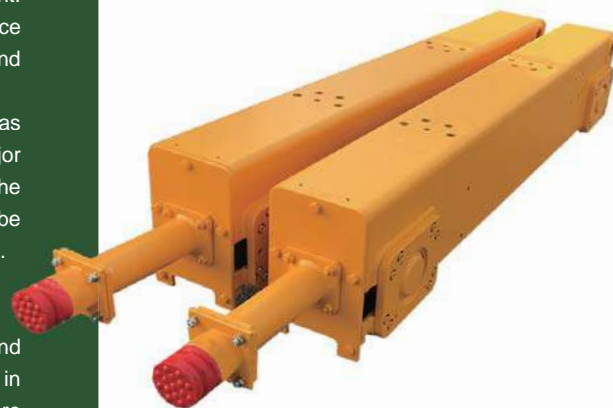



Drum

Use seamless steel tube as raw material and process it by numbers of working procedure.

Advanced processing methods to ensure concentricity of the drum. The depth of rope groove is in compliance with the FEM standard. High-strength pressing plates and bolts are fastened on the end of the wire rope to ensure the safety of lifting.



Electrical System

The easy-to-service control system has the multiple safety protection devices to ensure equipment safe. IP54 protective grade. Quick connector reduces installation and maintenance work to minimum.

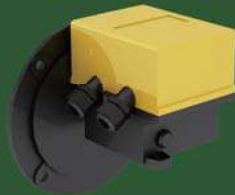

Lifting Gear Limit Switch

The limit switch with 4 cams can be accessed on the gear unit and is used for managing the upper and lower limit switches of the hook, switching from low to high speed, and for managing phase reversals.

COMPONENT

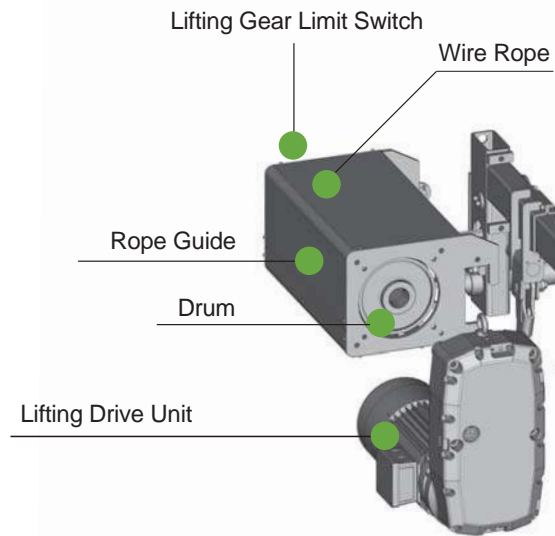

Trolley Drive Unit

Motors include F class insulation and IP55 degree of protection as standard with a special inverter insulation. This motor's ED is 40%.

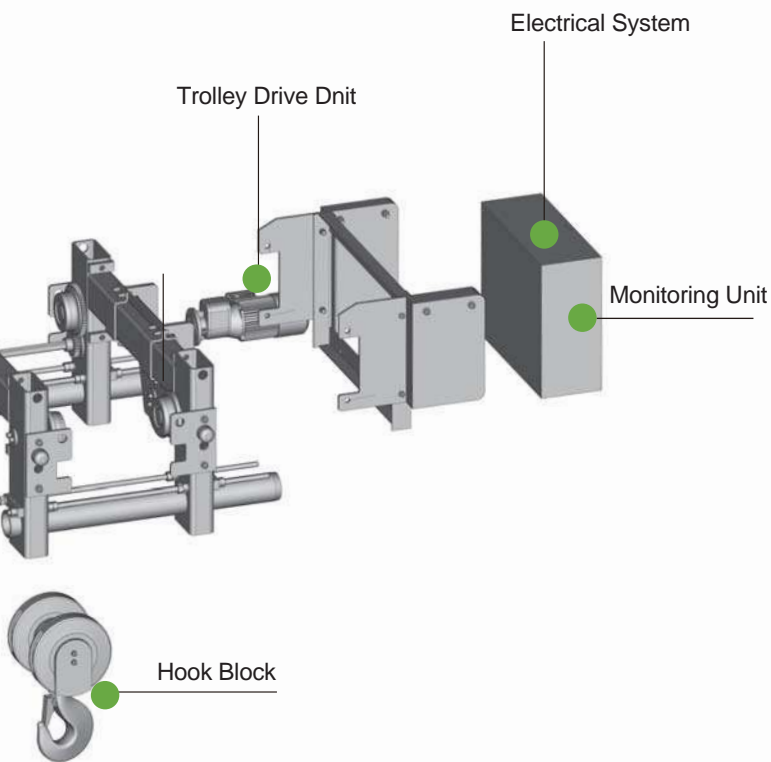

Lifting Drive Unit

Double winding asynchronous motors, aluminum round frame
 60 % duty factor and tropicalized as a standard for greater longevity.
 IP55 protection, F class Insulation, B class heating, with over temperature protection
 Electromagnetic brake, maintenance free
 In normal use the brake lining has been designed for the hoist life.
 Easy access to the air-gap measuring
 The hoisting gearbox comprises multistage gear transmission.
 Lightweight gear units with silent running and hard tooth-surface gears deliver the torque required



Rope Guide

Light weight
 Good wear resistance
 Prevent wire rope from skipping and loosing to off-groove



Wire Rope

Wire rope of high-performance with tensile strength up to 2160MPa.
 The surface with galvanized processing for corrosion prevention effectively.
 With good flexibility to ensure wear resistance of the wire rope and prolong its service life.



Hook Block

Concise and sturdy hook block has the outstanding features of DIN standard: protective hook shield, machined pulley and high-strength material of T-grade load hook.



Monitoring Unit

The electrical cubicle on the hoist may contain the condition monitoring unit that supervises the safe operation of the hoist. The unit collects data on functions that affects safety and calculates the remaining time in the Safe Working Period (SWP) during which the hoist can operate safely. It has the practical and friendly human-machine interface and easy operation



We are committed to providing industry cutting-edge products and technology



Eurocrane (China) Co., Ltd.

Add: No. No.288-388, Fen Yue Road, Foho New & Hi-Tech Industrial Development Zone, Suzhou, Jiangsu, China (215211)

Tel: 86-512-8207 2666#8079 Fax: + 86-512-8207 2999

Email: sw2@eurocrane.com.cn Website: www.eurocraneglobal.com

Eurocrane retain the right of changing the product's design and specifications any time; when procurement and delivery, please refer to the actual product.